



Dieses Modell ist mit Scaleteilen ausgestattet



Ord.No. 11/60
Rohrschneider
für Rohre bis ϕ 15 mm
auch zum Bördeln geeignet



Ord.No. 11/31
Schneidezange für Stahldraht



Ord.No. 11/26
Scheibenschere



Ord.No. 11/59
Schneidewerkzeug:
Skalpell & Stahllineal
Ord.No. 11/58
Skalpell



Ord.No. 90/10
Feilen-Set mit Griff
6-teilig



Ord.No. 11/28
Schmirgelfeile 25 cm, gerade
Ord.No. 11/56
Schmirgelfeile 25 cm, konvex/konkav
Ord.No. 11/57
Schleifband
Rollenlänge 60 cm

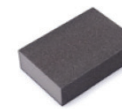

Ord.No. 10/77
Schleifschwamm



Ord.No. 10/76
Schleifgrundierung



Ord.No. 11/29
Widia-Trennscheibe
inkl. Aufspanndorn



Ord.No. 11/36
Trennscheiben-Satz
5 Stück



PERMA-GRIT
Ord.No. 90/57
Trennscheibe ϕ 19 mm
Ord.No. 90/56
Trennscheibe ϕ 32 mm
jeweils inkl. Aufspanndorn



PERMA-GRIT
Ord.No. 90/54
Rundfeile ϕ 4 mm fein
Ord.No. 90/55
Schleifstift Dom ϕ 7 mm

PERMA-GRIT



Ord.No. 90/51
Handfeile viereckig ϕ 6 mm
Ord.No. 90/49
Handfeile rund ϕ 6 mm
Ord.No. 90/50
Handfeile halbrund



Ord.No. 90/47
Handfeile flach
Ord.No. 90/52
Handfeile viereckig
Ord.No. 90/48
Handfeile rund ϕ 12 mm



Ord.No. 90/53
Schleifklotz abgeschrägt



Ord.No. 90/40
Nadelfeilen-Set, bestehend aus:
Ord.No. 90/46 Handgriff
Ord.No. 90/41 Feile dreikant
Ord.No. 90/42 Feile flach
Ord.No. 90/43 Feile rund
Ord.No. 90/44 Feile halbrund
Ord.No. 90/45 Feile viereckig



Ord.No. 11/64
Lochfräser
bis ϕ 16 mm



Ord.No. 11/43
Schälbohrer mit Handgriff
bis ϕ 14 mm



Ord.No. 11/0
Set: **Ord.No. 11/1 - 11/6**

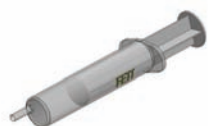

Vario Extrem Fett **Ord.No. 10/360**
Vario Extrem Grease **Ord.No. 10/360**

Schraubensicheruni: **Ord.No. 10/23**
hochfest, grün, 10 ml



Schraubensicheruni: **Ord.No. 10/24**
mittelfest, blau, 10 ml



Spiralbohrer 1,2 mm Ord.No. 11/96
Wir führen Spiral- und Gewindebohrer in
allen für die Arbeit am Modellhubschrauber
notwendigen Größen von 1,0 bis 8,0 mm

Twist drill 1.2 mm Ord.No. 11/96
We supply all required sizes of drills and
taps for the work on your model helicopter.



Ord.No. 10/123
Hochleistungs-Epoxydharz, 200 g
+ Härter, 80 g (40 Minuten)



Ord.No. 623
Poxan 30, 10 g

Klebstoffe

Aktivatorspray, 10 ml
Speedy Combine Pulver, 40 ml
Reiniger für Sekundenkleber, 20 ml
Sekundenkleber, schwarz, 20 ml
Sekundenkleber, 20 ml
für glasklare Verklebungen
Sekundenkleber dickflüssig
Sekundenkleber dünnflüssig
UHU plus endfest 300, 33 ml
UHU plus endfest 300, 53 ml
Mischdüsen
5 Stück
WELDYX Expert Kleber, 25 ml
Dosierpistole

Ord.No. 10/29
Ord.No. 10/124
Ord.No. 10/89
Ord.No. 10/126
Ord.No. 10/128

Ord.No. 10/125
Ord.No. 10/127
Ord.No. 10/27
Ord.No. 10/3
Ord.No. 10/5

Ord.No. 10/130
Ord.No. 10/1

Mit Ord.No. versehene Teile gehören nicht zum Bausatz und
müssen separat unter der jeweiligen Ord.No. bestellt werden.

Sehr geehrter Kunde,

der von Ihnen erworbene Bausatz enthält entsprechende Teile zur Erstellung eines funktionsfähigen Flugmodells.

Auf Zusammenbau, Einstellungen und Inbetriebnahme haben wir keinen Einfluß und weisen daher noch ausdrücklich darauf hin, daß Ihre individuelle Vorgehensweise einzig und allein auf Ihrem Kenntnisstand und Beurteilungsvermögen beruht.

Die Bauplanmappe dient dabei als entsprechende Orientierung, jedoch nicht als maßgeblicher Weg:

Unterschiedliche Vorgehensweisen können zum Ziel führen.

Prüfen Sie vor jedem Bauabschnitt sorgfältig Ihr Vorhaben und entscheiden Sie eigenverantwortlich über Ihren persönlichen Weg.

Dear customer,

The kit you have purchased contains the components required to build a model aircraft which is capable of flying.

We have no influence over the methods you use to assemble, set up and operate the model, and for this reason we are obliged expressly to point out to you that the methods you use rely solely on your own knowledge, experience and analytical ability.

The Plan Folder is designed to help you in this undertaking, but it does not represent a unique way of proceeding:

There are more ways than one to reach a particular destination. Before you start each stage of construction, check carefully what you intend to do, and accept the responsibility to decide on your own personal method.

Spettabile cliente,

la scatola di montaggio da voi acquistata contiene le parti necessarie per la costruzione di un modello funzionante, in grado di volare.

Per quanto riguarda i metodi per il montaggio, la messa a punto e la messa in funzione noi non abbiamo nessuna influenza e vogliamo sottolineare esplicitamente che il vostro modo d'agire dipende soltanto dal vostro livello di conoscenza e dalla vostra capacità di valutazione. Le istruzioni di montaggio servono solo per un migliore orientamento e non rappresentano l'unico modo di procedere: diversi sono i modi di procedere che possono dare l'effetto desiderato.

Prima di realizzare ogni fase di lavoro verificate attentamente il vostro progetto e scegliete in maniera responsabile il vostro obiettivo.

Cher Client,

La boîte de construction que vous avez acquise, comprend tous les composants nécessaires pour la réalisation d'un modèle d'hélicoptère fonctionnel.

Nous n'avons pas d'influence sur la manière dont vous assemblez, ajustez, et mettez en service ces composants. Nous vous informons donc expressément que votre façon de procéder dépend uniquement et exclusivement de vos connaissances, compétences et jugements. Le cahier de plans sert de guide

d'orientation, mais ne trace pas un chemin exclusif: Différentes méthodes d'opération peuvent mener au même résultat. Vérifiez avant chaque stade de construction le but à atteindre et choisissez le chemin qui vous semble le plus approprié.

Geachte klant,

De door uw gekochte bouwdoos bevat alle onderdelen om een functionerend vliegmodel te maken. Op het bouwen, afstellen en het in gebruik nemen van uw model hebben wij geen invloed, en wij wijzen er nadrukkelijk op, dat uw individuele zienswijze alleen op uw kennis en beoordelingsvermogen berust.

De bouwtekening dient daarbij alleen als een oriëntering, echter niet als een dwingend advies. Verschillende bouwconstructies kunnen tot hetzelfde doel leiden.

Test elke bouwfase zorgvuldig, en beslis over uw eigen verantwoordelijkheid m.b.t. het in gebruik nemen van uw model.

Zum Bau empfohlenes Zubehör / Further required components:

Ord.No. 1002/1000	Mechanik	
Ord.No. 3323	Elektroantriebsset H145 T2 Motor Kontronik Pyro 800/40 + Regler Kontronik Jive Pro 120+HV und alle benötigten mechanischen Antriebsteile + Montagematerial	electric drive set H145 T2
Ord.No. 510/101	Heckabtriebsset Fenestron Mechanik	
Ord.No. 147/35	Rotorwelle	rotor shaft
Ord.No. 68/50	Taumelscheibenmitnehmer	swashplate driver
Ord.No. 93/45	10-Blatt-Fenestron CFK	10-blade fenestron
Ord.No. 92/76	Fenestrongetriebe	fenestron
Ord.No. 704/36	4-Blatt-Hauptrotorkopf	4-blade main rotor head
Ord.No. 707	Scale-Rotorkopfabdeckung	scale rotor head cover
Ord.No. 404/66	4-Blatt-Satz	4-blade set
Ord.No. 70/60-4	Gestänge Set Rotorkopf	pushrod set rotor head
Ord.No. 3272 / 3273 / 3274	Bavarian Demon 3X / 3SX / AXON Flugstabilisierungs-Elektronik	Flybarless system
Ord.No. 5157	Servo Futaba BLS 452	
Ord.No. 998	Fernsteuerzubehör-Set inkl. 5 Servos Futaba BLS 452, Schalter + Zubehör	
Ord.No. 5156	Servo JR DS8411	
Ord.No. 995	Fernsteuerzubehör-Set inkl. 5 Servos JR DS8411, Schalter + Zubehör	
Ord.No. 3206	Empfänger LiPo Akku 2S 3800 mAh 3x LiPo Akku 6S 10.000-12.000 mAh	3x LiPo battery 6S 10.000-12.000 mAh
Scale-Zubehör:		
Ord.No. 147/29	Cockpit mit Innenverkleidung	Cockpit and inner couver
Ord.No. 147/5	Türbeschlagsatz komplett	Door fitting set
Ord.No. 134/624	Türgriffe	Door handles x4 1:6
Ord.No. 147/615	Haubenverschluss	Quick release latch
Ord.No. 147/62	Stator	Stator
Ord.No. 147/601	Hutzenset	Air cowls set
Ord.No. 147/56	Patiententrage	Patient stretcher
Ord.No. 147/605	Lufteinlass	Air inlet
Ord.No. 147/610	Antennenbügel	VOR antenna
Ord.No. 147/611	Heckantenne	Tail antenna
Ord.No. 147/612	Antenne Heckausleger	Antenna tail boom
Ord.No. 20/35	Turbinenattrappe	Turbine outlet 42 mm

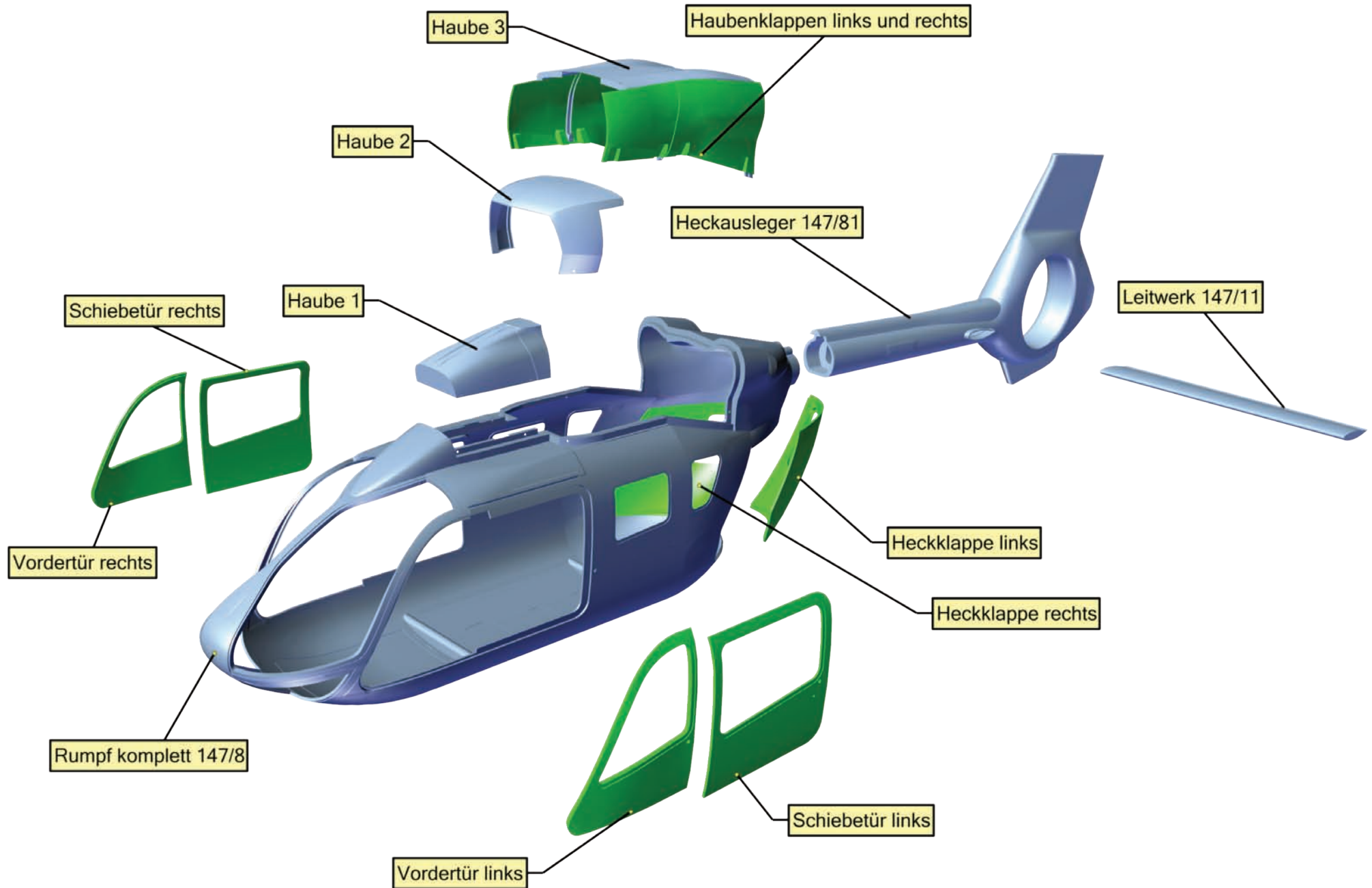

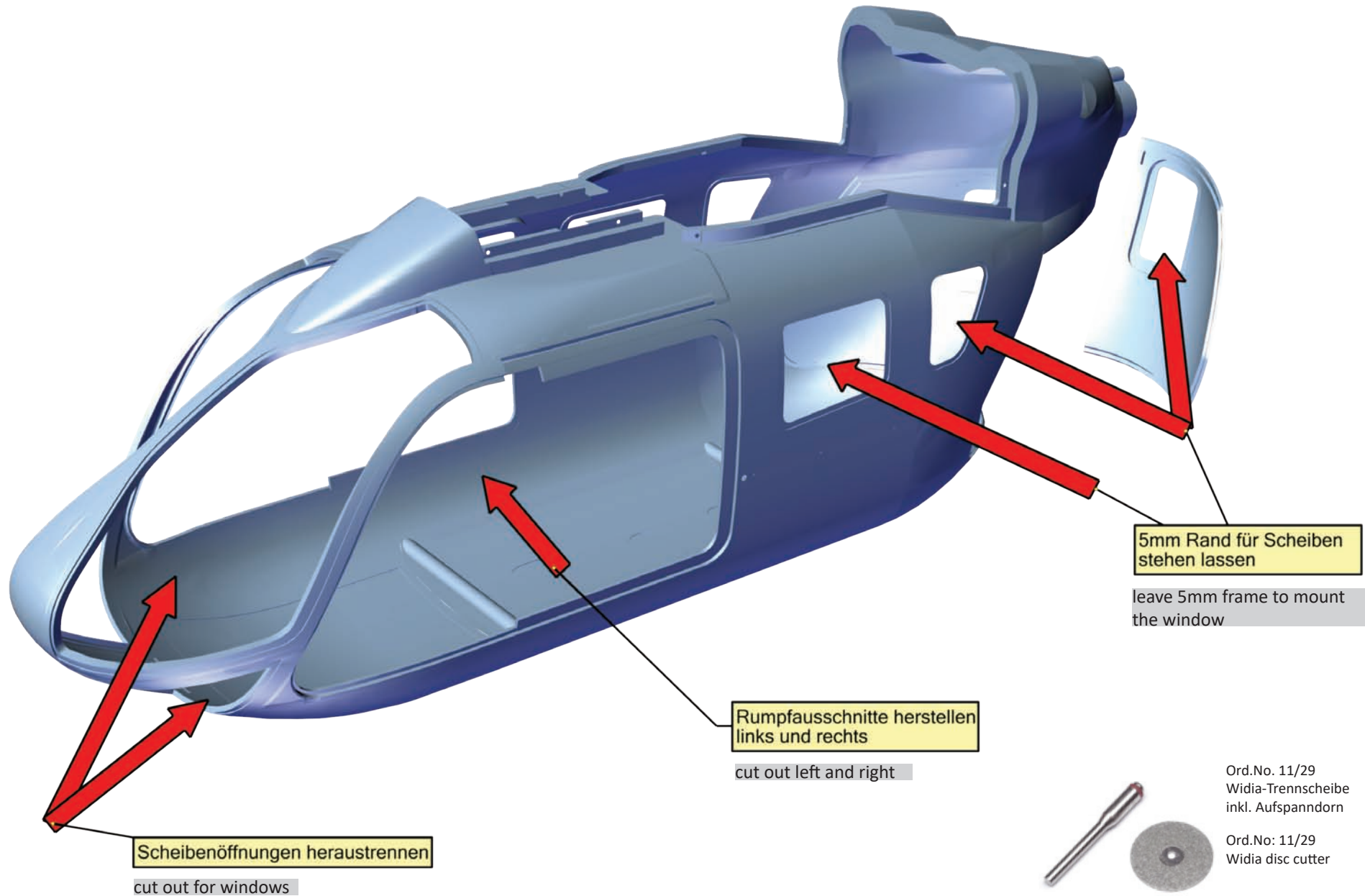

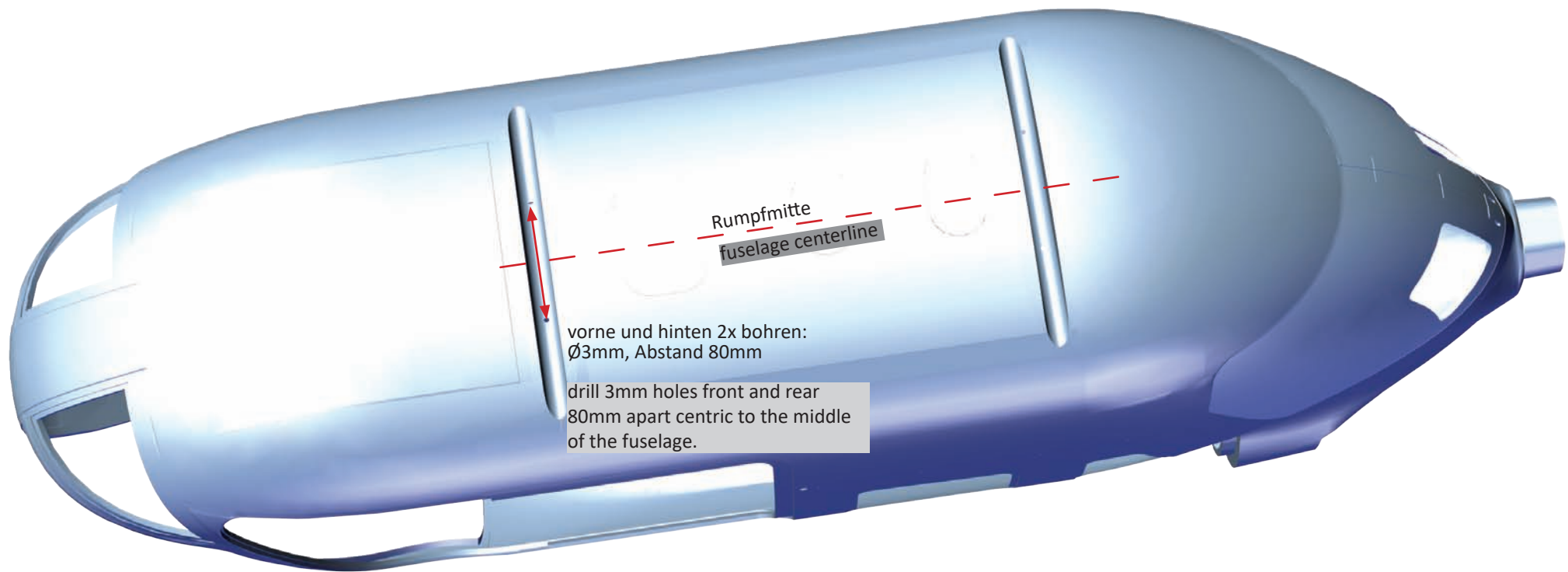

Ord.No. 11/98 Spiralbohrer 3mm
Ord.No. 11/98 Twist drill 3.0 mm

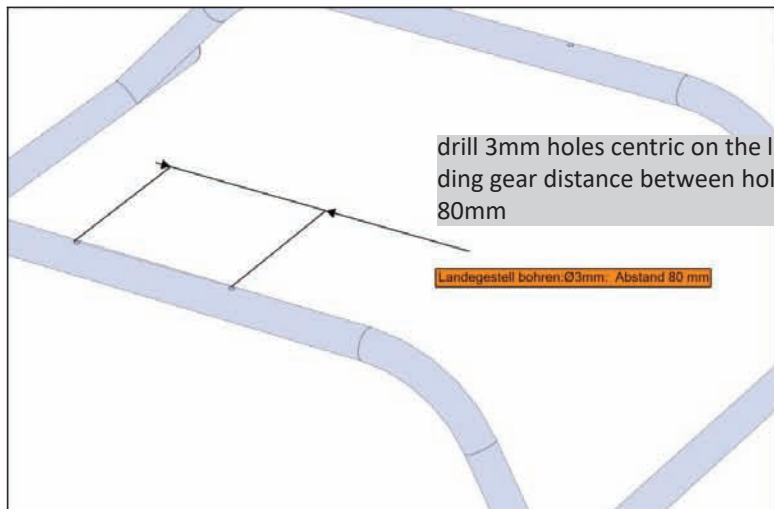
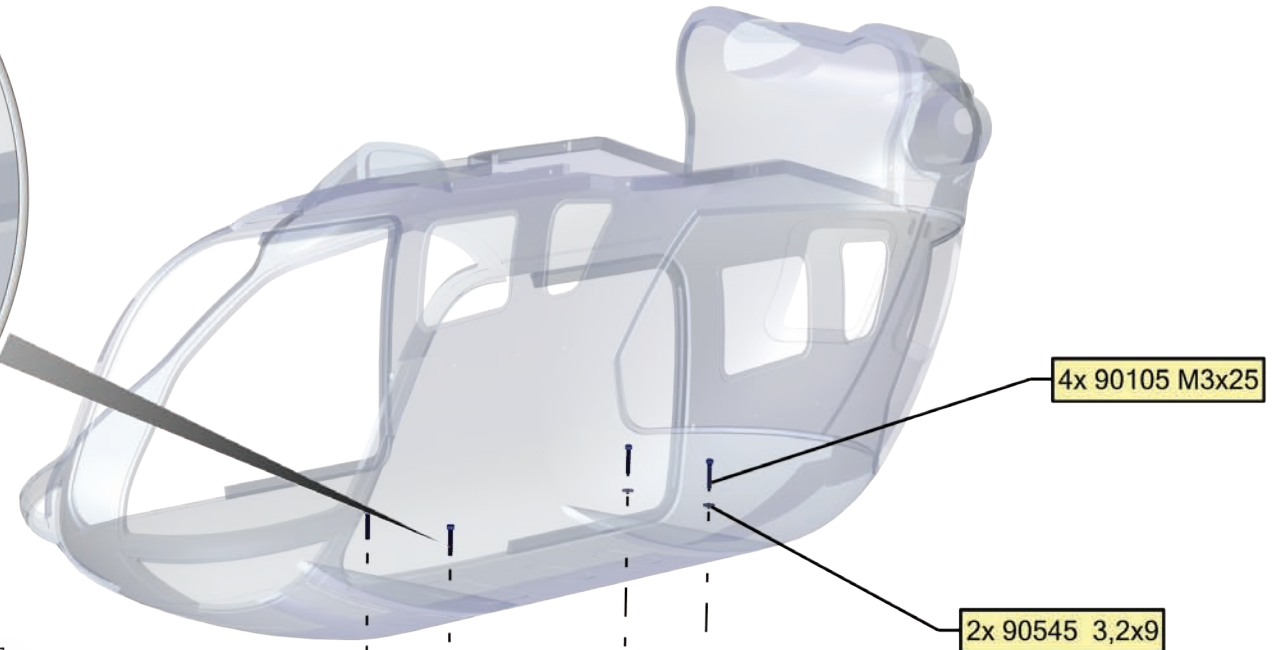
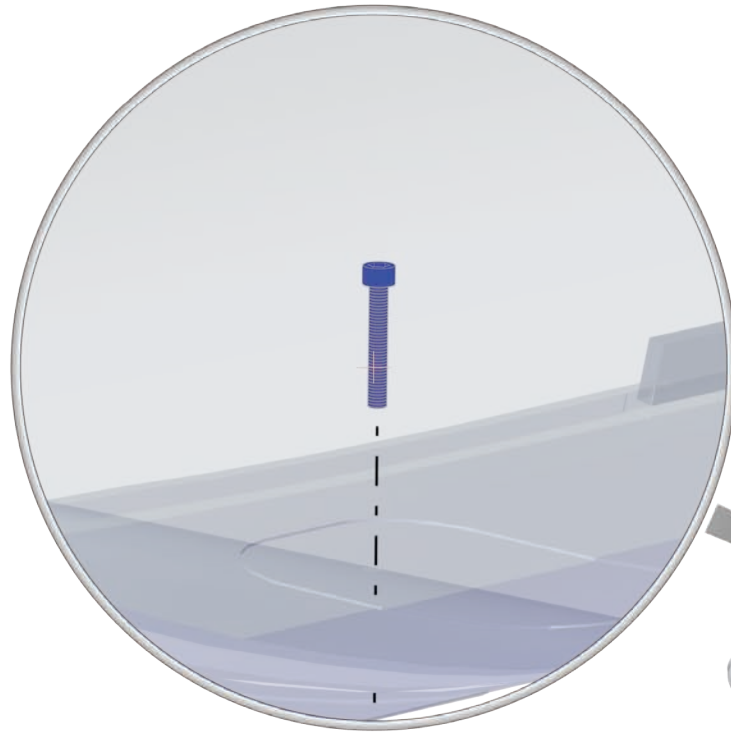

Landegestell 147/1

4x 90530 Stopmutter M3

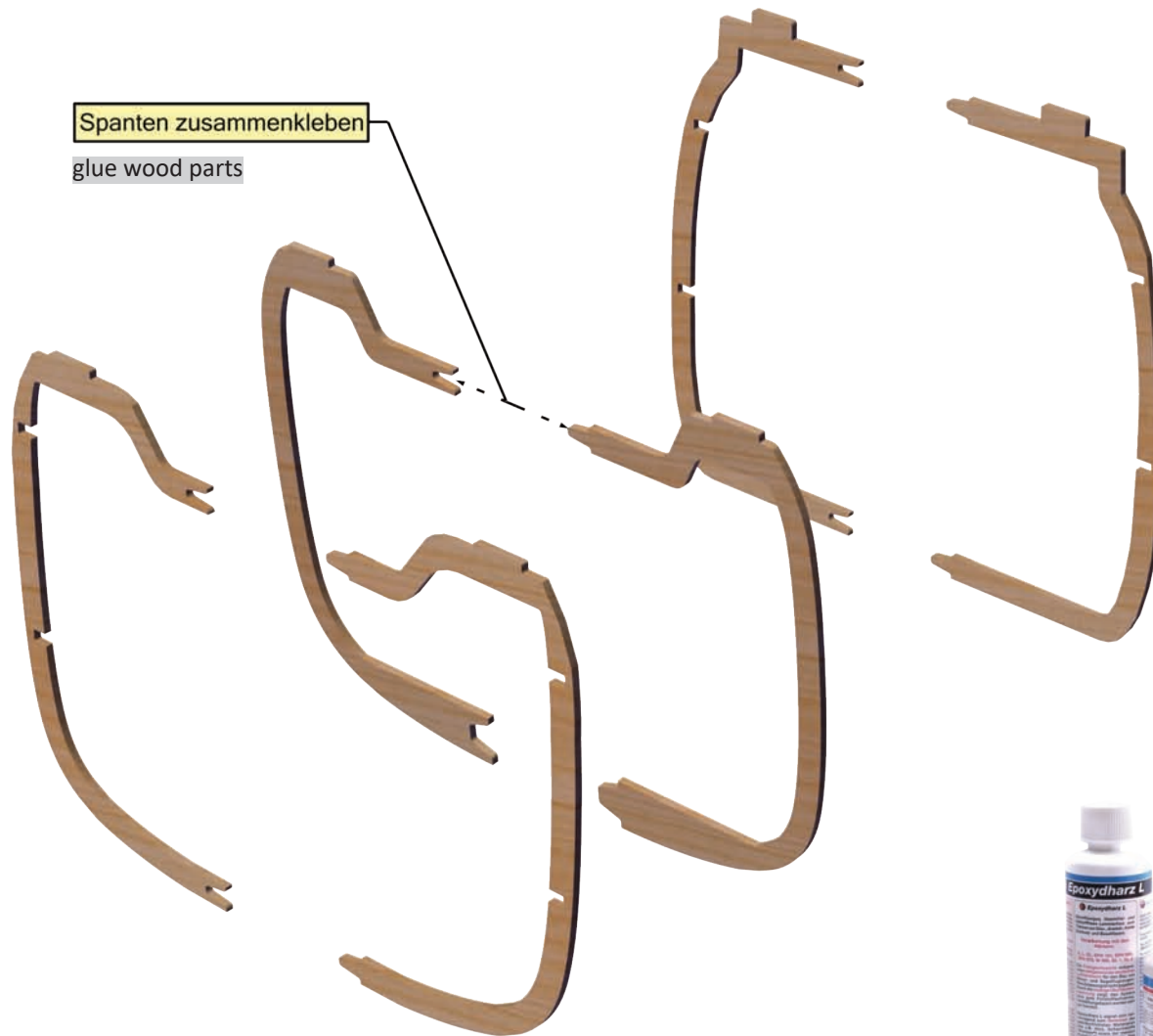

Ord.No. 10/123
Hochleistungs-Epoxydharz, 200 g
+ Härter, 80 g (40 Minuten)



Ord.No. 623
Poxan 30, 10 g

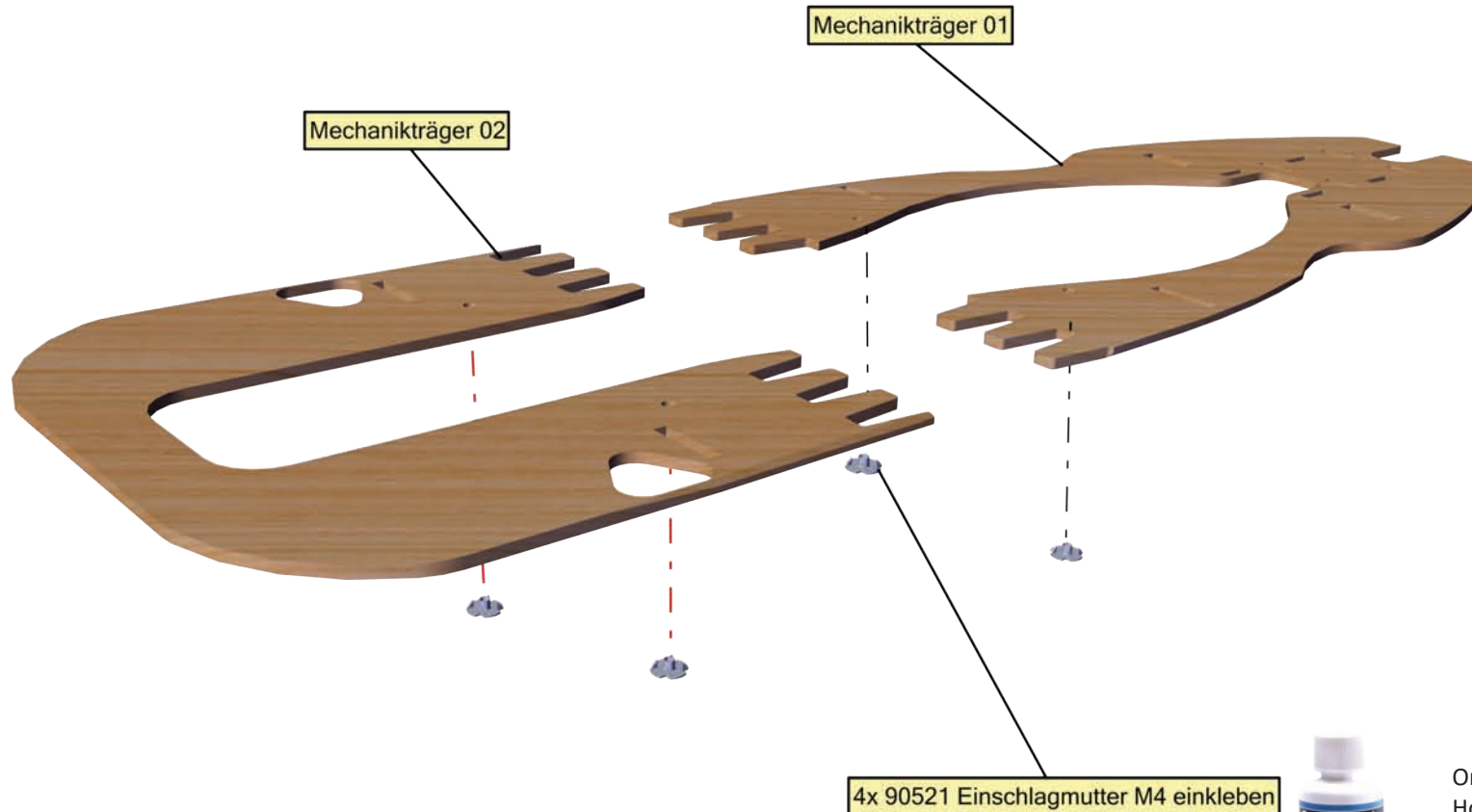

Ord.No. 10/123
Hochleistungs-Epoxydharz, 200 g
+ Härter, 80 g (40 Minuten)



Ord.No. 623
Poxan 30, 10 g

Mechanikträger und Heckspant lose
im Rumpf zusammen stecken. Nicht verkleben

dry fit all wood parts
(do not glue yet)

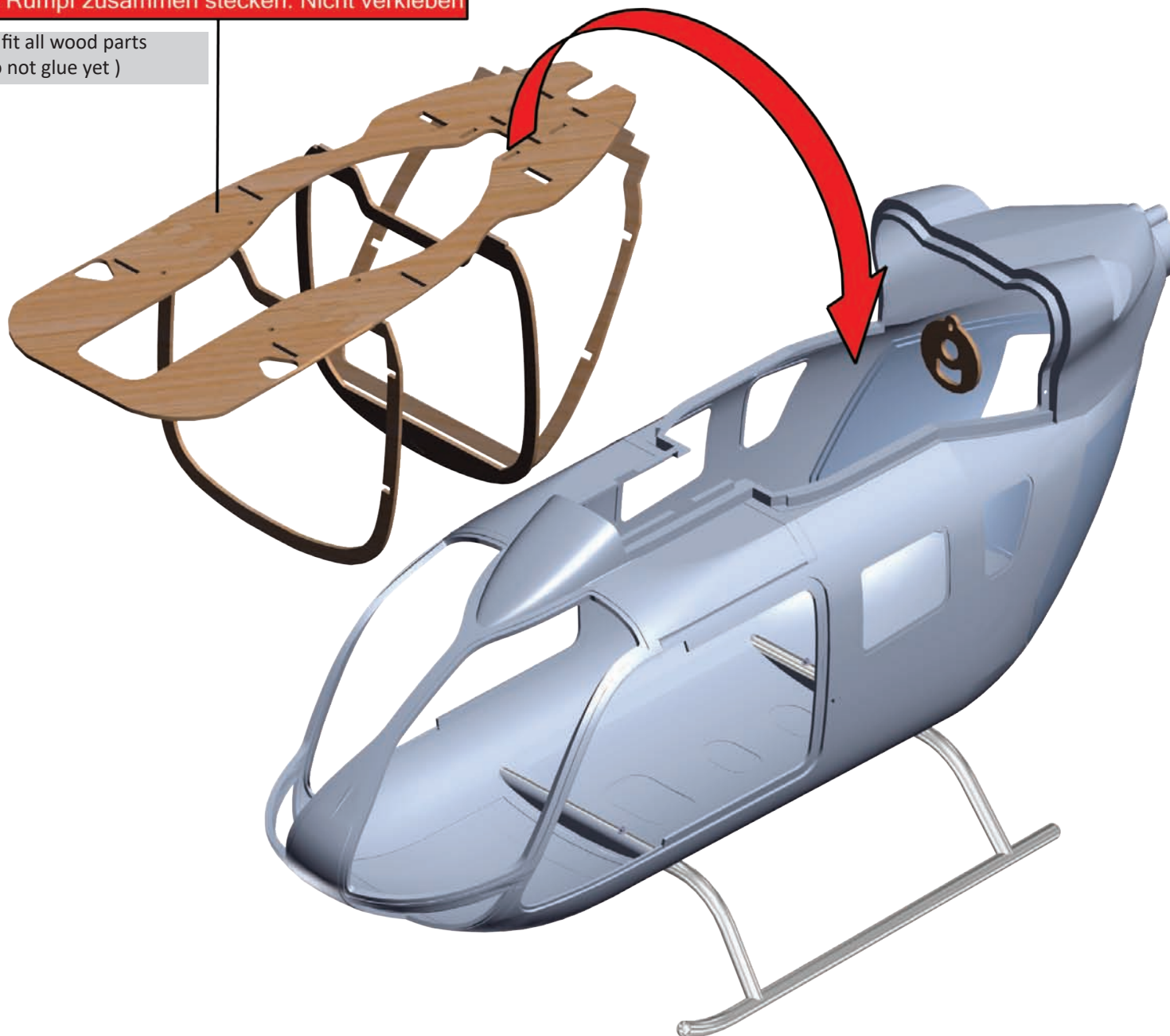

Spannen nur lose einsetzen
nicht verkleben

dry fit all wood parts
(do not glue yet)

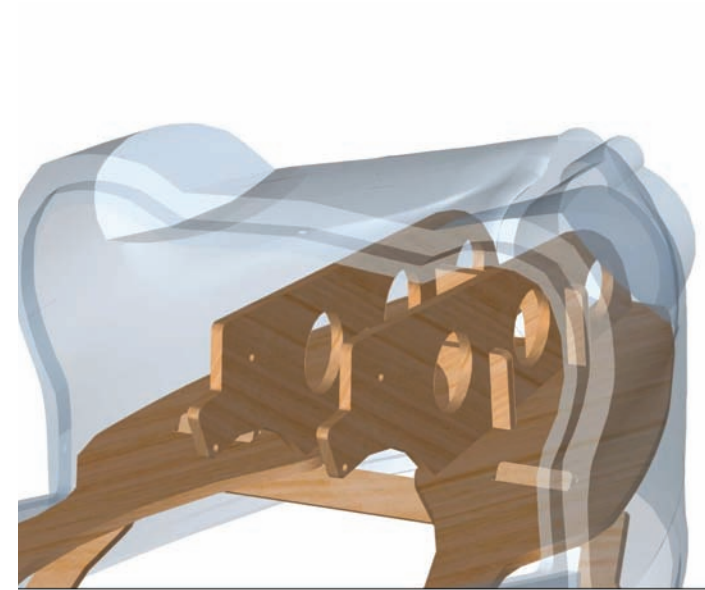
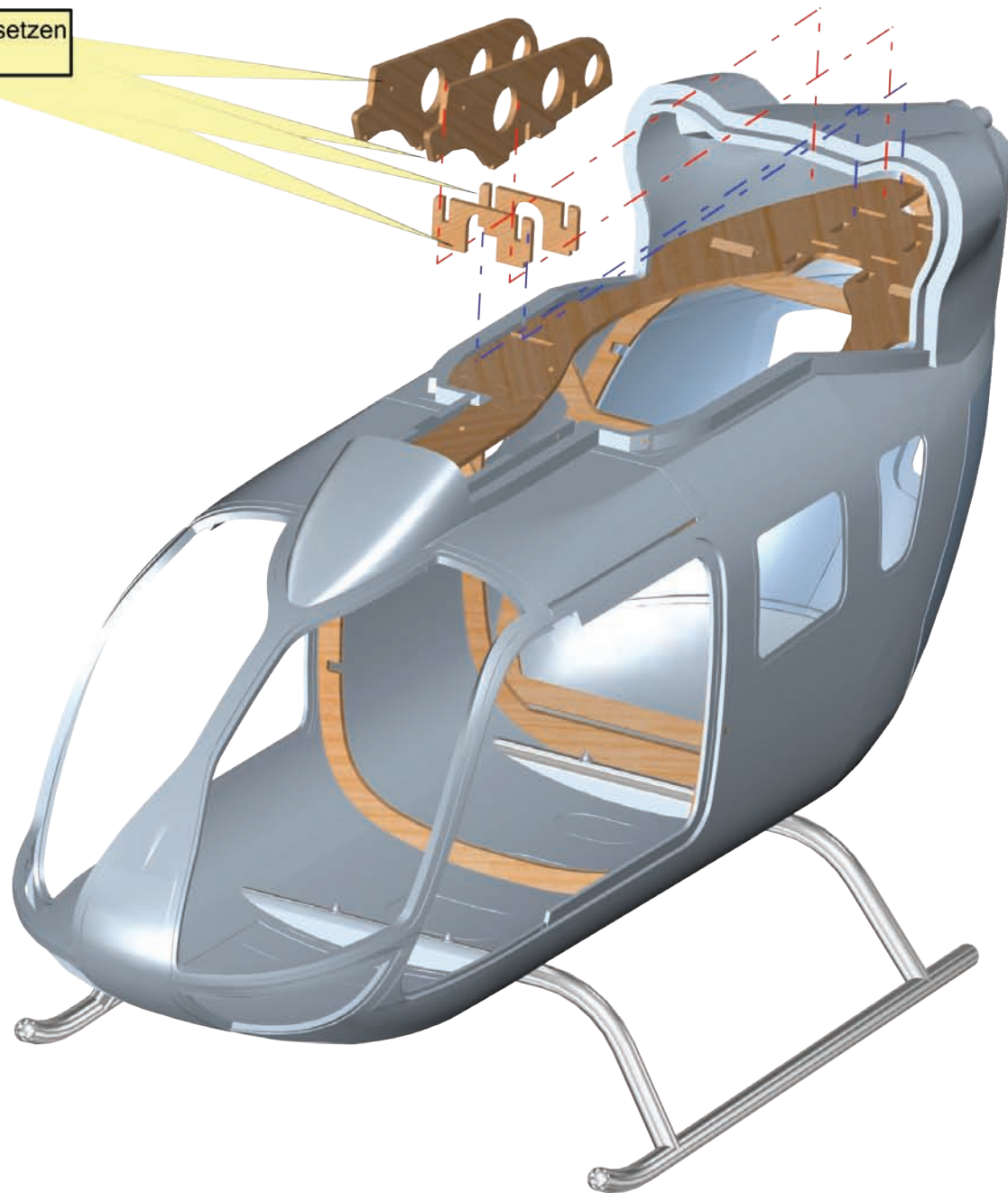

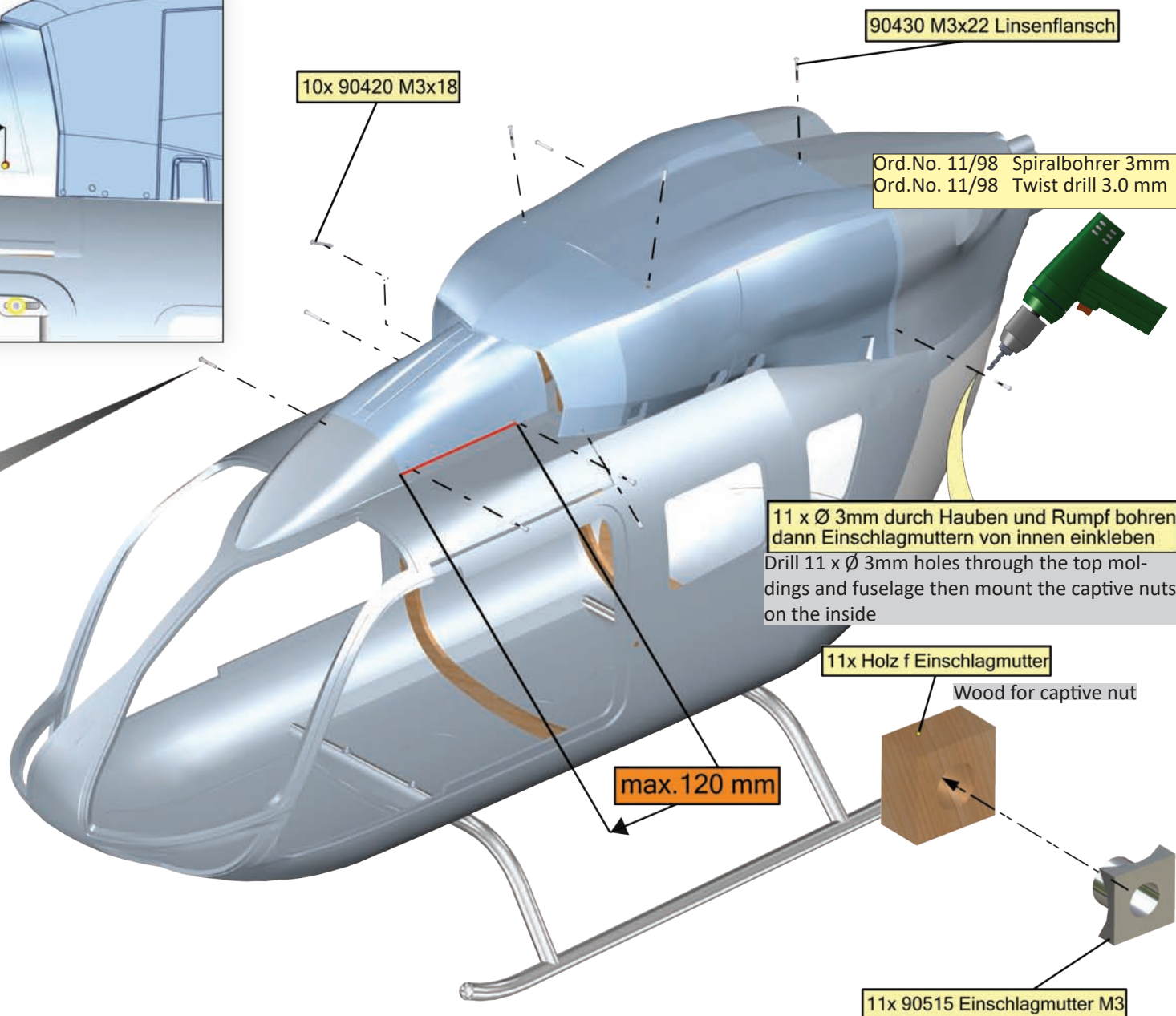
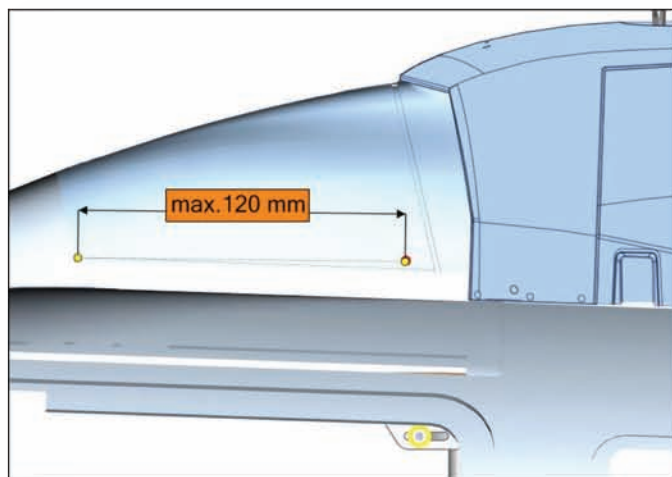

Ord.No. 10/123
Hochleistungs-Epoxydharz, 200 g
+ Härter, 80 g (40 Minuten)



Ord.No. 623
Poxan 30, 10 g

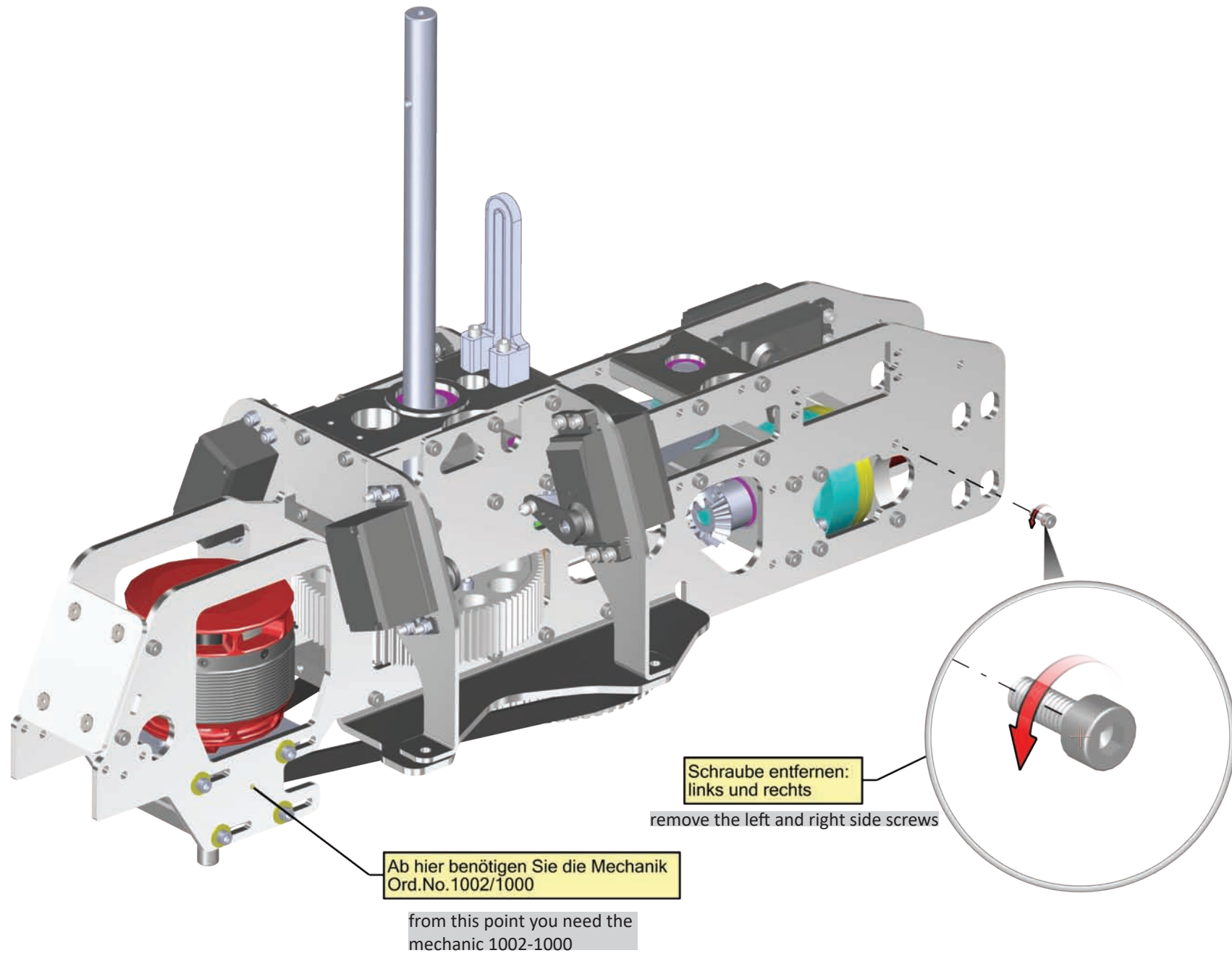

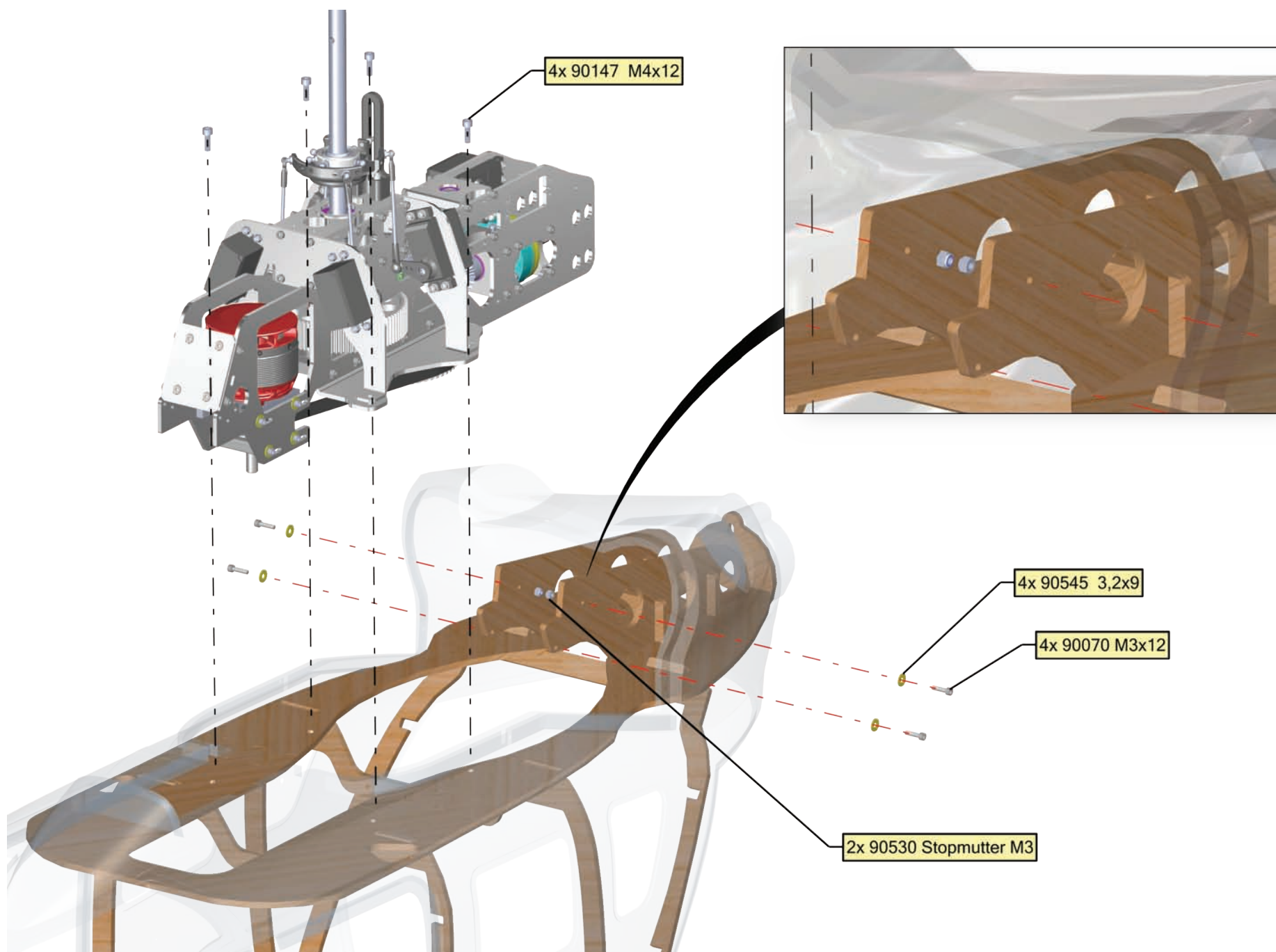

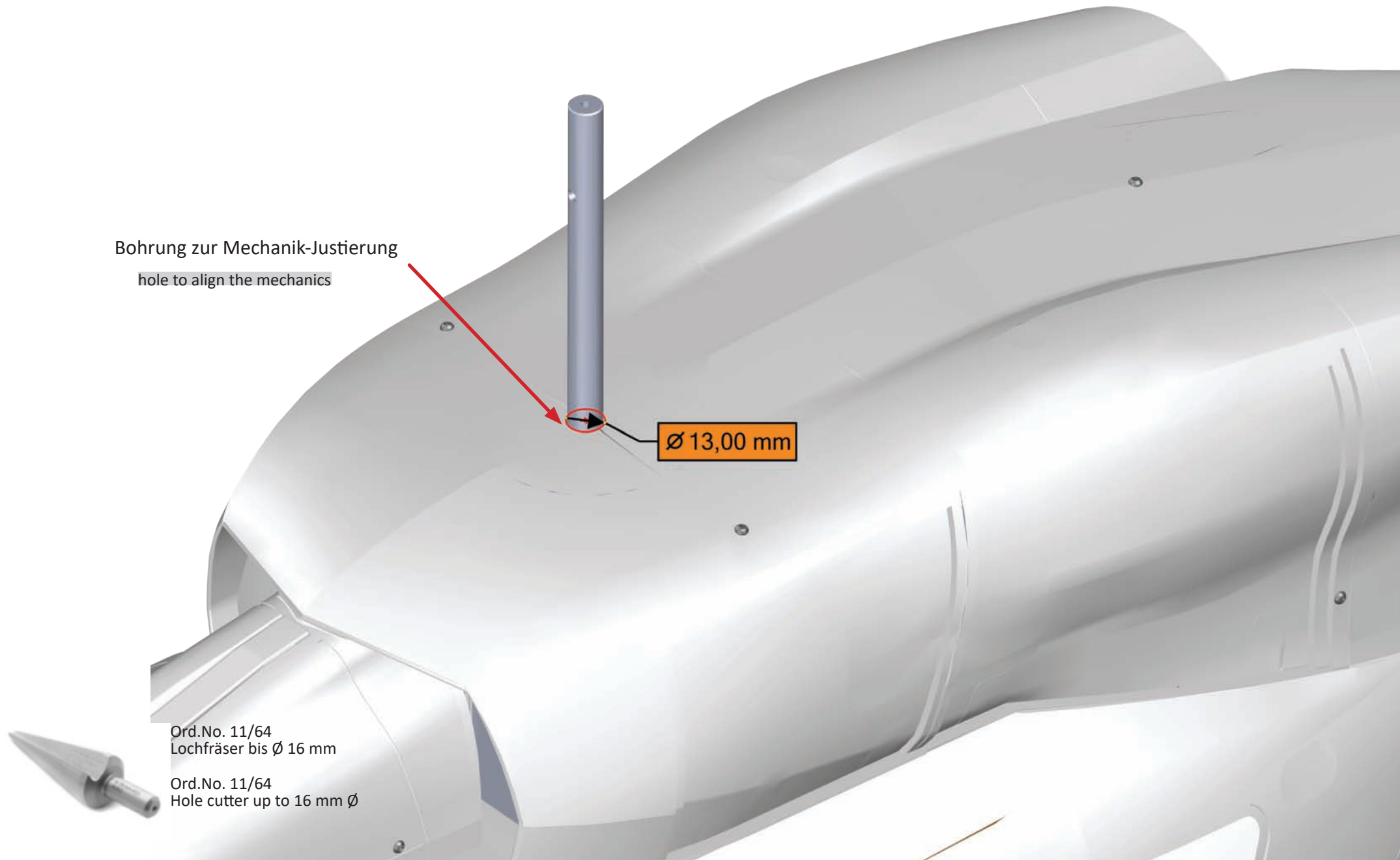

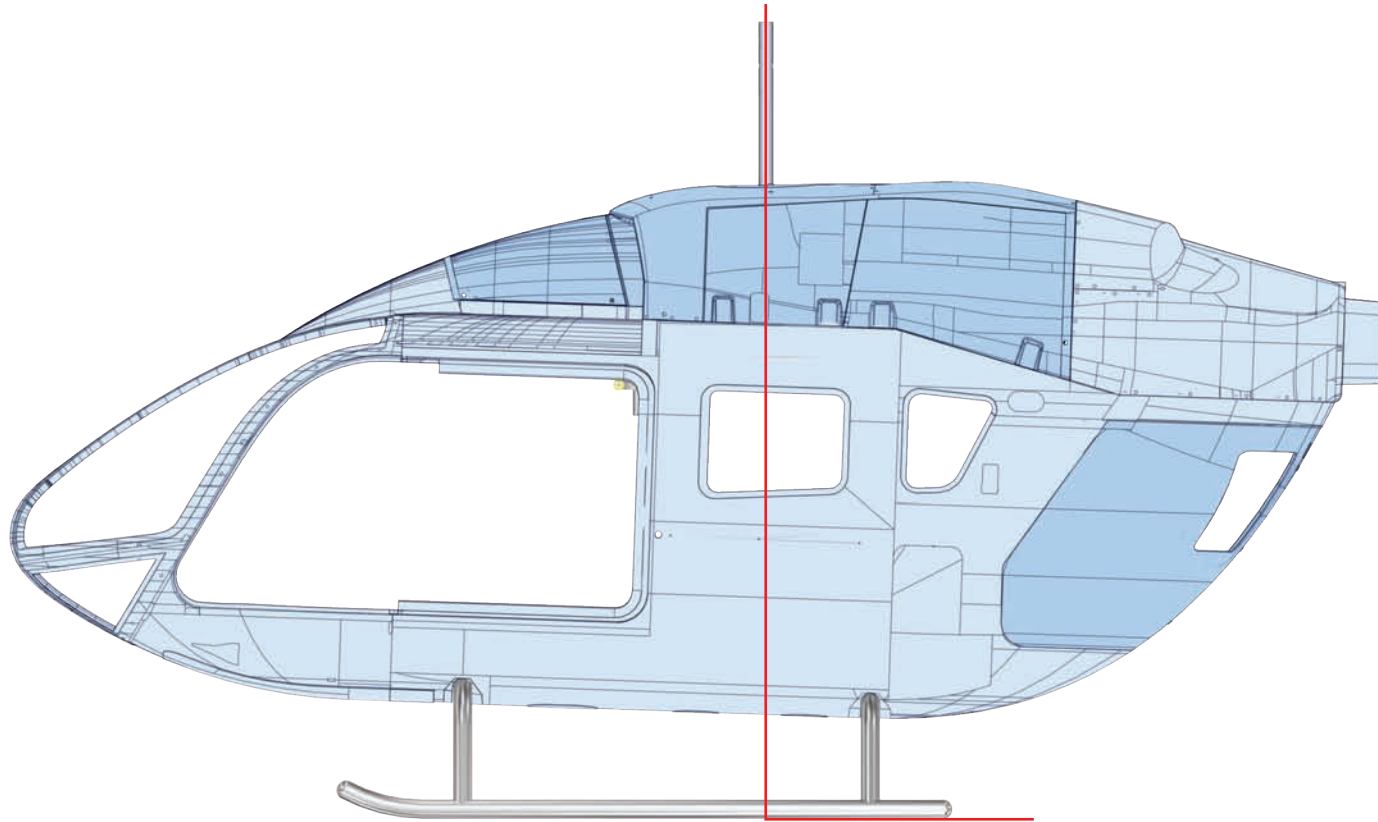

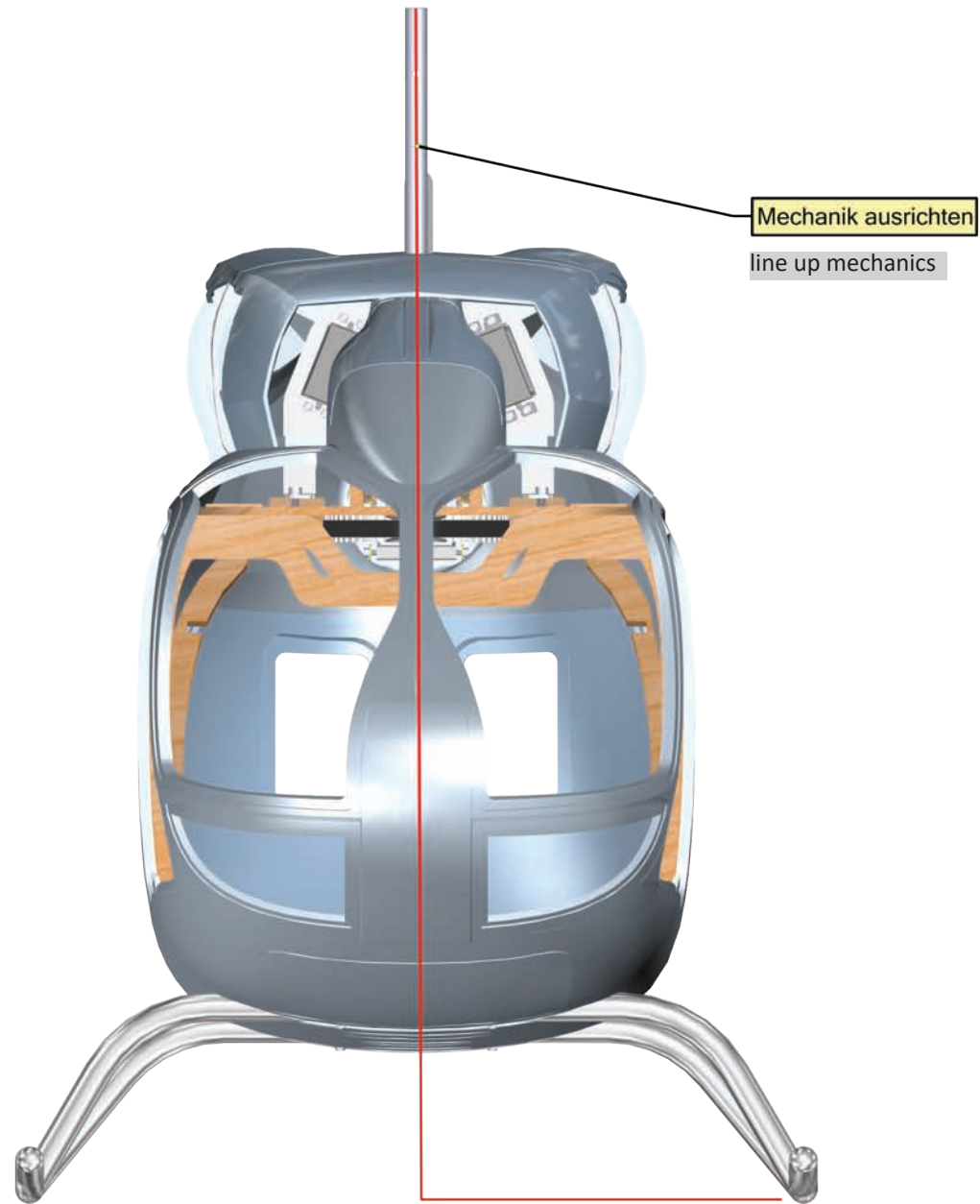

alles ausrichten,
noch nicht festkleben

adjust / line up eve-
rything, but do not glue
the wood parts yet

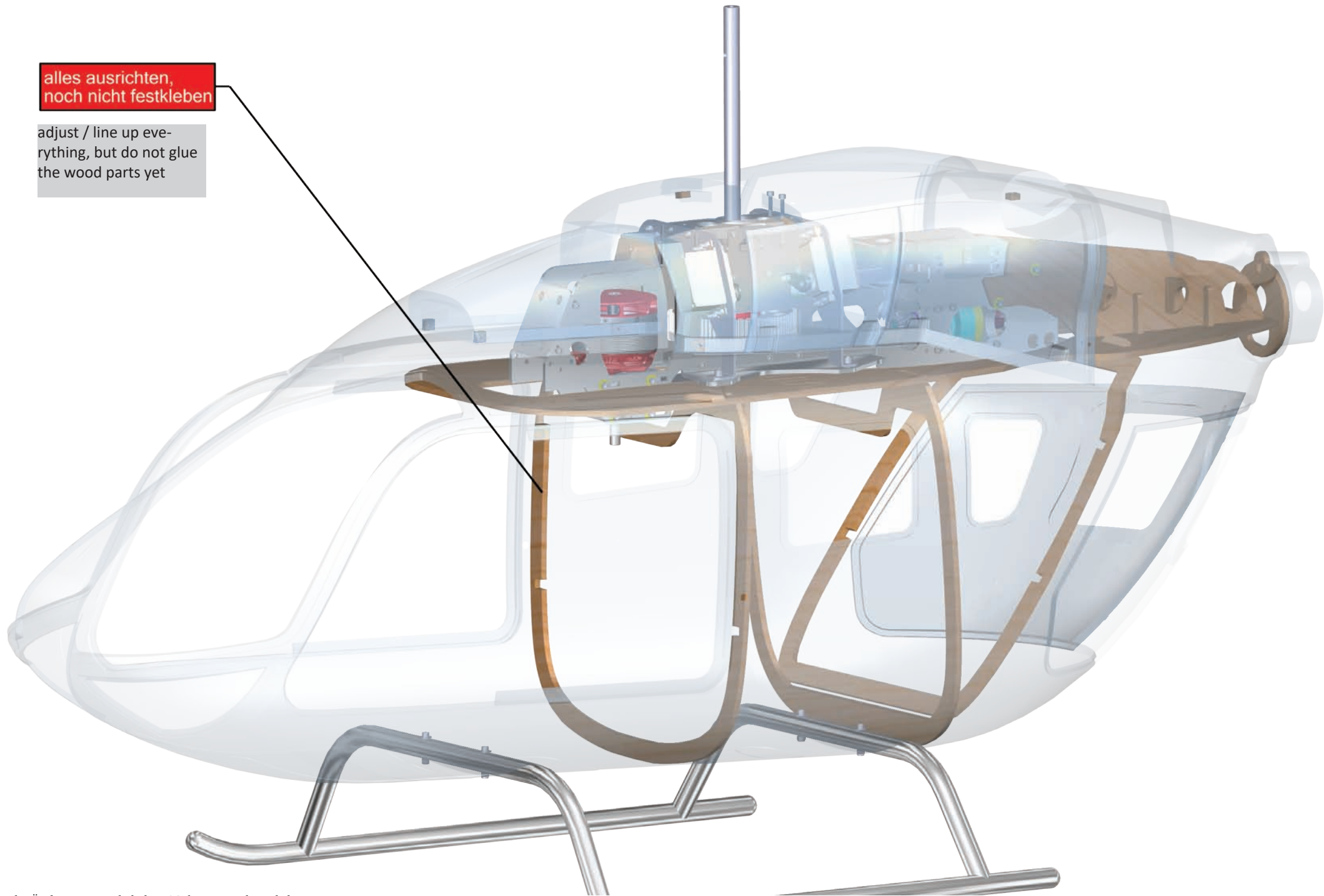

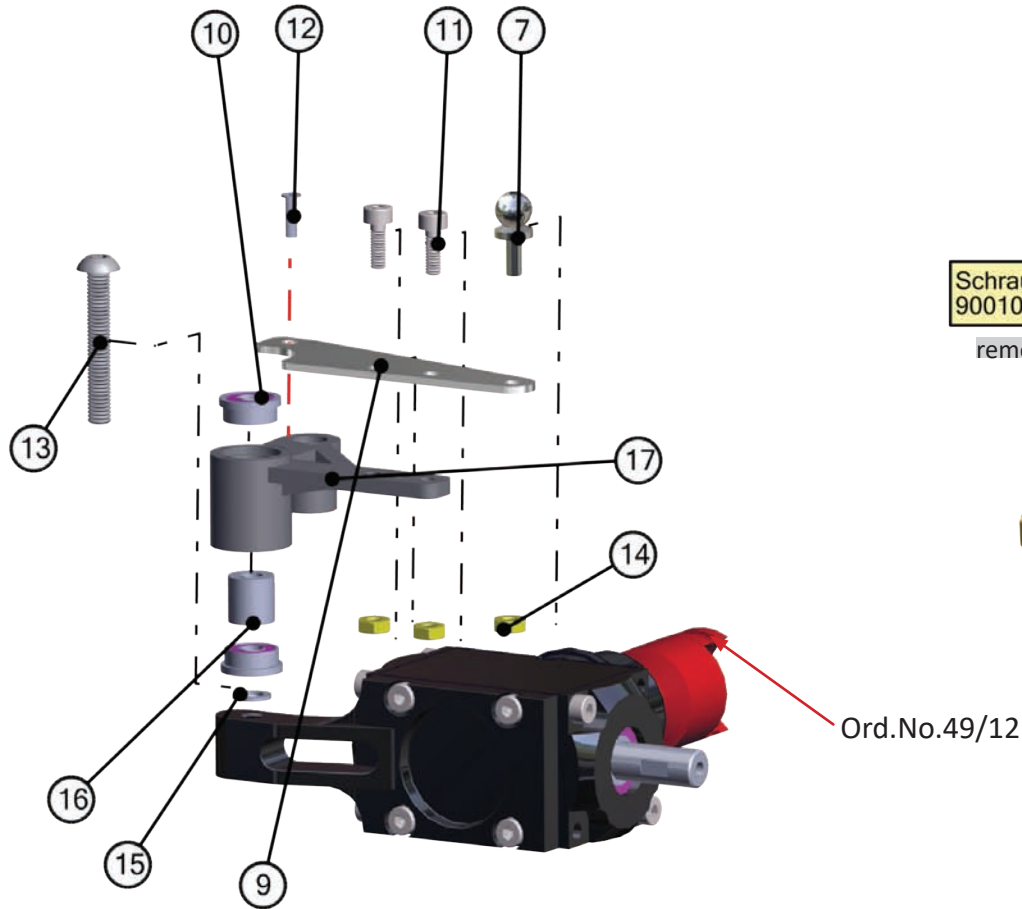

Schrauben entfernen:
90010= M2x6
remove M2x6 bolts

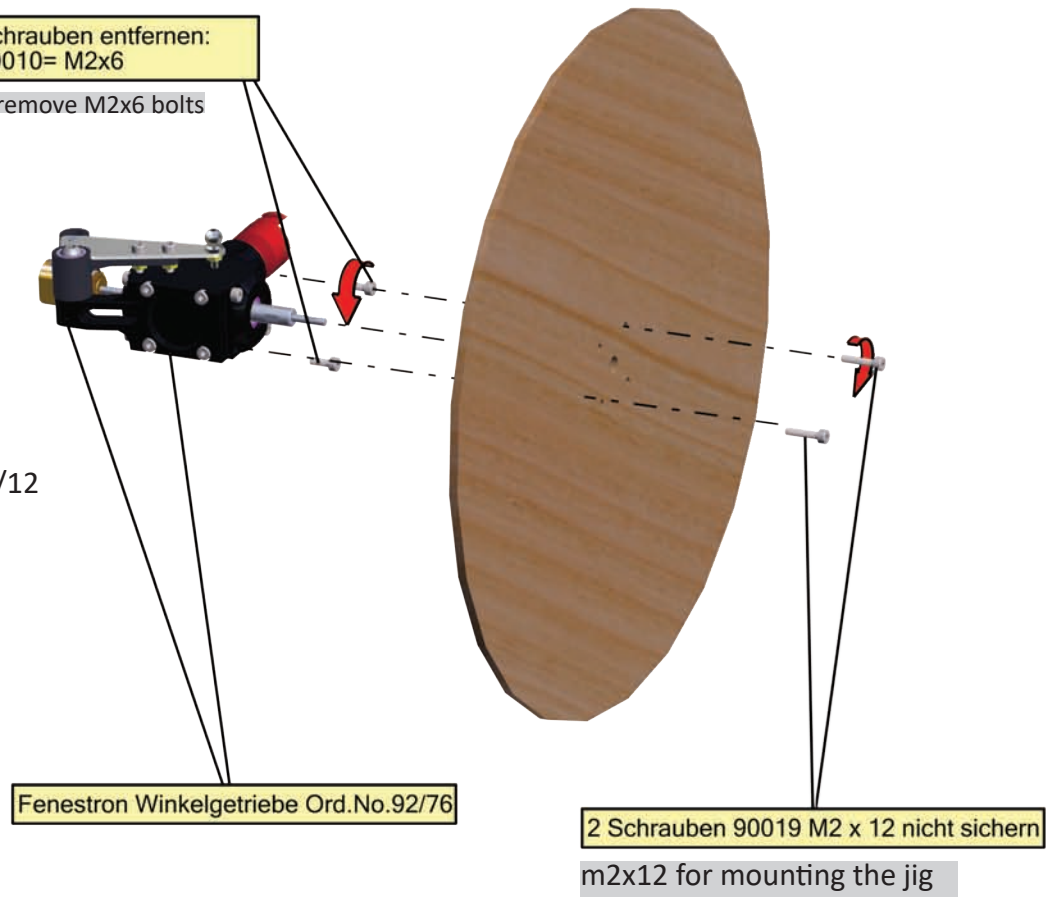

Pos.No.	Ord.No.	Menge
17	97_30	1
16	97-7	1
15	90810 3x5x0,5	1
14	90485 Mutter M2	3
13	90425 3x20 Linsenkopf	1
12	90222 Blechtreib 1,6x6	1
11	90010 M2 x 6	2
10	71-11 Bundlager 3x7x3	2
9	342-96	1
7	060	1

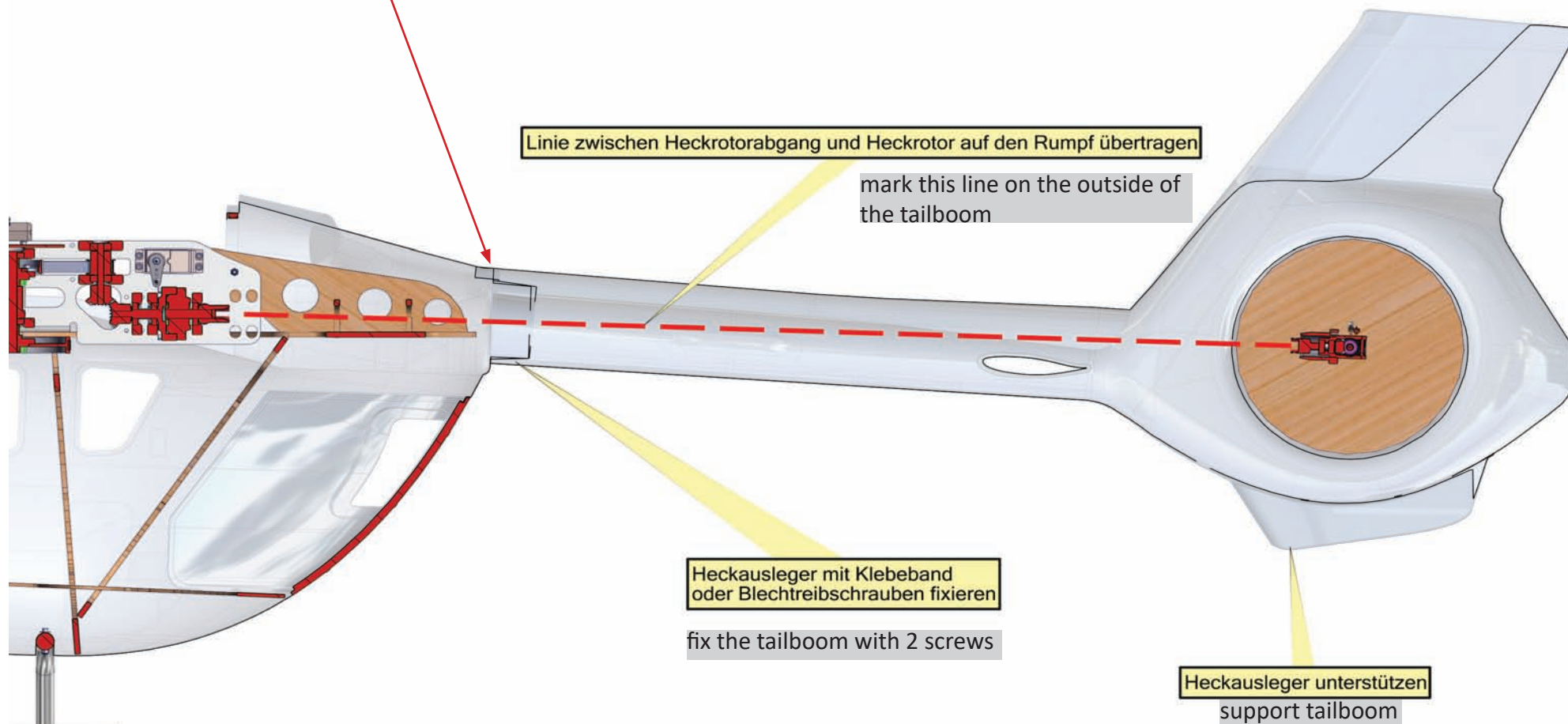
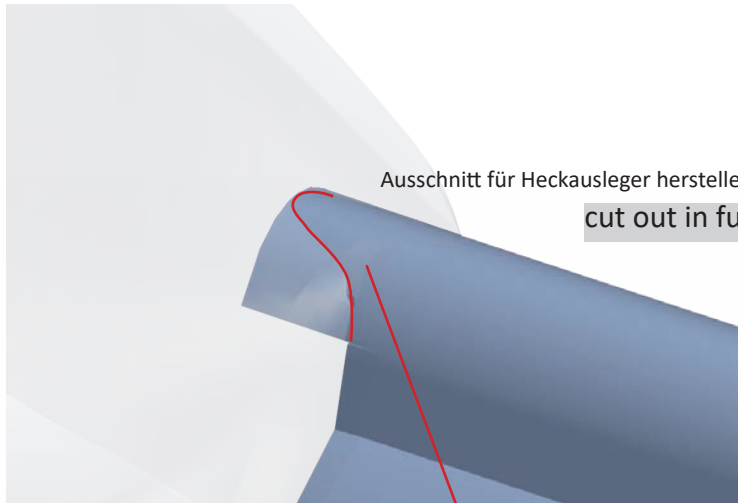

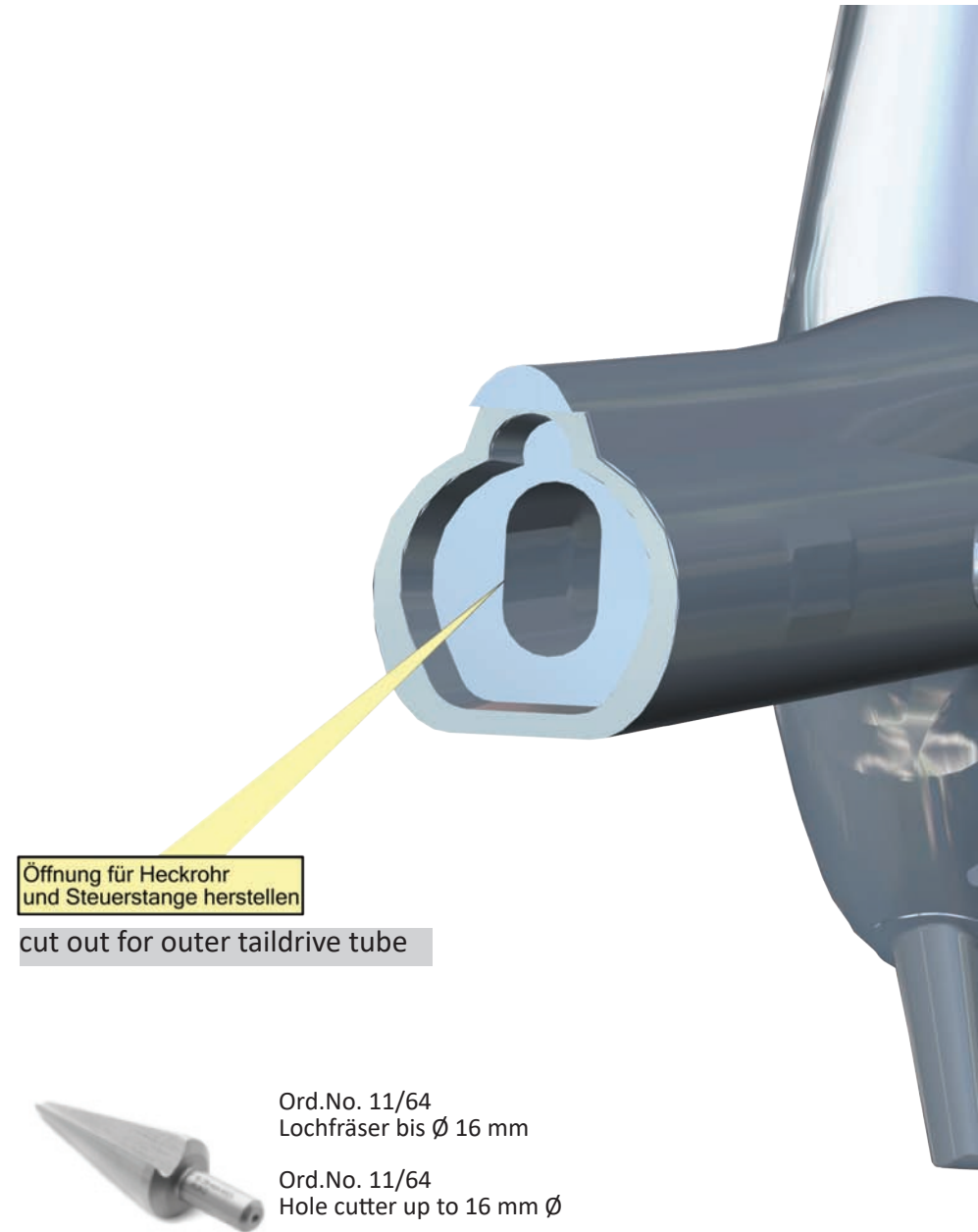
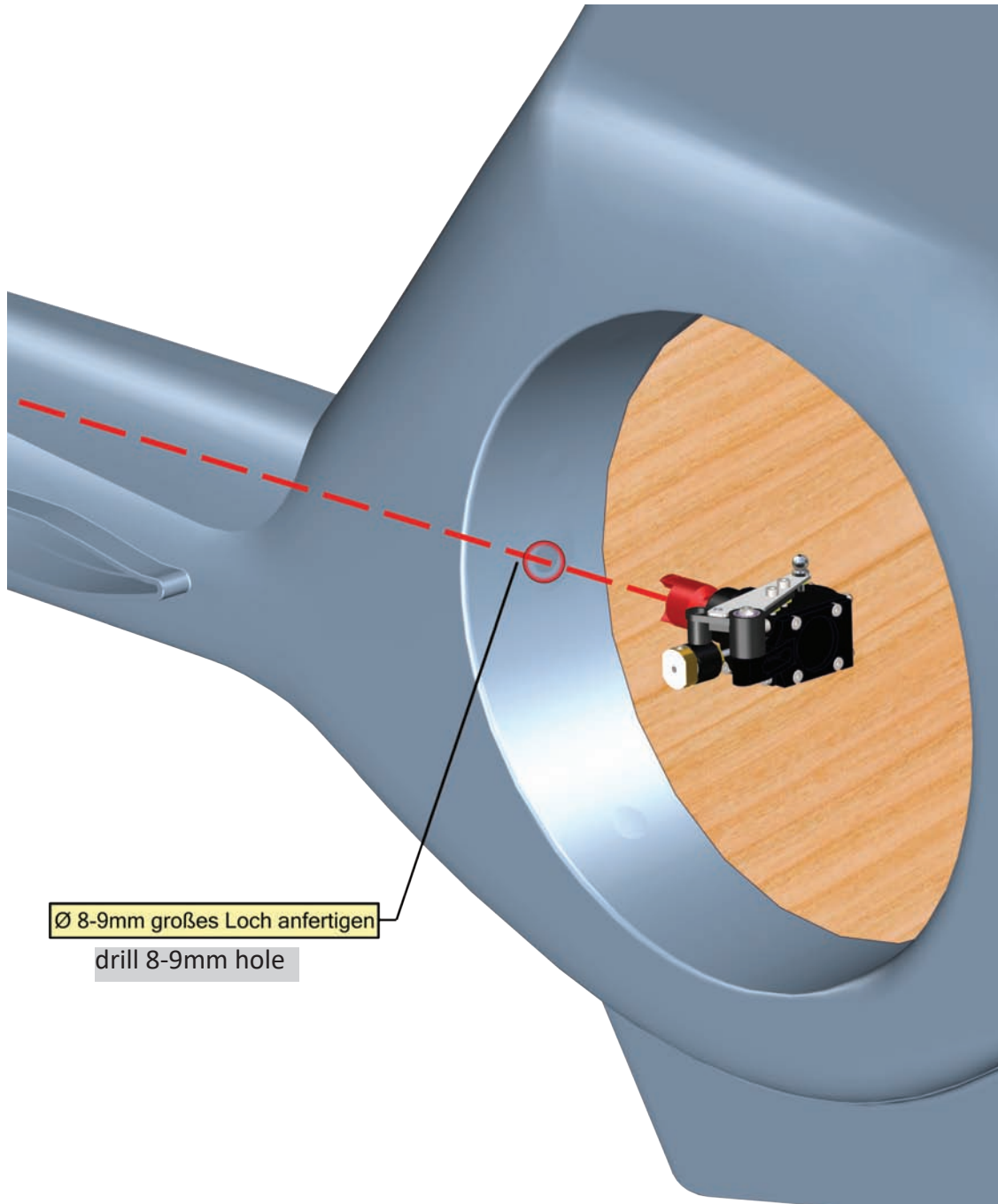

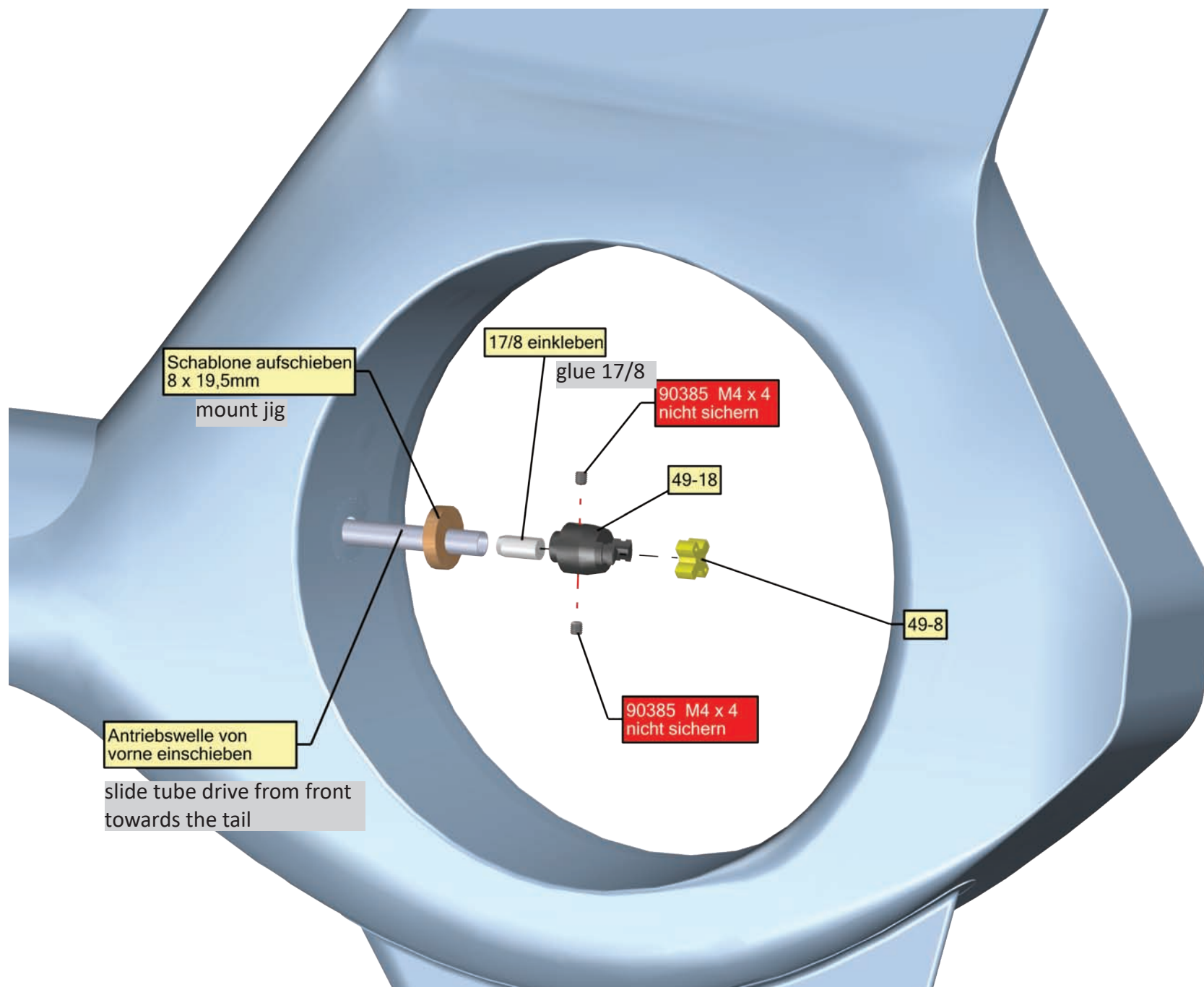

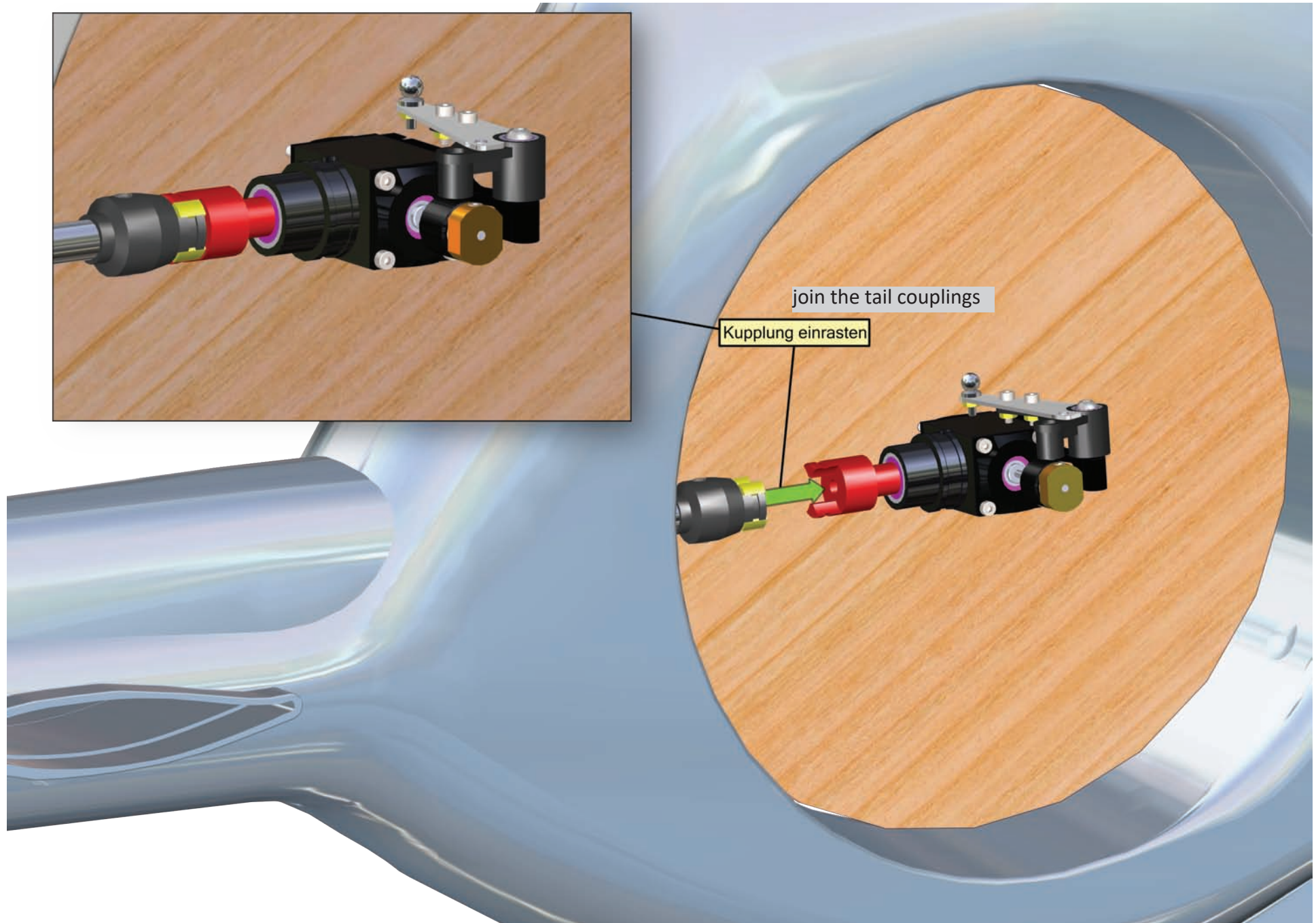

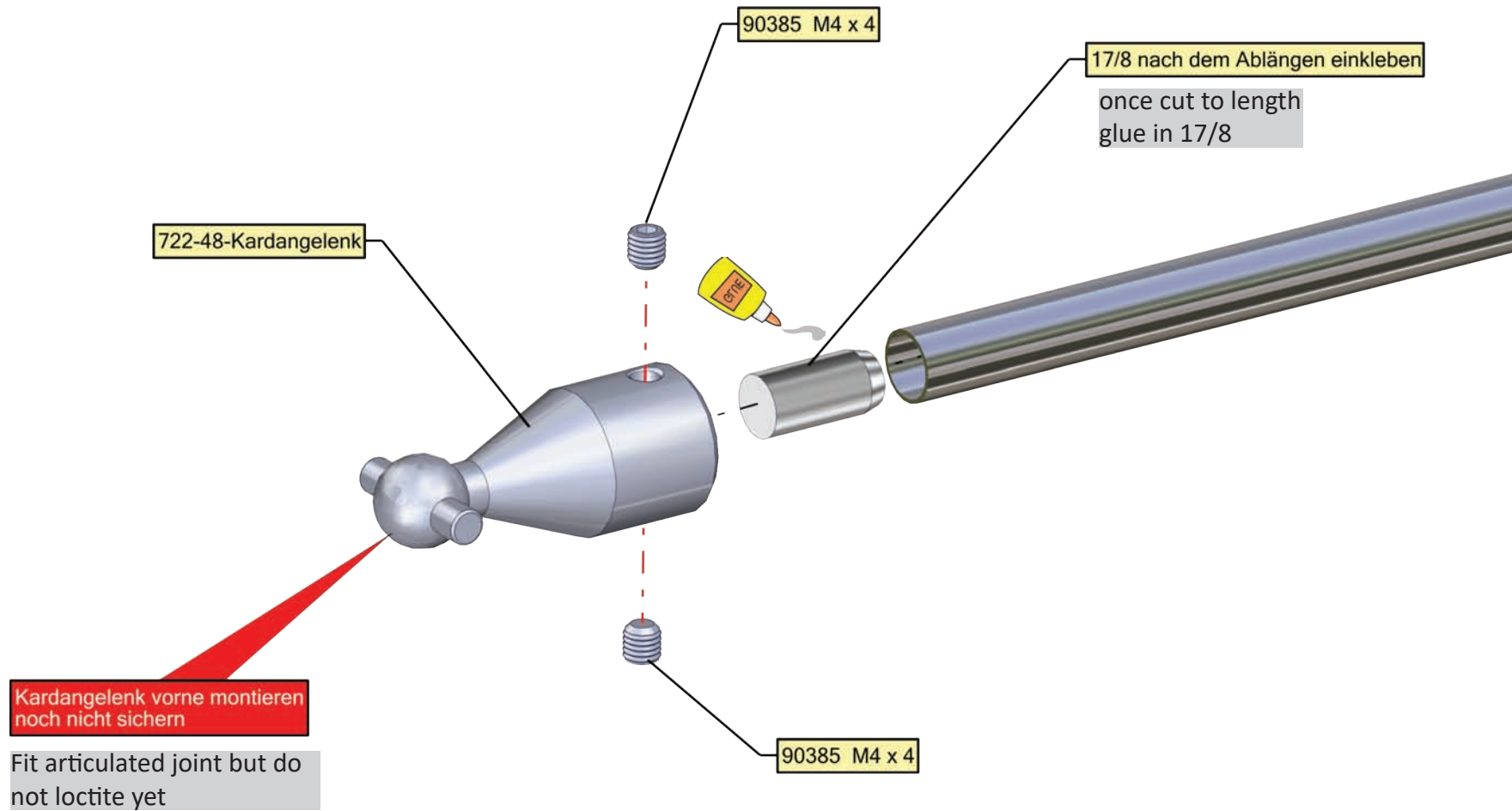

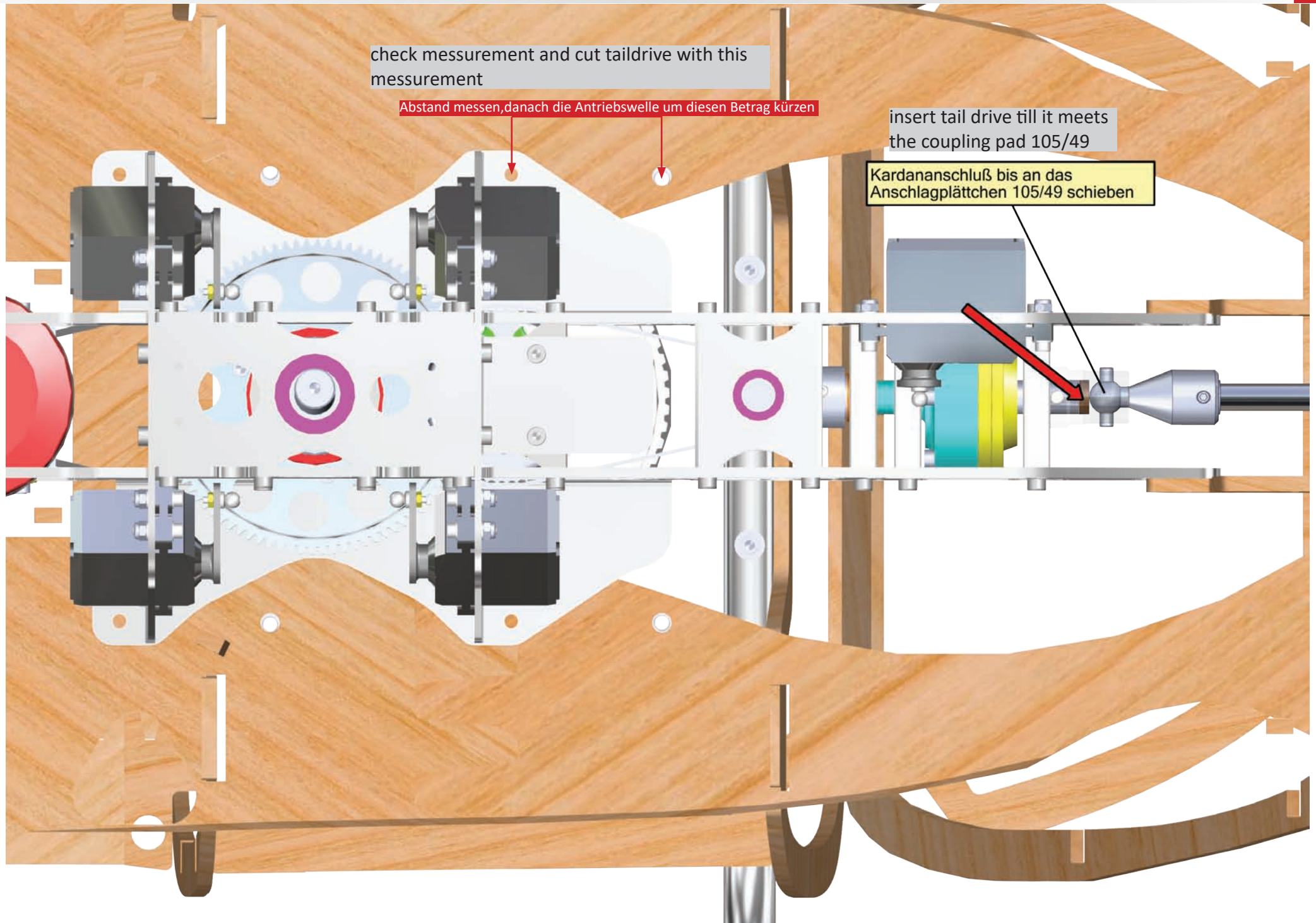

check messurement and cut taildrive with this
messurement

Abstand messen, danach die Antriebswelle um diesen Betrag kürzen

insert tail drive till it meets
the coupling pad 105/49

Kardananschluß bis an das
Anschlagplättchen 105/49 schieben

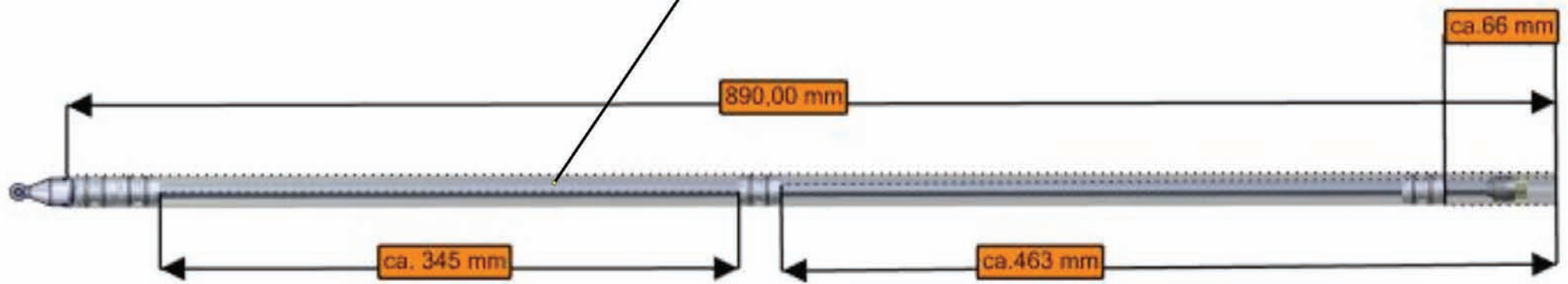
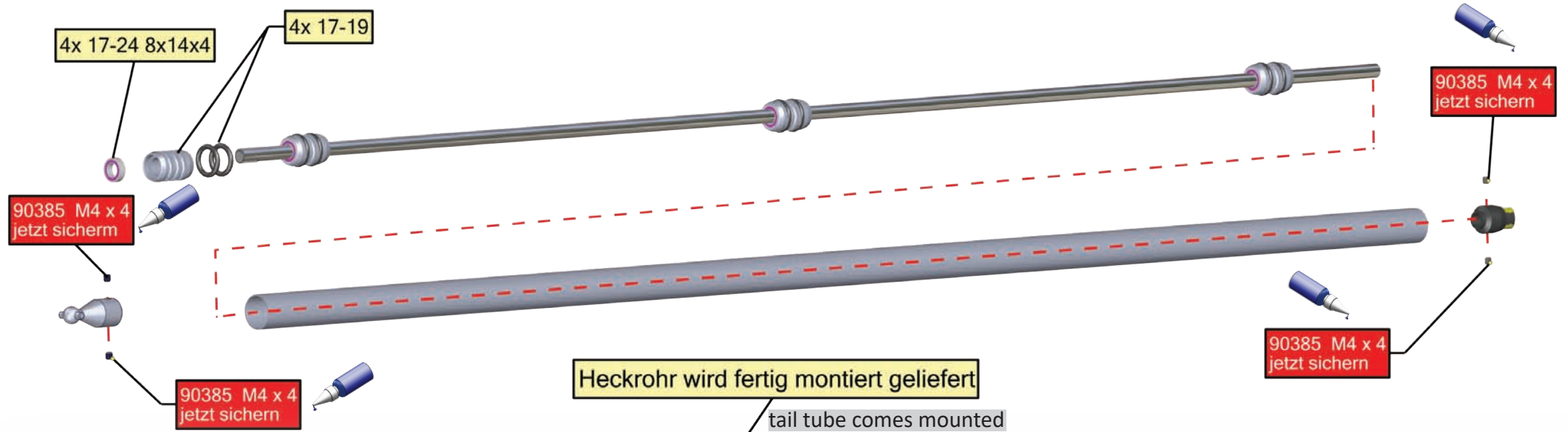

Ord.No.10/24
Schraubensicherung mittelfest
Thread-lock fluid medium-strength, 10ml

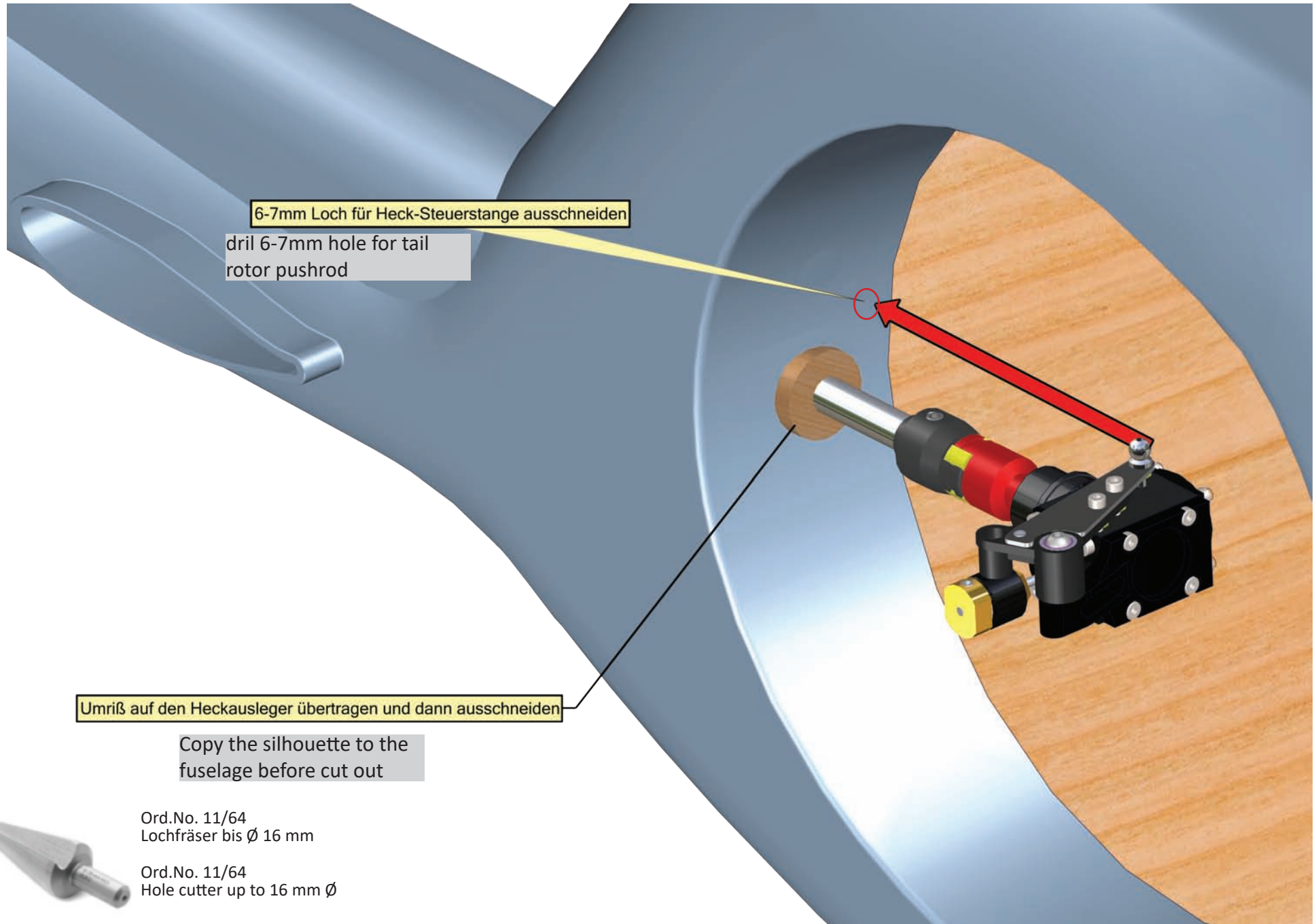

6-7mm Loch für Heck-Steuerstange ausschneiden
dril 6-7mm hole for tail rotor pushrod

Umriss auf den Heckausleger übertragen und dann ausschneiden
Copy the silhouette to the fuselage before cut out



Ord.No. 11/64
Lochfräser bis Ø 16 mm

Ord.No. 11/64
Hole cutter up to 16 mm Ø

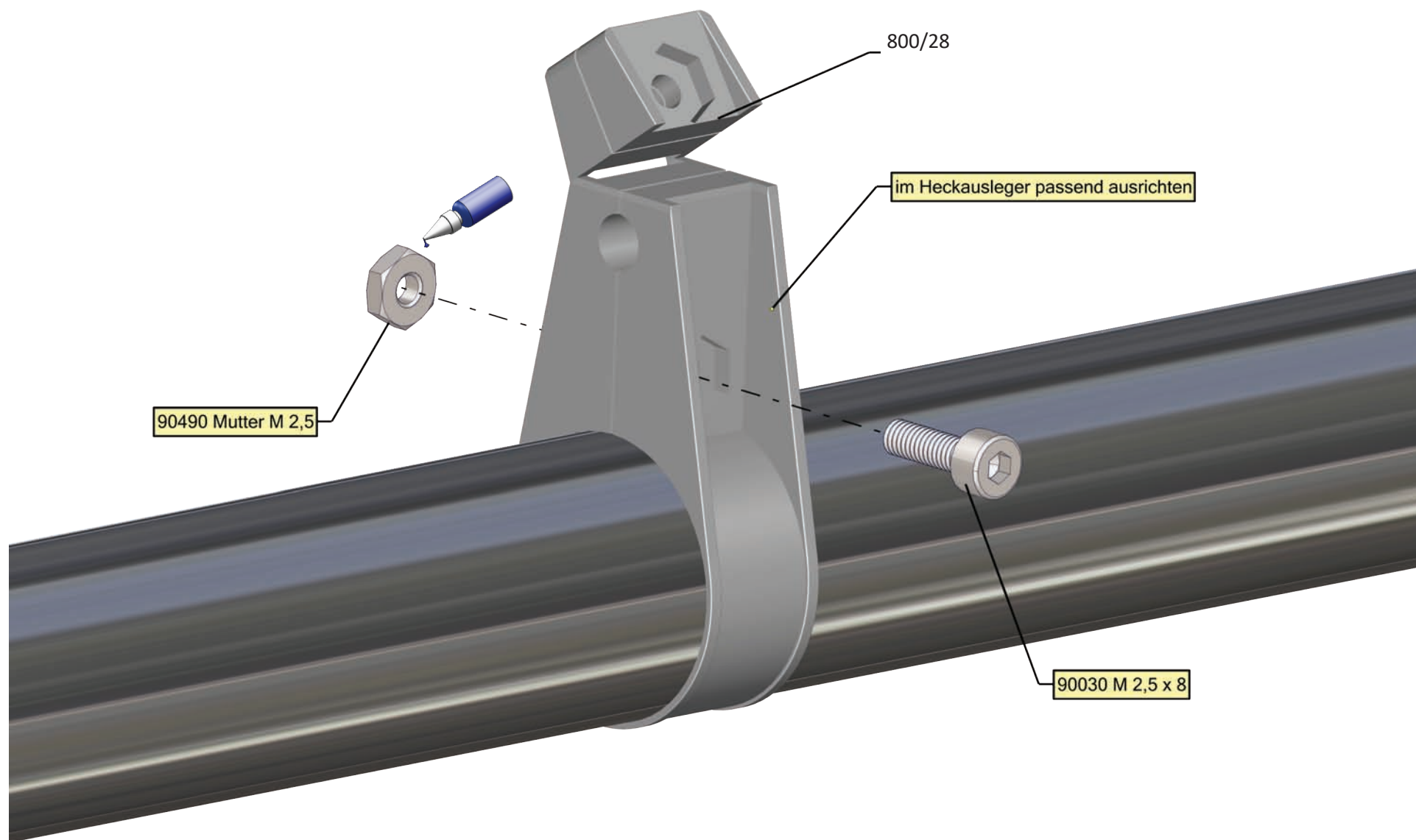

Ord.No.10/24
Schraubensicherung mittelfest
Thread-lock fluid medium-strength, 10ml

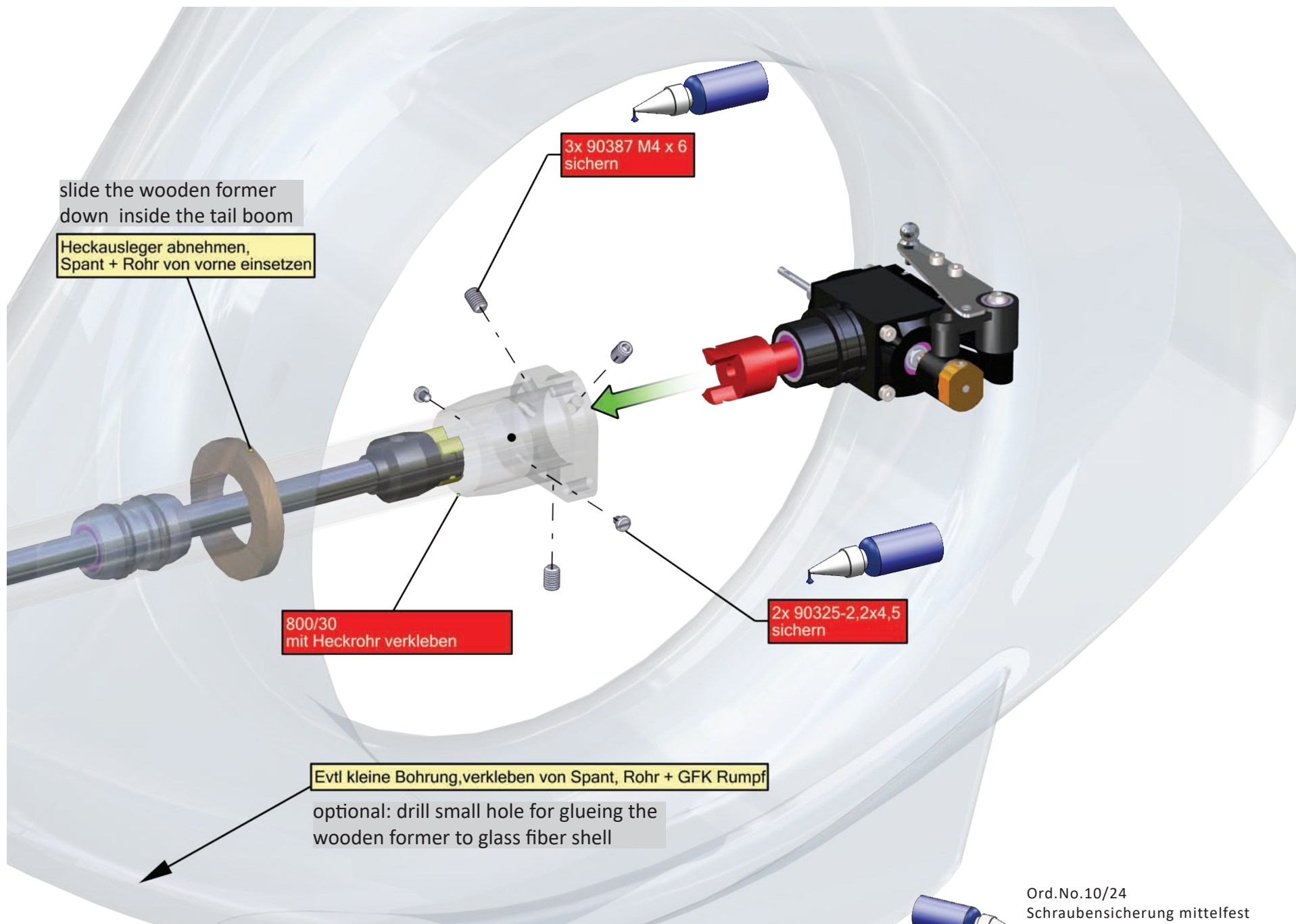

slide the wooden former
down inside the tail boom

Heckausleger abnehmen,
Spant + Rohr von vorne einsetzen

3x 90387 M4 x 6
sichern

800/30
mit Heckrohr verkleben

2x 90325-2,2x4,5
sichern

Evtl kleine Bohrung,verkleben von Spant, Rohr + GFK Rumpf

optional: drill small hole for glueing the
wooden former to glass fiber shell

Ord.No.10/24
Schraubensicherung mittelfest
Thread-lock fluid medium-strength, 10ml

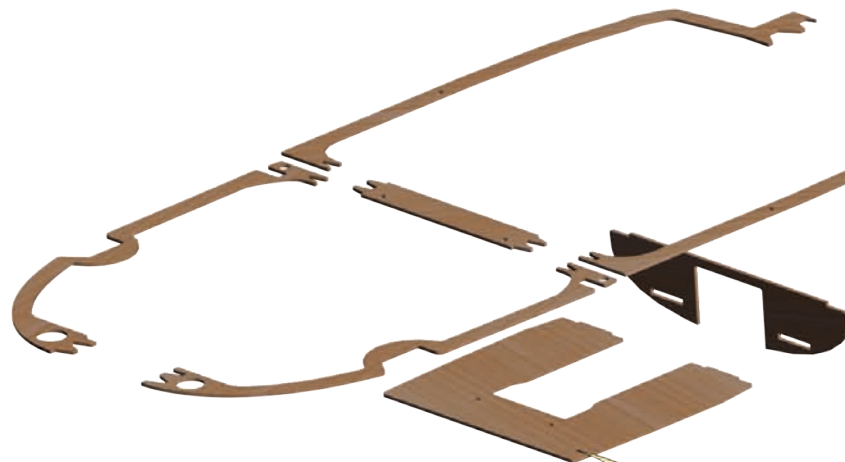
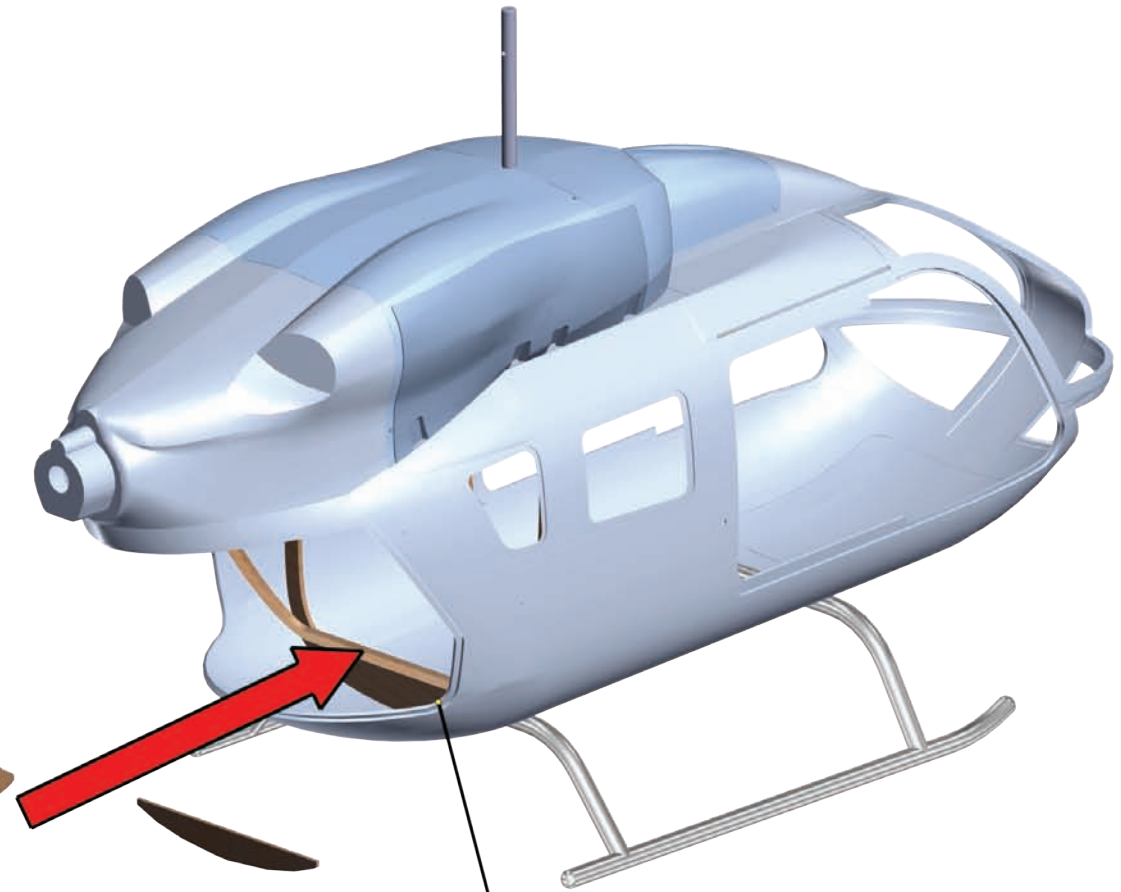
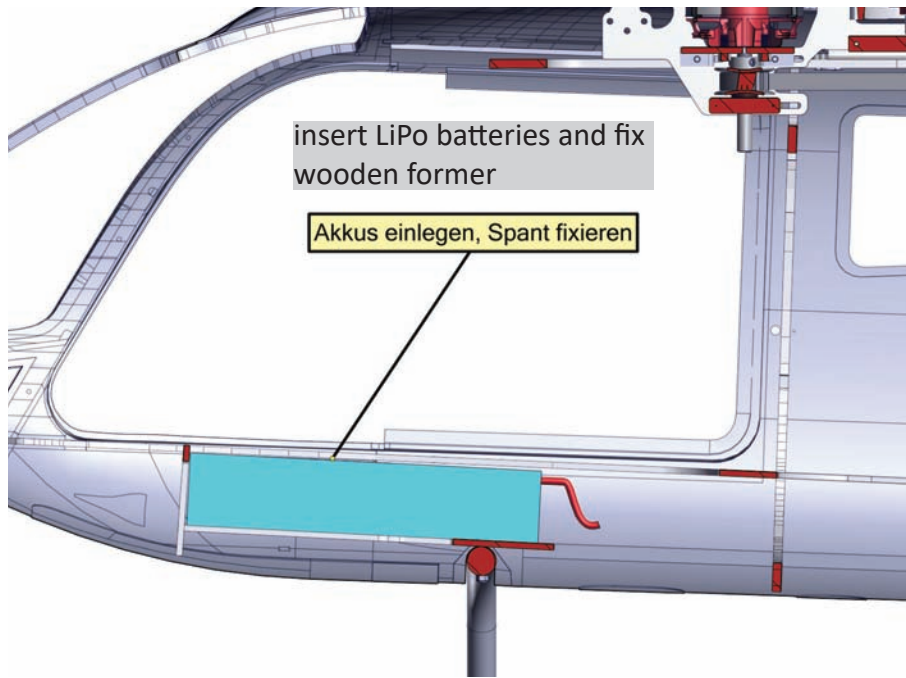

test fit wood parts in the fuselage

Spanten im Rumpf zusammen stecken

Ausschnitte für Heckklappen herstellen
cut out for rear doors



Ord.No. 11/29
Widia-Trennscheibe
inkl. Aufspanndorn

Ord.No: 11/29
Widia disc cutter

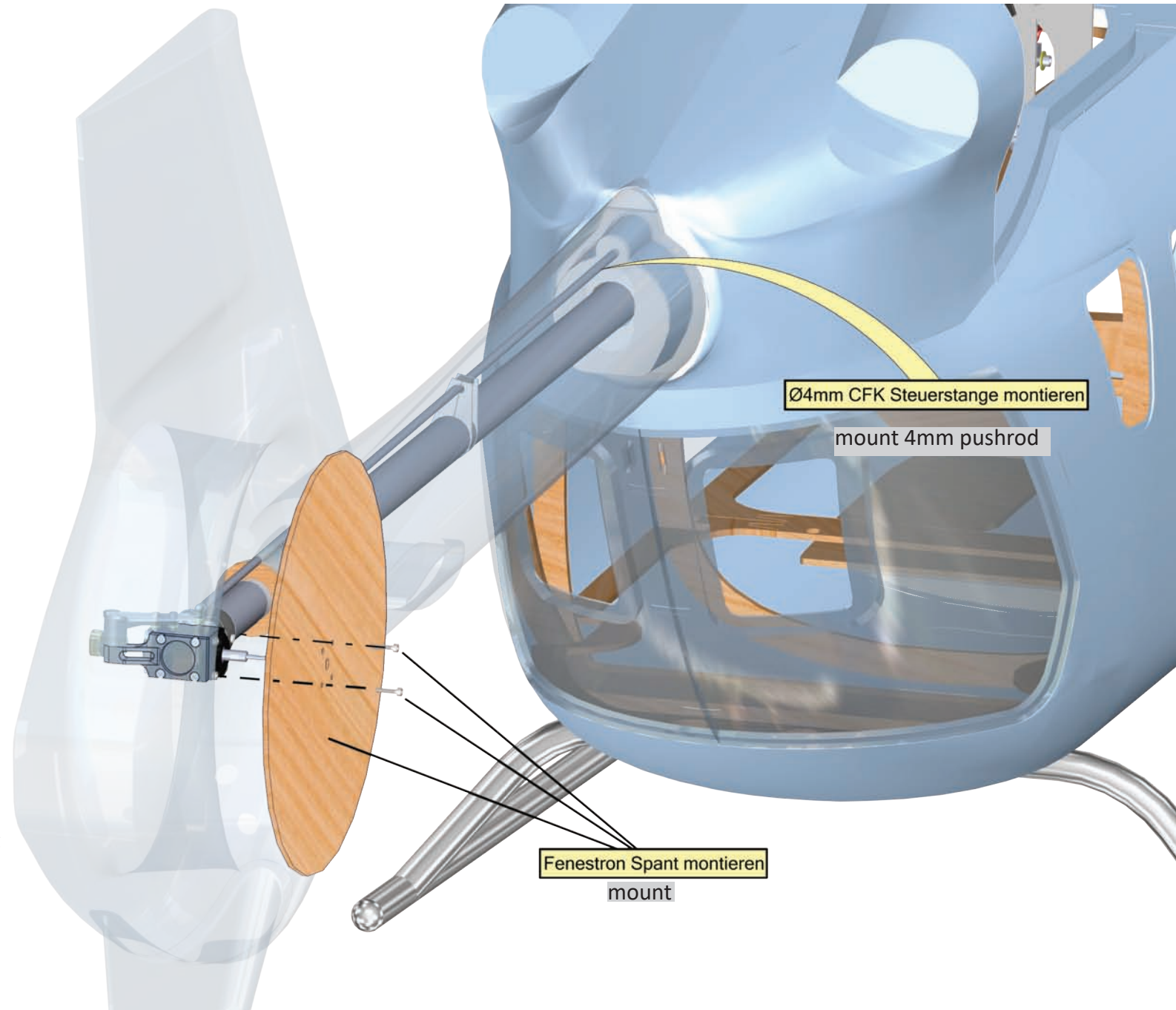

Ord.No. 10/123
Hochleistungs-Epoxydharz, 200 g
+ Härter, 80 g (40 Minuten)

Ord.No. 623
Poxan 30, 10 g

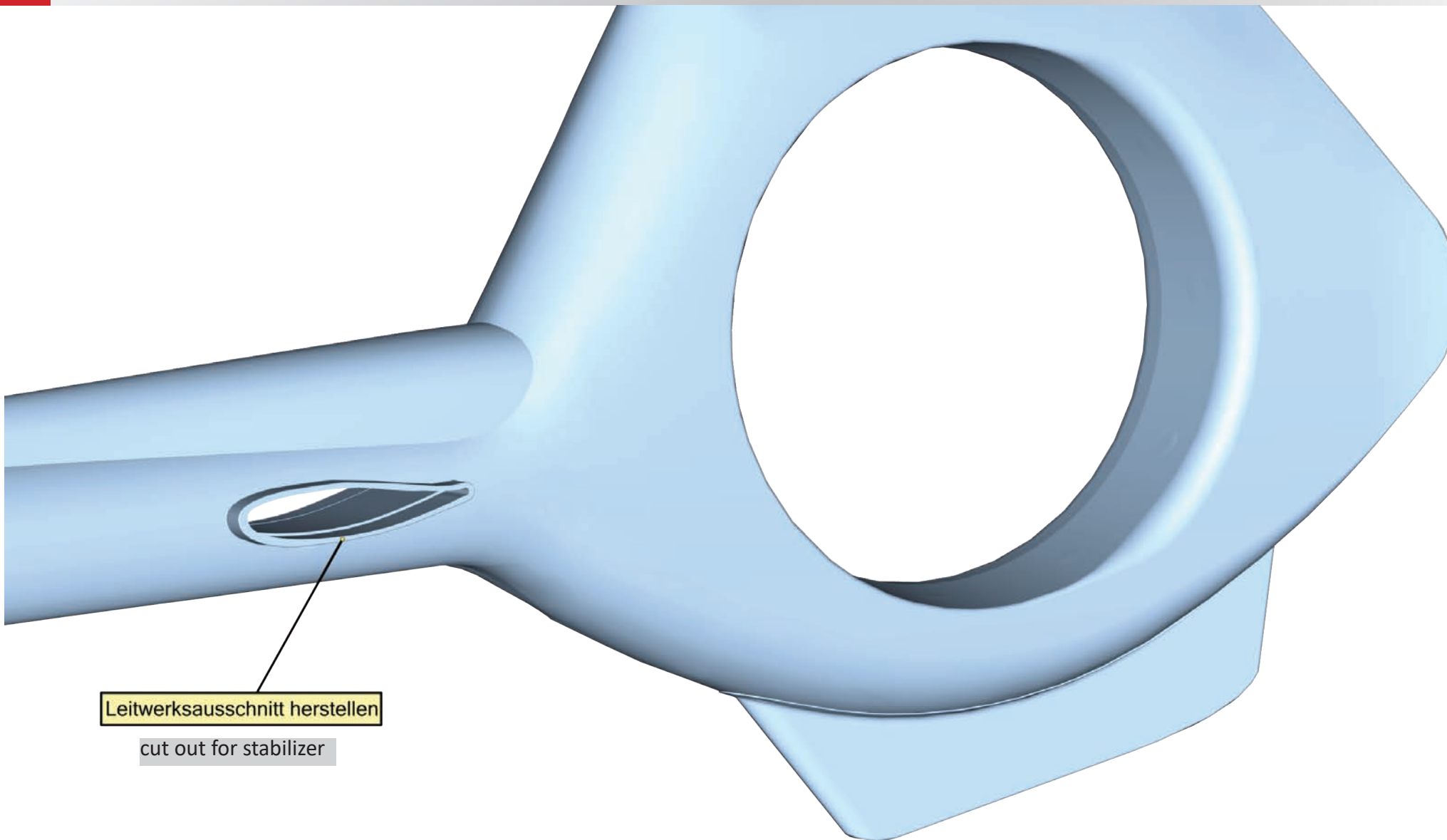

Leitwerksausschnitt herstellen

cut out for stabilizer



Ord.No. 11/29
Widia-Trennscheibe
inkl. Aufspanndorn

Ord.No: 11/29
Widia disc cutter

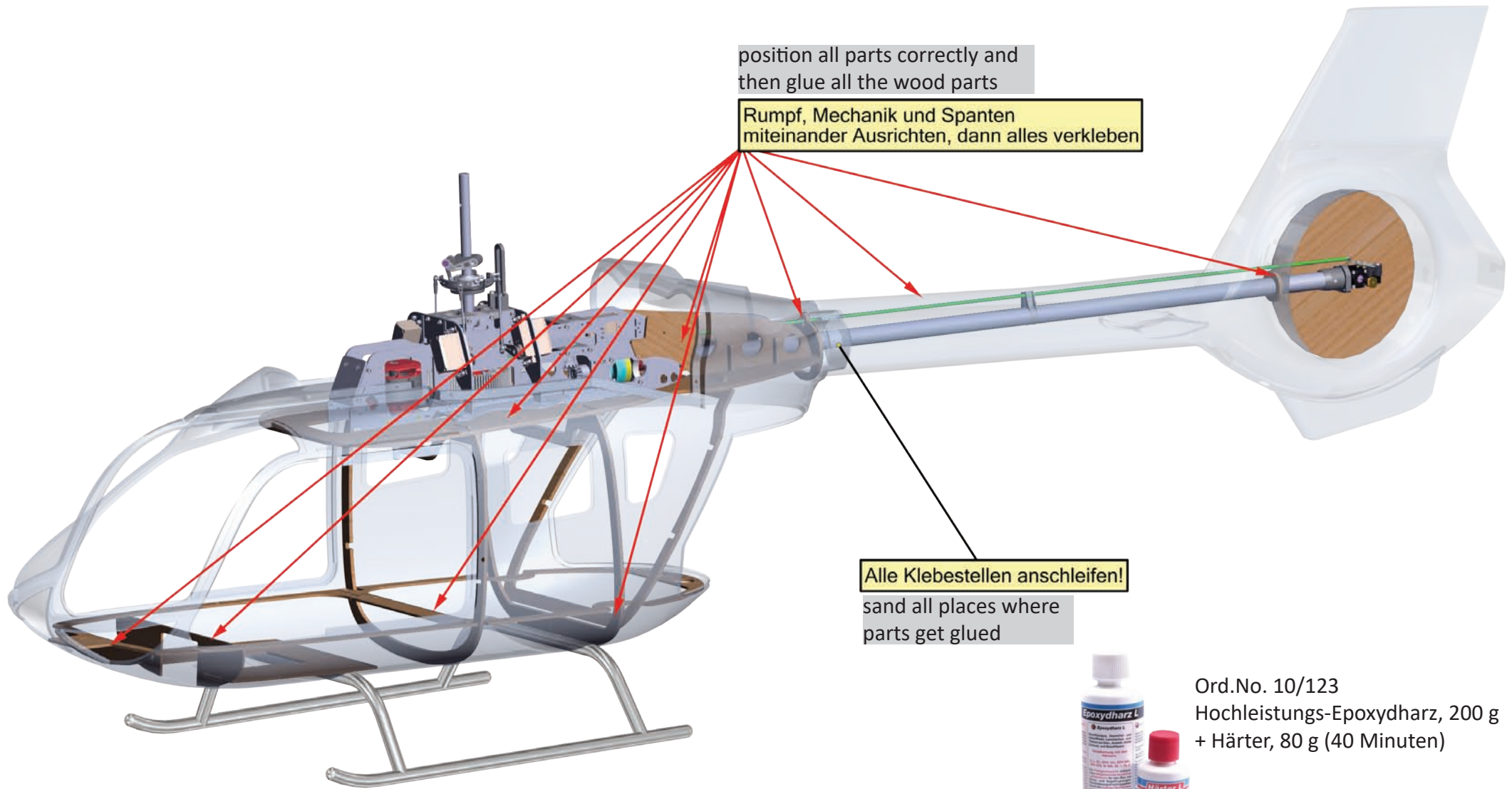

position all parts correctly and then glue all the wood parts

Rumpf, Mechanik und Spanten miteinander Ausrichten, dann alles verkleben

Alle Klebestellen anschleifen!
sand all places where parts get glued



Ord.No. 10/123
Hochleistungs-Epoxydharz, 200 g
+ Härter, 80 g (40 Minuten)

Ord.No. 623
Poxan 30, 10 g

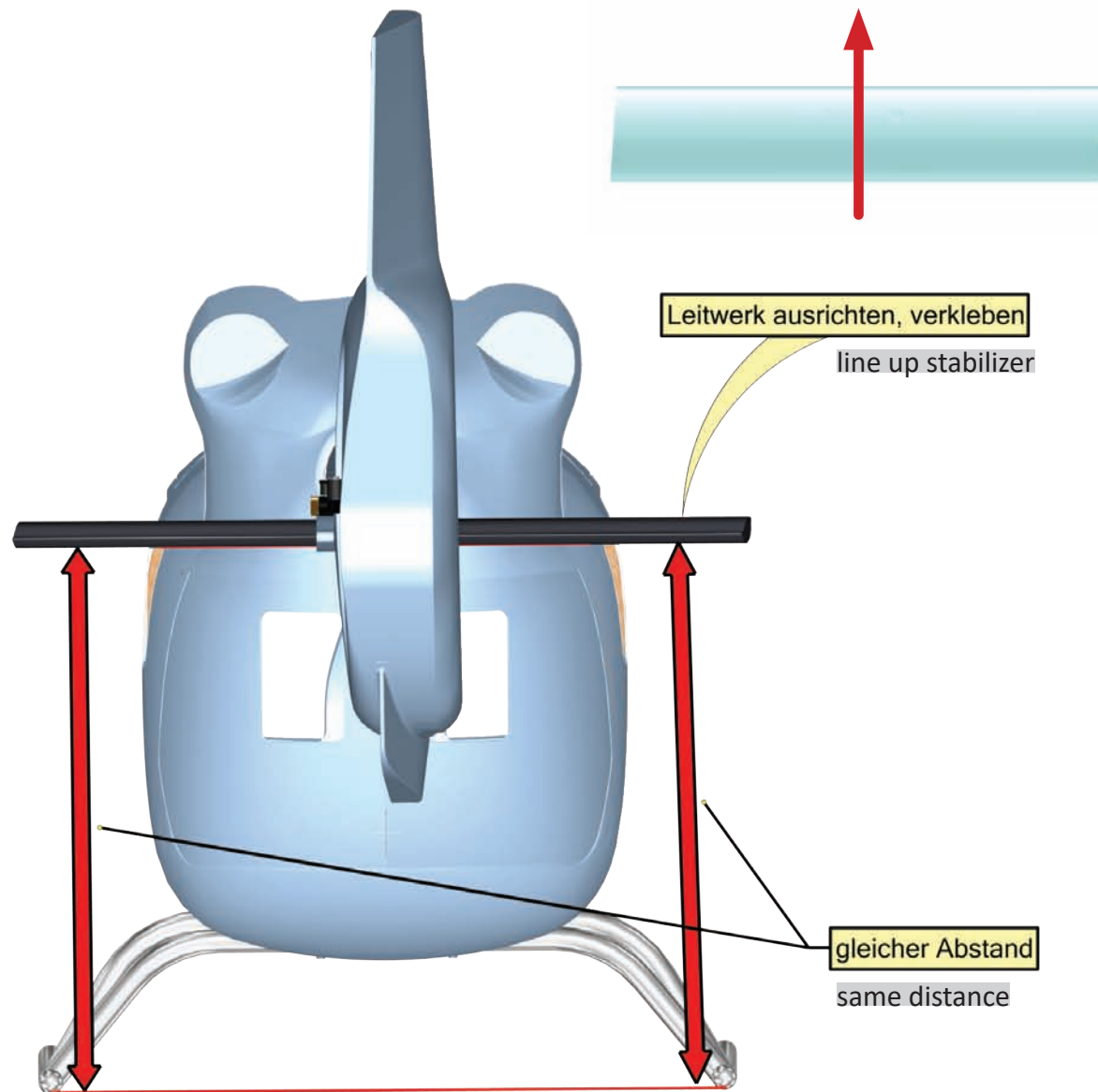
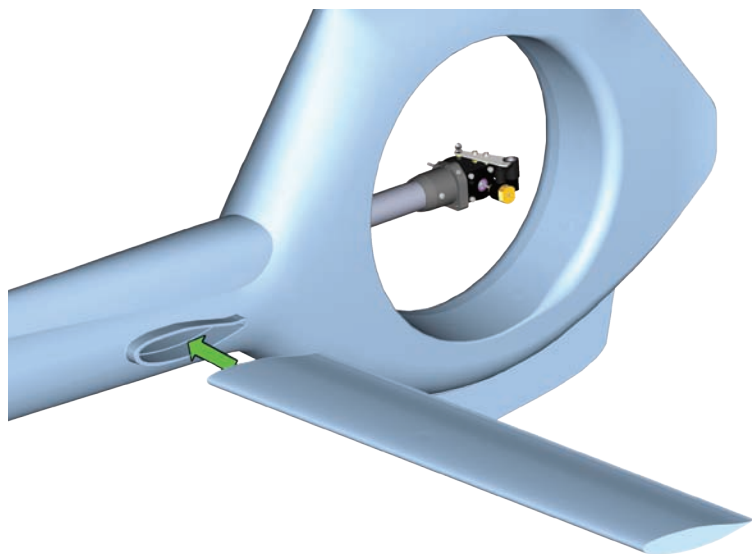

Ord.No. 10/123
Hochleistungs-Epoxydharz, 200 g
+ Härter, 80 g (40 Minuten)



Ord.No. 623
Poxan 30, 10 g

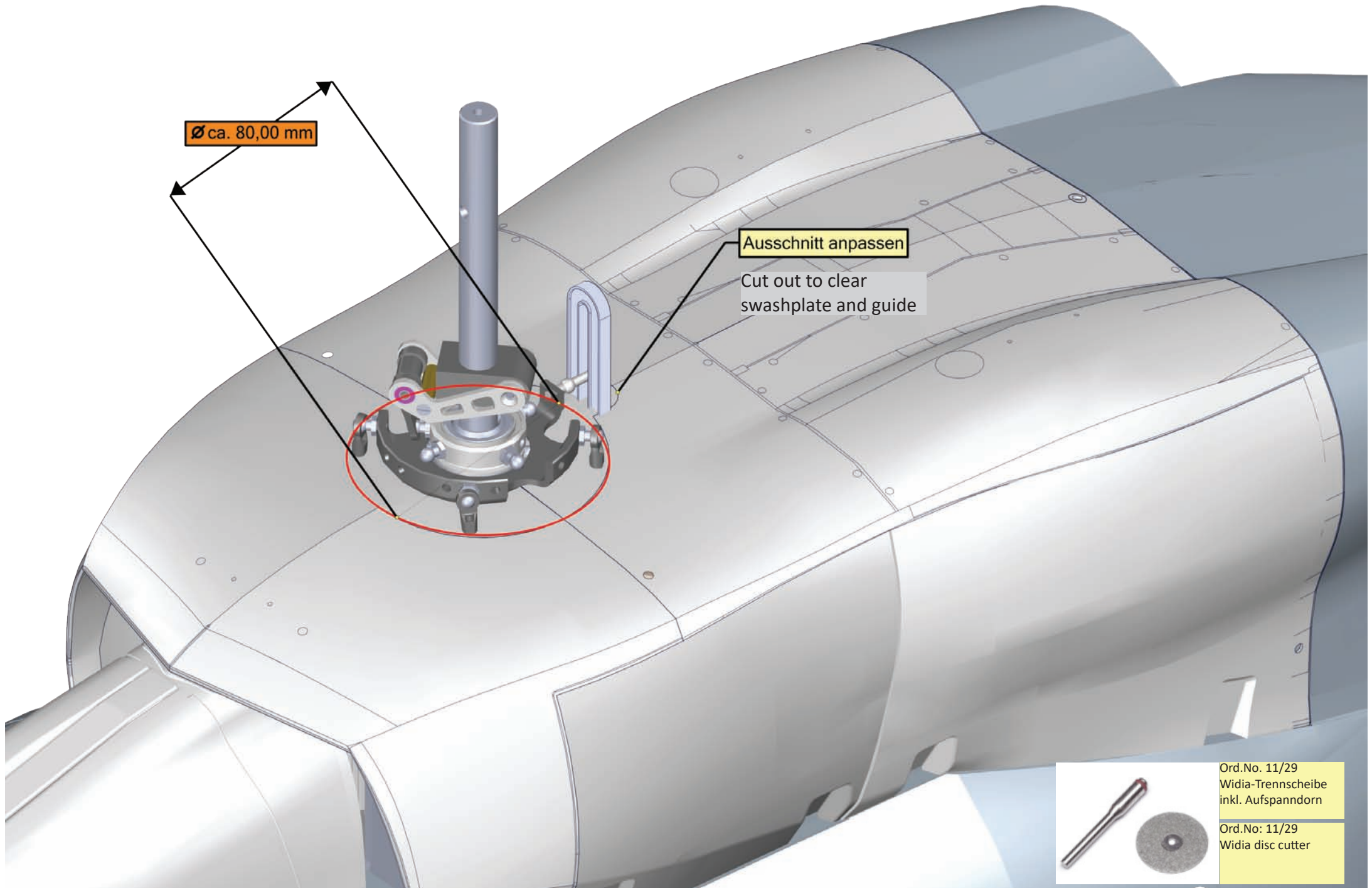

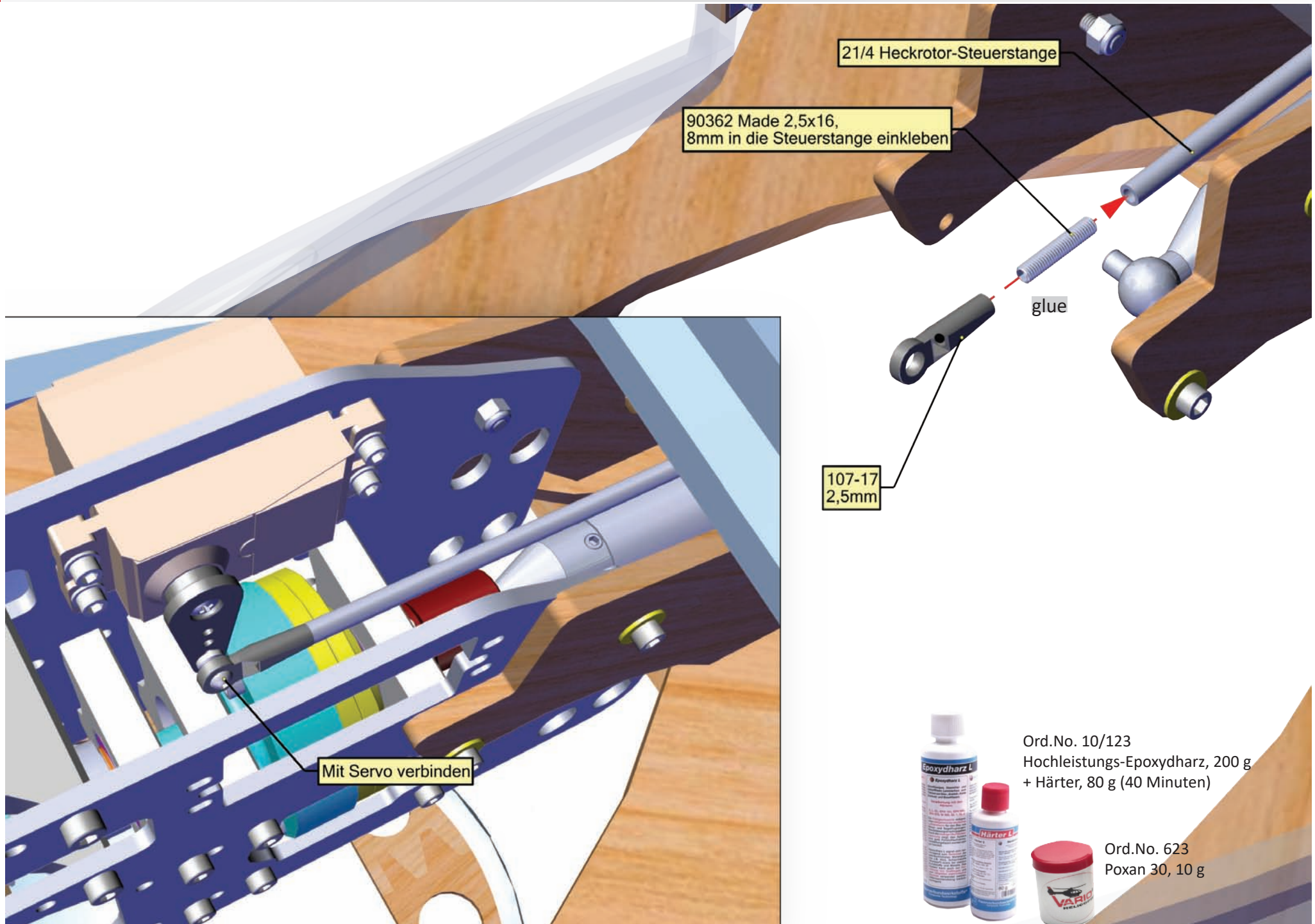

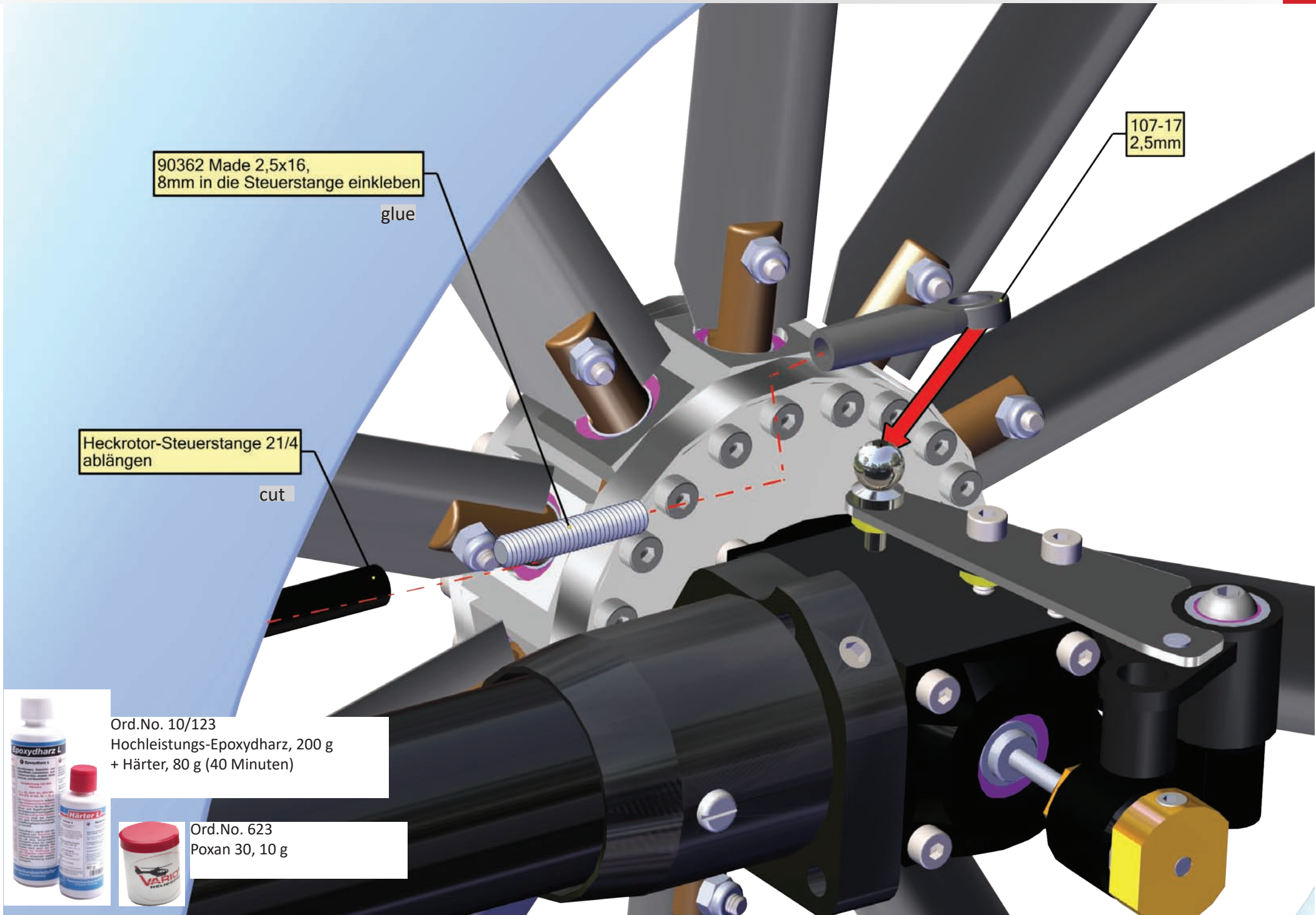

90362 Made 2,5x16,
8mm in die Steuerstange einkleben
glue

107-17
2,5mm

Heckrotor-Steuerstange 21/4
ablängen
cut



Ord.No. 10/123
Hochleistungs-Epoxydharz, 200 g
+ Härter, 80 g (40 Minuten)



Ord.No. 623
Poxan 30, 10 g

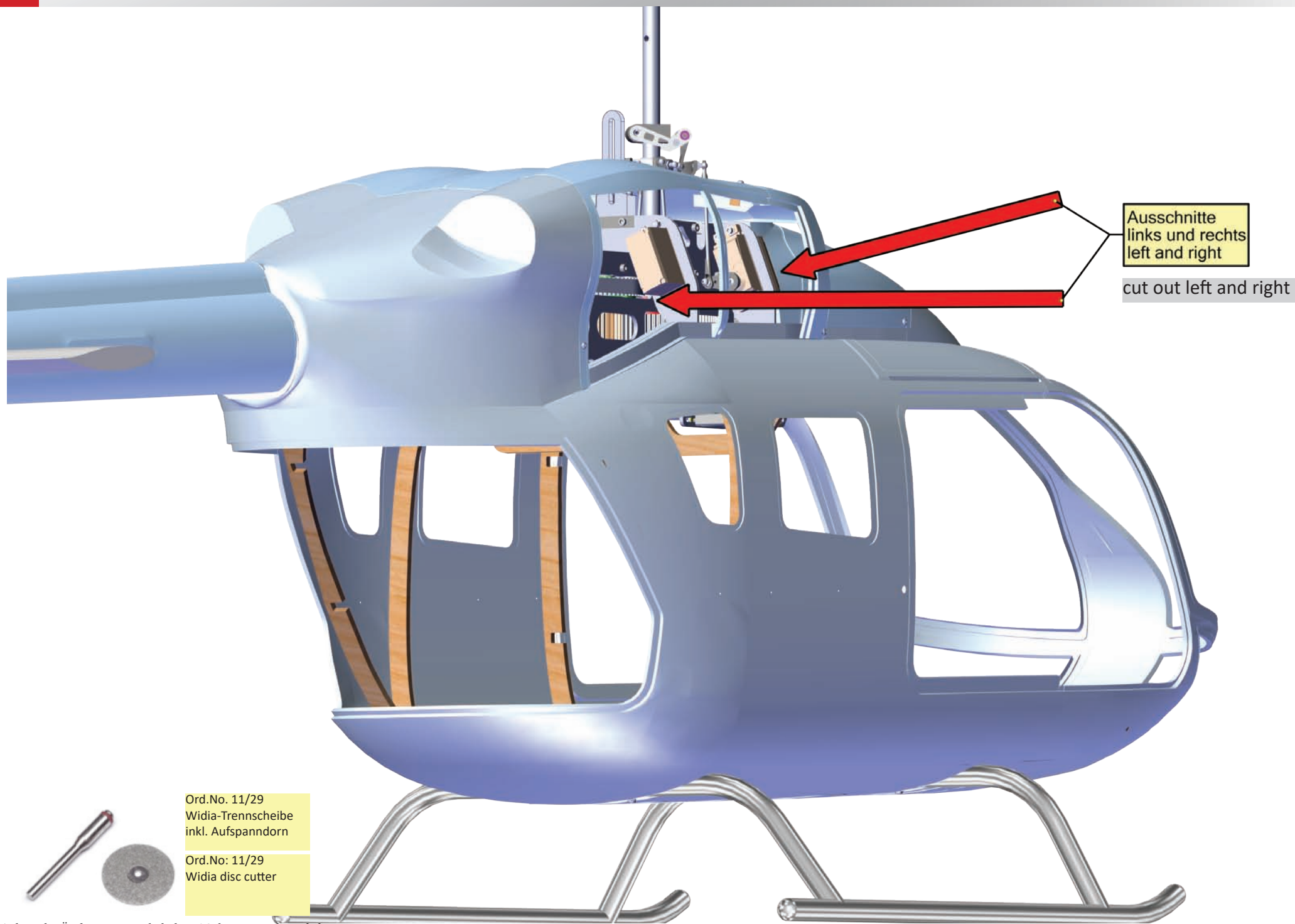

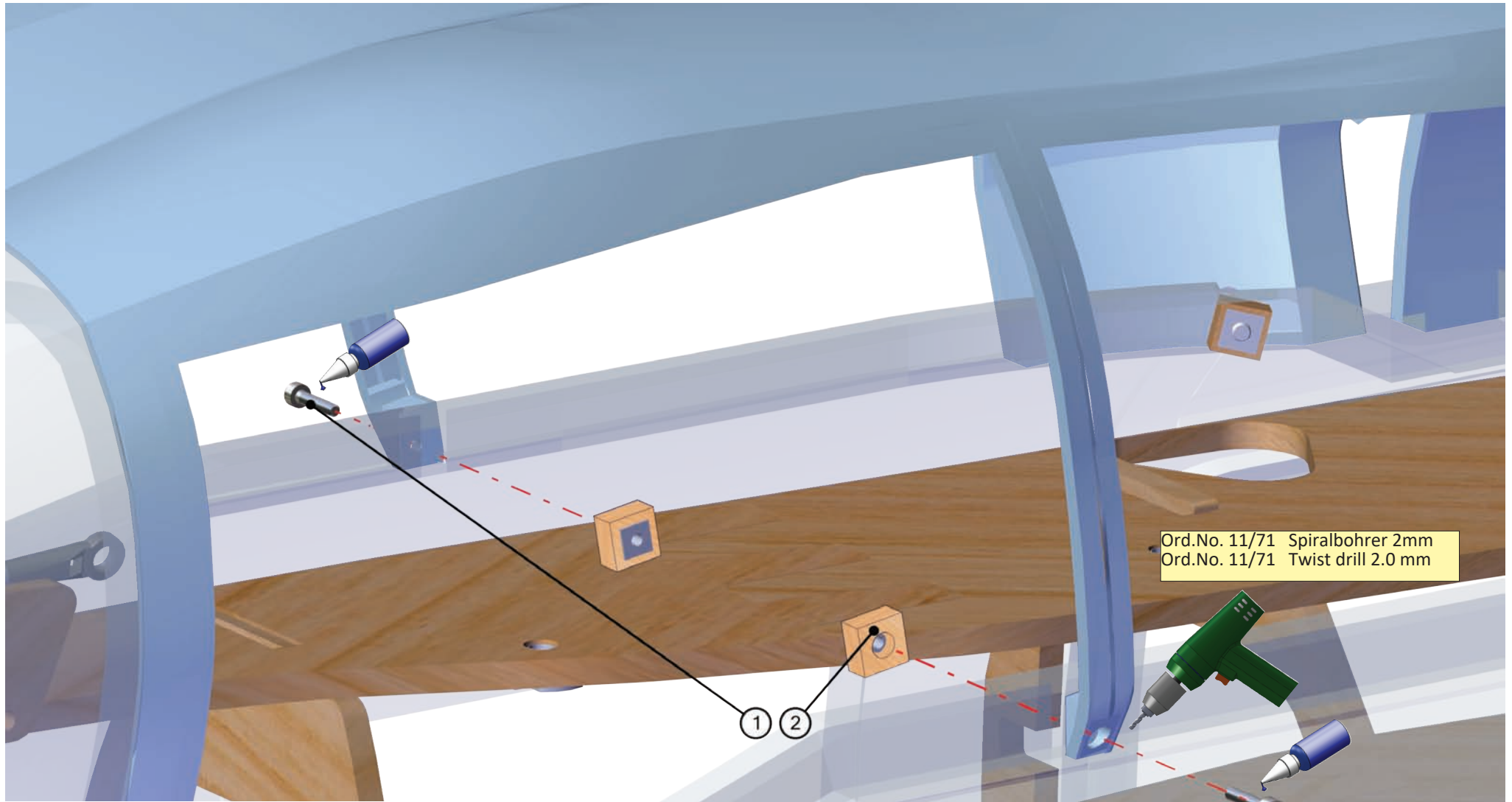

Ord.No. 11/71 Spiralbohrer 2mm
Ord.No. 11/71 Twist drill 2.0 mm



Ord.No. 10/123
Hochleistungs-Epoxydharz, 200 g
+ Härter, 80 g (40 Minuten)



Ord.No. 623
Poxan 30, 10 g

Pos.No.	Ord.No.	Menge
2	90510 Einschlagmutter M2	2
1	90020 M2 x 10	2

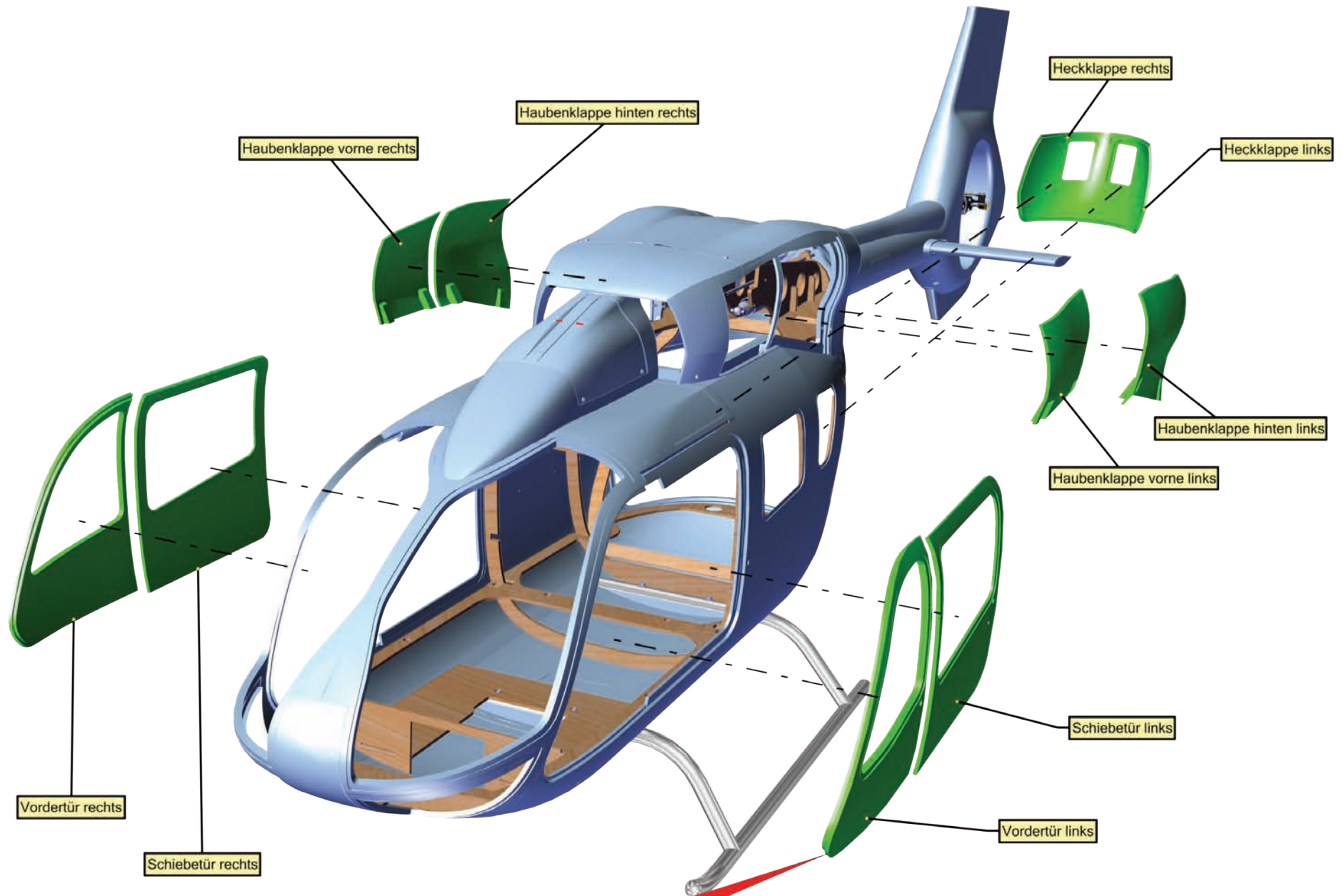

Türen und Klappen optional beweglich gestalten
mit dem Tür.Beschlagsatz Ord.No.147/5

for operational doors use fitting set 147/5



64 x 90222
1,6 x 6mm

Scheiben ausschneiden,
anpassen und anschrauben

cut to size and fit the windows



Ord.No. 11/74 Spiralbohrer 1mm
Ord.No. 11/74 Twist drill 1.0 mm

alle Scheiben mit 1mm vorbohren

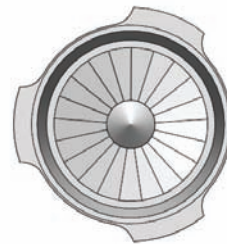
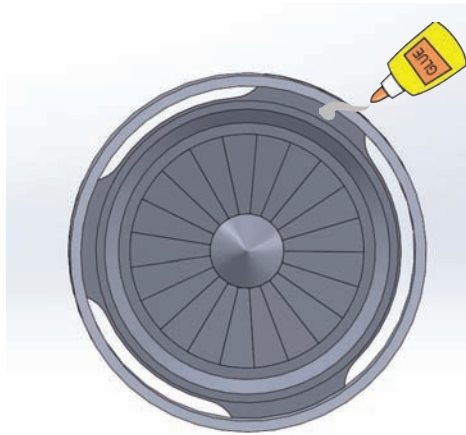

Ord.No. 20/35

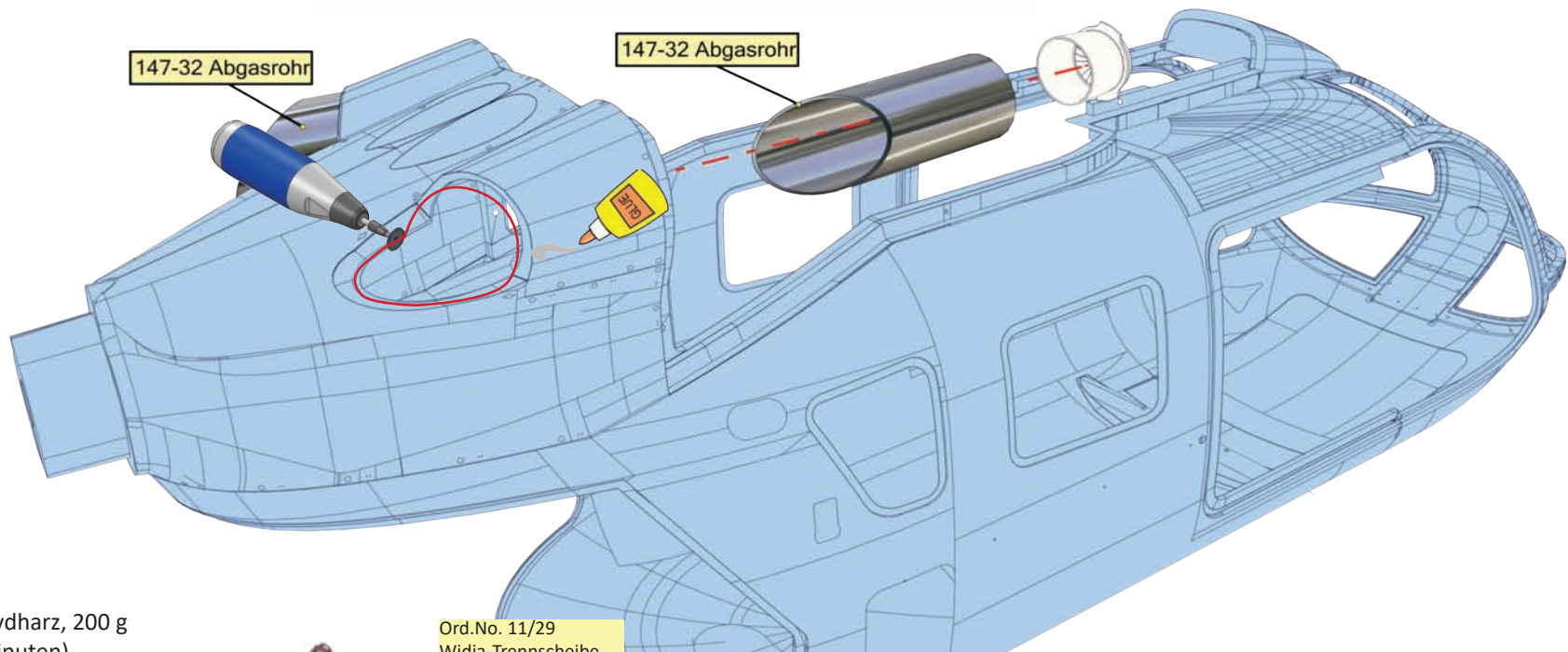
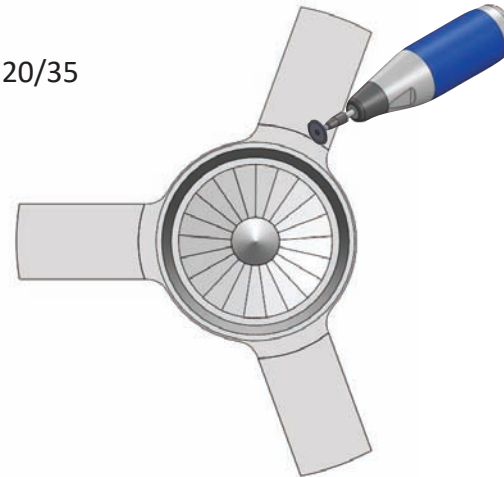

Ord.No. 10/123
Hochleistungs-Epoxydharz, 200 g
+ Härter, 80 g (40 Minuten)



Ord.No. 623
Poxan 30, 10 g



Ord.No. 11/29
Widia-Trennscheibe
inkl. Aufspanndorn

Ord.No: 11/29
Widia disc cutter

