

Radio control model / Flugmodell

# P-47B/D THUNDERBOLT



VQA142DC

VQ No: VQA142DC  
VQ No: VQA142DT  
VQ No: VQA142BT

ALL Balsa, PLYWOOD CONSTRUCTION AND ALMOST READY TO FLY

## Instruction manual / Montageanleitung

### SPECIFICATIONS

Wingspan:.....1480mm  
Length:.....1215mm  
Electric Motor:.....See next pager  
Glow Engine:......46 2-T / .70 4-T  
RTF Weight: 3.1Kg (will vary with equipment use)  
Radio:.....7 Channel / 7 Servos  
Function: Ailerons-Elevator-Rudder-Throttle Flaps.

### TECHNISCHE DATEN

Spannweite:.....1480mm  
Länge:.....1215mm  
Elektroantrieb.....(siehe nächste Seite)  
Verbrennerantrieb:.....7.45cc - 11.5cc  
Fluggewicht:.....3.1Kg  
Fernsteuerung.....7 Kanal / 7 Servos



**WARNING!** This radio controlled model is NOT a toy. If modified or flown carelessly it could go out of control and cause serious human injury or property damage. Before flying your airplane, ensure the air field is spacious enough. Always fly it outdoors in safe areas and seek professional advice if you are unexperienced.

**ACHTUNG!** Dieses ferngesteuerte Modell ist KEIN Spielzeug! Es ist für fortgeschrittene Modellflugpiloten bestimmt, die ausreichende Erfahrung im Umgang mit derartigen Modellen besitzen. Bei unsachgemäßer Verwendung kann hoher Personen- und/oder Sachschaden entstehen. Fragen Sie in einem Modellbauverein in Ihrer Nähe um professionelle Unterstützung, wenn Sie Hilfe im Bau und Betrieb benötigen. Der Zusammenbau dieses Modells ist durch die vielen Abbildungen selbsterklärend und ist für fortgeschrittene, erfahrene Modellbauer bestimmt.

## REQUIRED FOR OPERATION (Purchase separately)

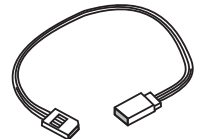
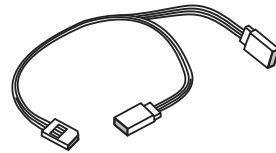
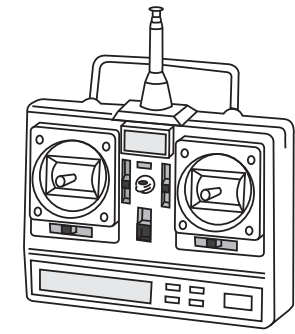

Flap: "Y" x2 pcs  
Aileron: "Y"x1pcs

Aileron: 50cmx2 pcs  
Flap: 30cmx2 pcs  
Rx battery pack: 20cmx1 pcs

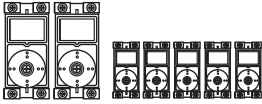

Standard Mini

Minimum 7 channel radio  
Elevator : 1 standard servo  
Rudder: 1 standard servo  
Aileron: 2 mini servo  
Flaps: 2 mini servo  
Throttle: 1 mini servo (for glow engine only)

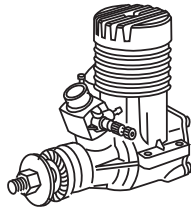

.46 ~ .50 - 2 cycle

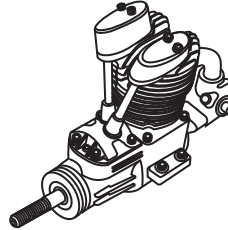

.72 ~ .82 - 4 cycle

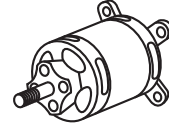

700-800W Brushless Motor



Silicone tube

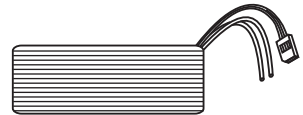

5 cell 4500mAh LiPo battery

## GLUE (Purchase separately)



Silicon sealer

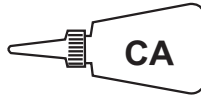

Cyanoacrylate Glue (thin type)



Epoxy Glue  
(30 minute type)

## TOLLS REQUIRED (Purchase separately)

Hobby knife 

Phillip screw driver 

Hex Wrench 

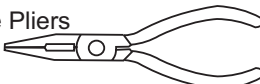
Needle nose Pliers 

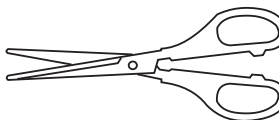
Scissors 

Awl 

Sander 

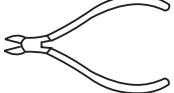
Wire Cutters 

Masking tape - Straight Edged Ruler - Pen or pencil - Drill and Assorted Drill Bits

If exposed to direct sunlight and/or heat, wrinkles can appear. Storing the model in a cool place will let the wrinkles disappear. Otherwise, remove wrinkles in covering film with a hair dryer, starting with low temperature. You can fix the corners by using a hot iron.

Bei Sonneneinstrahlung und/oder Wärme kann die Folie erschlaffen bzw. Falten entstehen. Verwenden Sie ein Warmluftgebläse (Haartrockner) um evtl. Falten aus der Folie zu bekommen. Die Kanten können Sie mit einem Bügeleisen behandeln. Nicht zuviel Hitze anwenden !

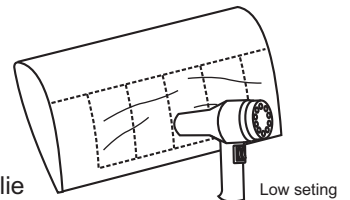

Low setting

Symbols used throughout this instruction manual, comprise:

 Drill holes using the stated size of drill (in this case 1.5 mm)	 Take particular care here	 Hatched-in areas: remove covering film carefully	 Check during assembly that these parts move freely, without binding
 Use epoxy glue	 Apply cyano glue	 Assemble left and right sides the same way.	 Not included. These parts must be purchased separately

 Löcher bohren mit dem angegebenen Bohrer (hier 1,5 mm)	 Hier besonders aufpassen	 Schraffierte Stellen, Bespannfolie vorsichtig entfernen	 Während des Zusammenbaus immer prüfen, ob sich die Teile auch reibungslos bewegen lassen
 Epoxy-Klebstoff verwenden	 Sekundenkleber auftragen	 Linke und rechte Seite wird gleichermaßen zusammengebaut	 Nicht enthalten. Teile müssen separat gekauft werden.

Read through the manual before you begin, so you will have an overall idea of what to do.

## CONVERSION TABLE

1.0mm = 3/64"	3.0mm = 1/8"	10mm = 13/32"	25mm = 1"
1.5mm = 1/16"	4.0mm = 5/32"	12mm = 15/32"	30mm = 1-3/16"
2.0mm = 5/64"	5.0mm = 13/64"	15mm = 19/32"	45mm = 1-51/64"
2.5mm = 3/32"	6.0mm = 15/64"	20mm = 51/64"	

# P-47 THUNDERBOLT 1- ENGINE MOUNT

Push left (or right) the magnetic fuel tank hatch and full it out of the fuselage.

Cut the wood along the line as shown (1A) in case of 4T engine using

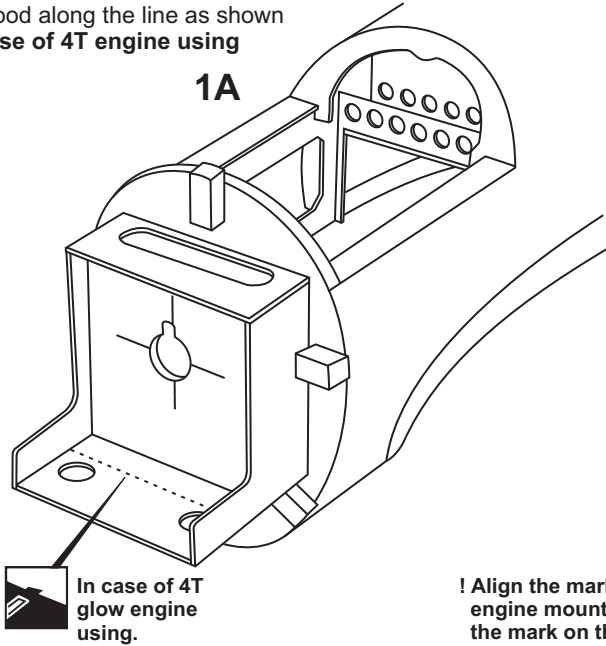

Attach the engine mount beams onto the fire-wall so the distance between of two engine mount beams is "A", and B=B' as show. Secure the engine mount beams onto the fire-wall with litter CA glue (1B)

**! Align the mark on both engine mount beams with the mark on the fuselage**

Using a pencil or felt tipped pen, mark the fire wall where the four holes are to be drilled(1B))

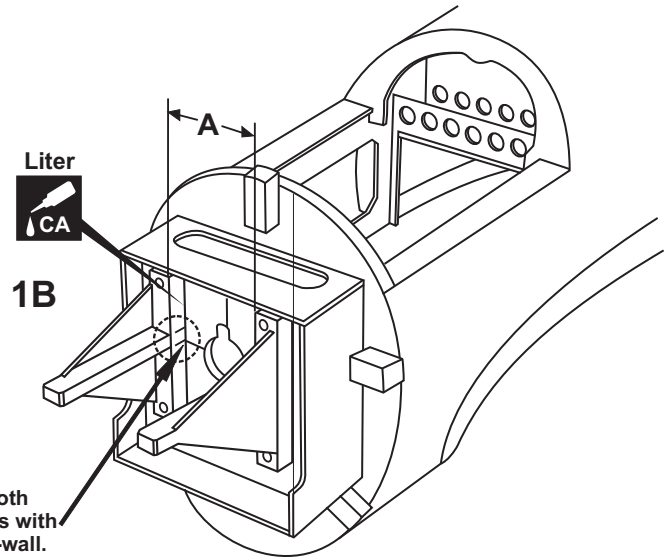

**! Align the mark on both engine mount beams with the mark on the fire-wall.**

## 1C

Carefully remove the engine mount beams and drill a 6mm hole through the fire-wall at each of the four marks made above (1C)

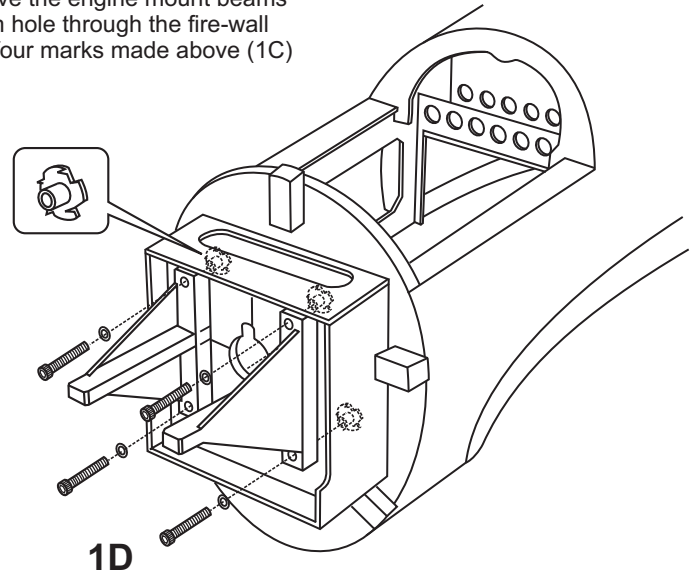
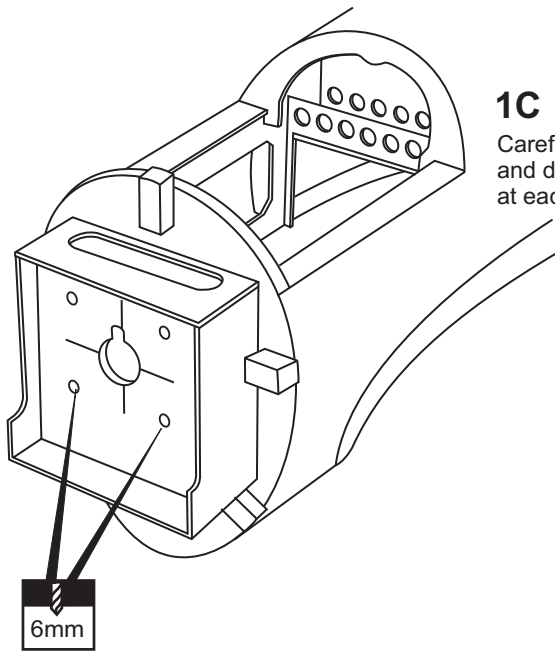



## 1D

Insert the blind-nut onto each of the four holes make above (1D).

Reposition the engine mount beams on to the fire-wall and secure them with four 4x25mm screw (1D)

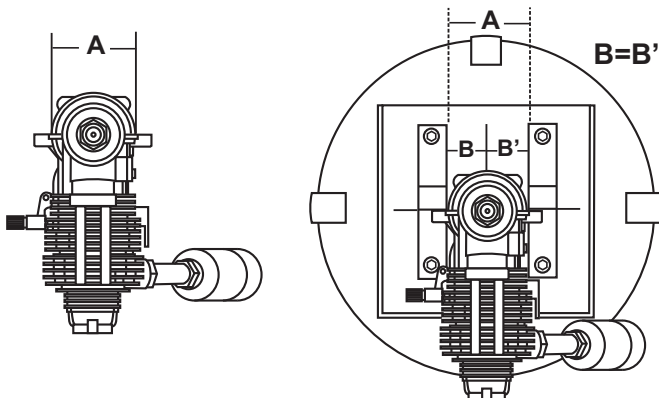
FRONT-VIEW



4x25mm screw - washer		
	.....	4
Blind-nut		
	.....	4

# P-47 THUNDERBOLT 2- ENGINE

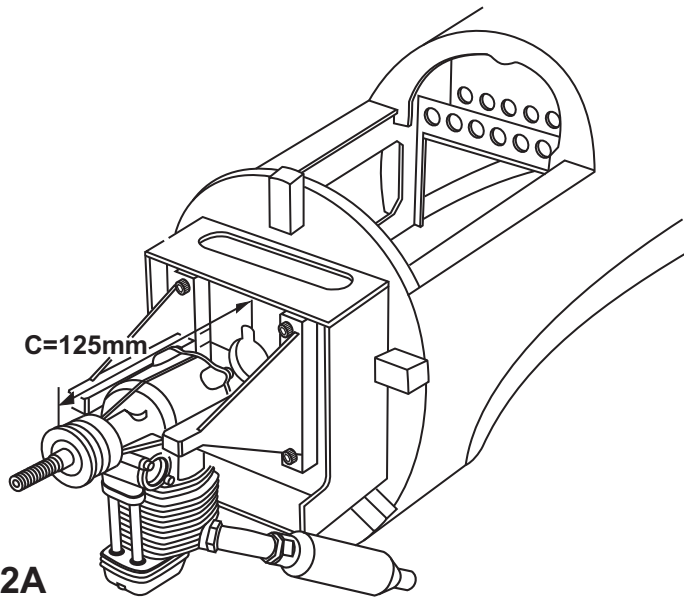

**2A**

Position the engine to the engine mounts so the distance from the prop hub to the fire-wall is 125mm.  
Mark the engine mounting plate where the four holes are to be drilled (2A)

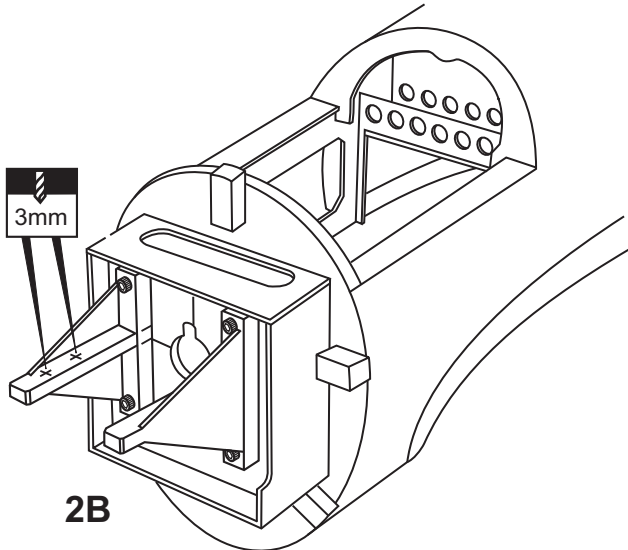

**2B**

Remove the engine and drill a 3mm holes through the beam at each of the four marks made above (2B)  
Marking sure that you drill the hole perpendicular to the beam of the engine mount.

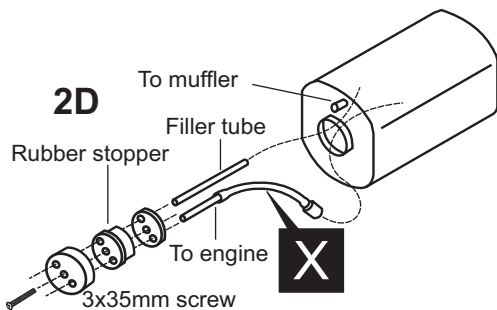

**2D**

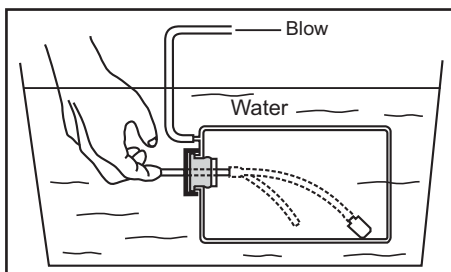

**2E**

Checking for leaks - block the vents and blow into the feed - if in doubt submersing the tank in a blow of water will show up any problems.

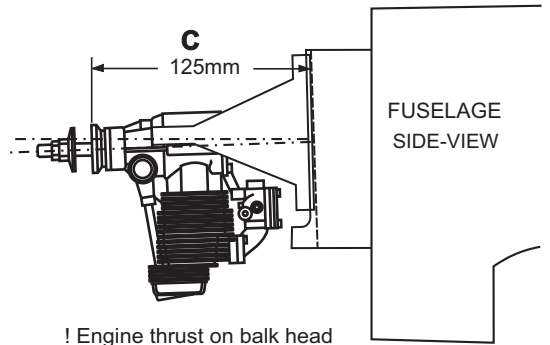

! Engine thrust on balk head is already adjust at factory

3x25mm screw	.....4
Washer	.....4

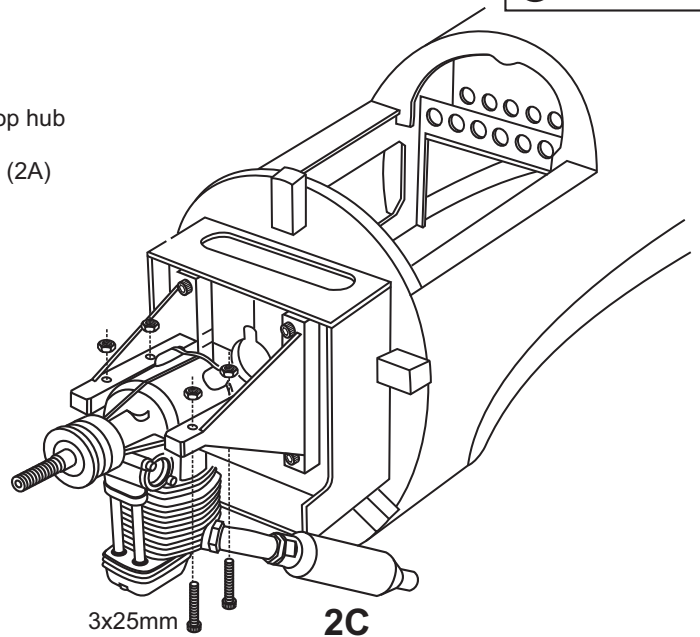

3x25mm

**2C**

Reposition the engine on the engine mount beams, aligning it with the holes. Secure the engine to the engine mount using four 3x25mm screws (2C)

Note: Apply Silicon sealer to each of the 3x25mm screw and nut.

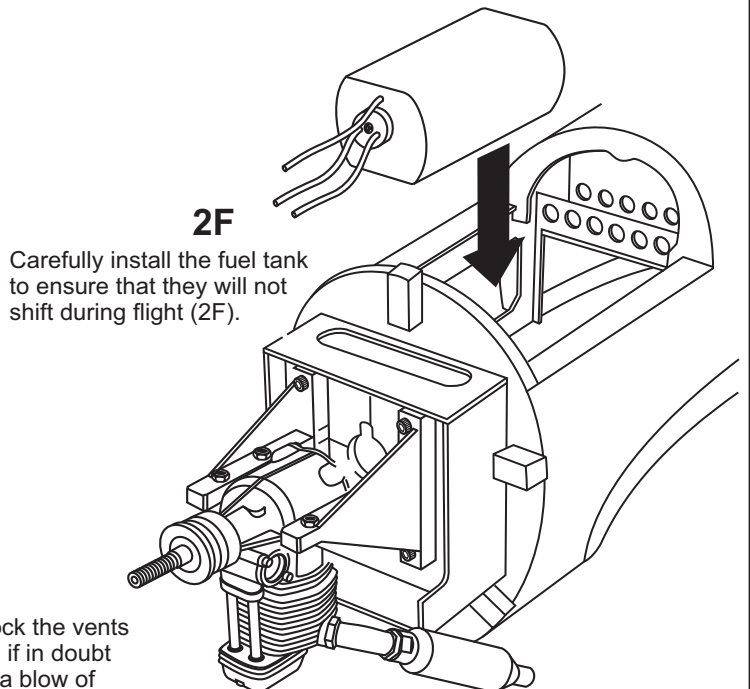

**2F**

Carefully install the fuel tank to ensure that they will not shift during flight (2F).

# P-47 THUNDERBOLT 3- ELECTRIC MOTOR

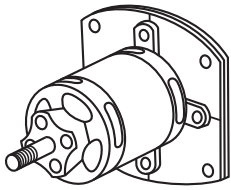

Using an aluminum motor mounting plate as a template, mark the plywood motor mounting plate where the four holes are to be drilled.

**3A**

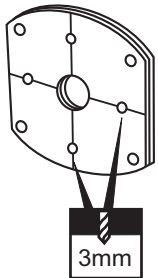

Remove the aluminum motor mounting plate and drill a 1/8" (3mm) hole through the plywood at each of the four marks marked.

**3B**

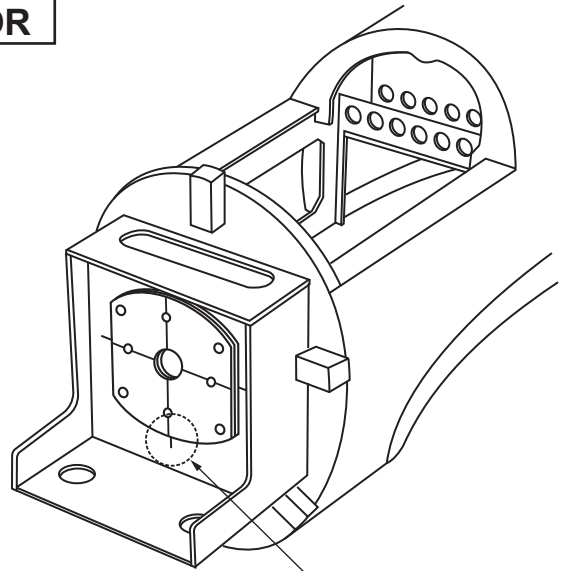

**! Align the mark on wooden motor mounting plate with the mark on the fire-wall.**

**3C**

Using a wooden motor mounting plate as a template, mark the fire-wall where the four holes are to be drilled (3C).

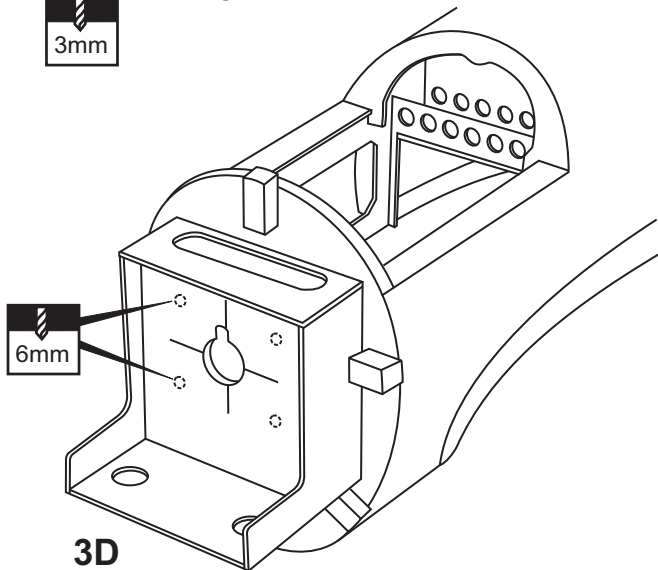

**3D**

Remove the wooden motor mounting plate and drill a 6mm hole through the fire-wall at each of the four marks marked (3D).

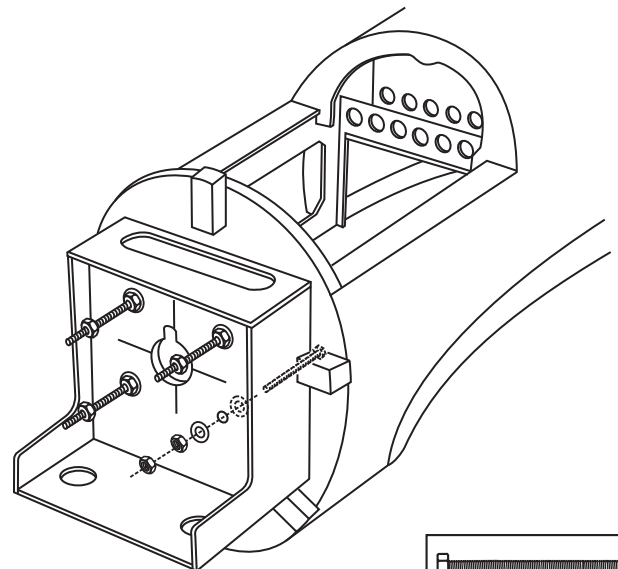

**3E**

Attach the four 5x70mm bolts and nuts to the fire-wall as shown (3E).

	6x100mm bolt....4
	6mm nut.....12
	6mm washer...16

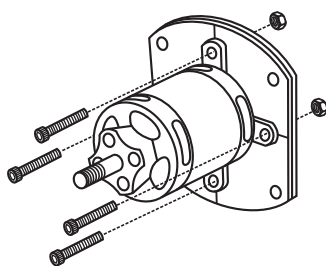

**3F**

Secure the Motor to the wooden motor mounting plate using the four 3mm bolts.

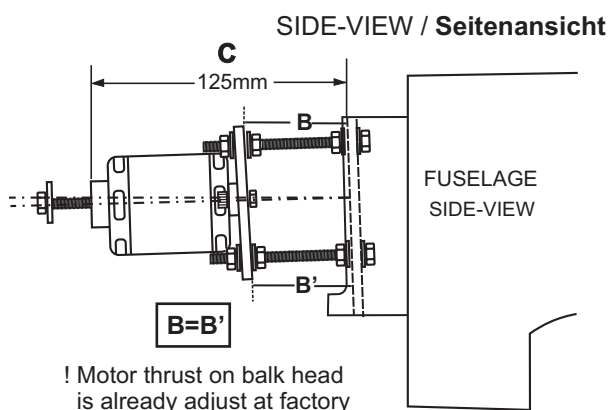

**3G**

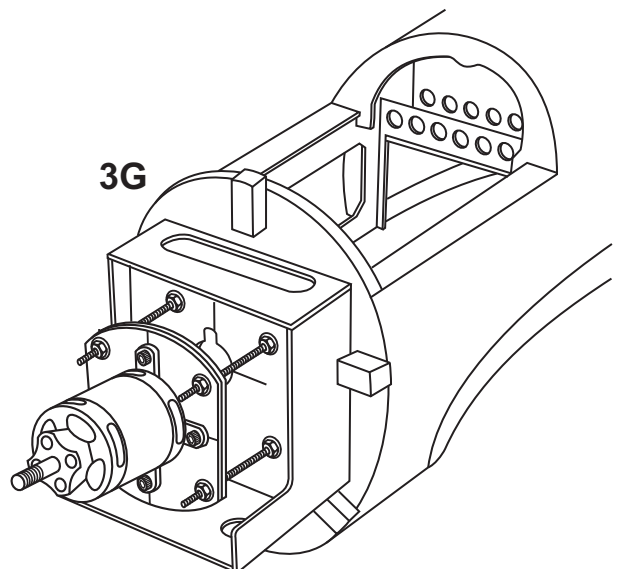

# P-47 THUNDERBOLT 4- WING: SERVO AND LINKAGES

Secure the plastic control horn in place using the thin CA glue.

Thin CA

Cut away only the covering

- Plastic control horn .....2 set
- Plastic control horn .....2 set
- 2x20mm screw .....4

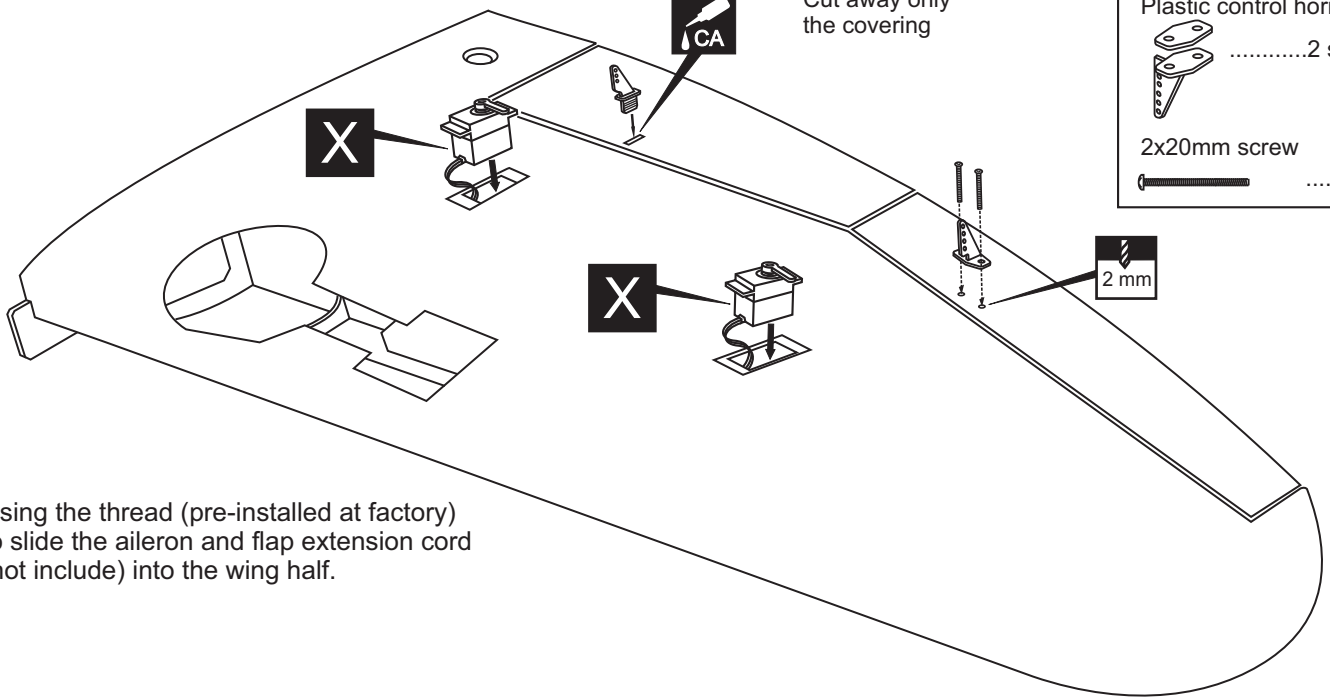

Using the thread (pre-installed at factory) to slide the aileron and flap extension cord (not include) into the wing half.

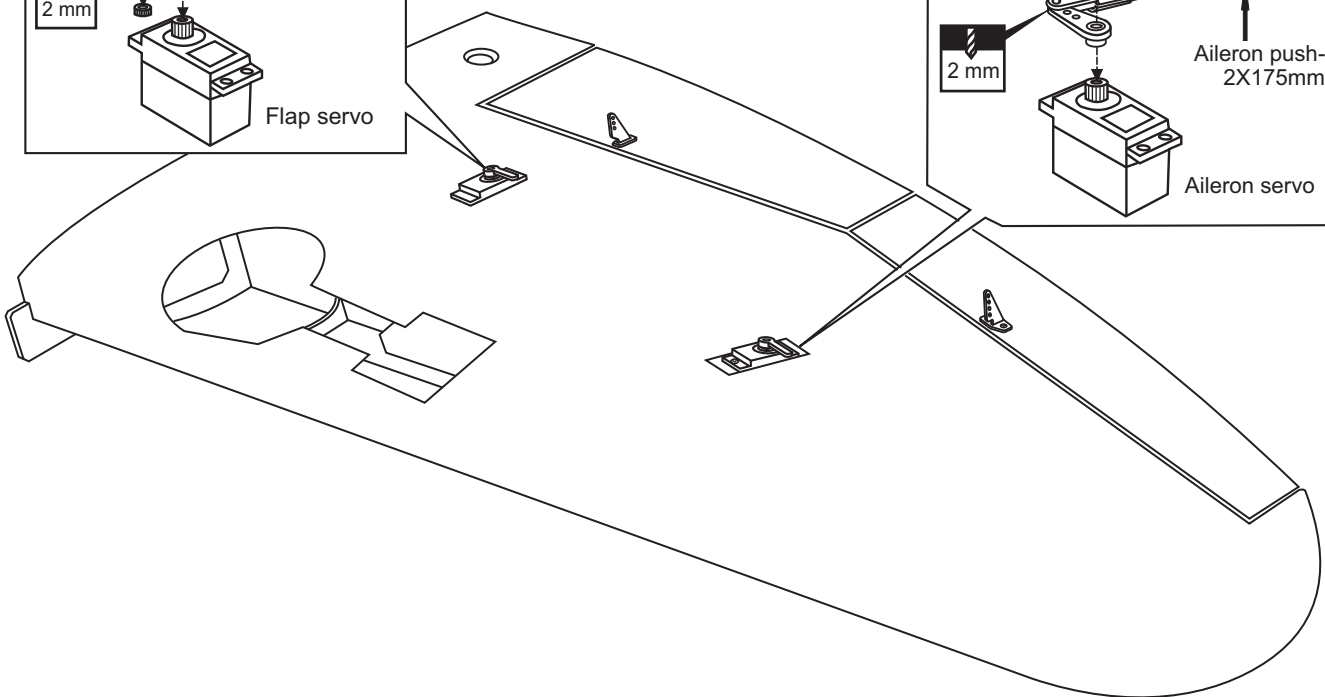
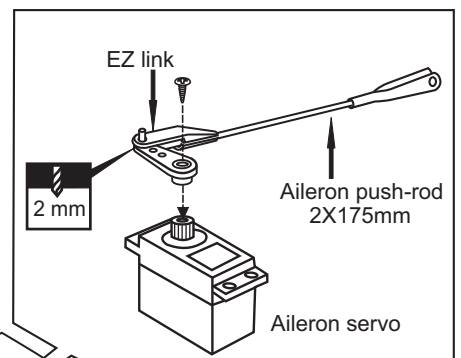
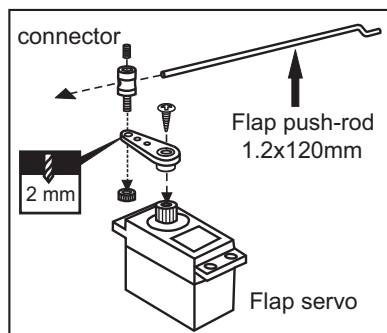

- |                                 |                                |
|---------------------------------|--------------------------------|
| Plastic EZ link .....2          | Connector .....2               |
| Steel clevis .....2             | Flap push rod 1.2x120mm .....2 |
| Aileron push rod 2x175mm .....2 |                                |

# P-47 THUNDERBOLT 5- JOINING THE WING

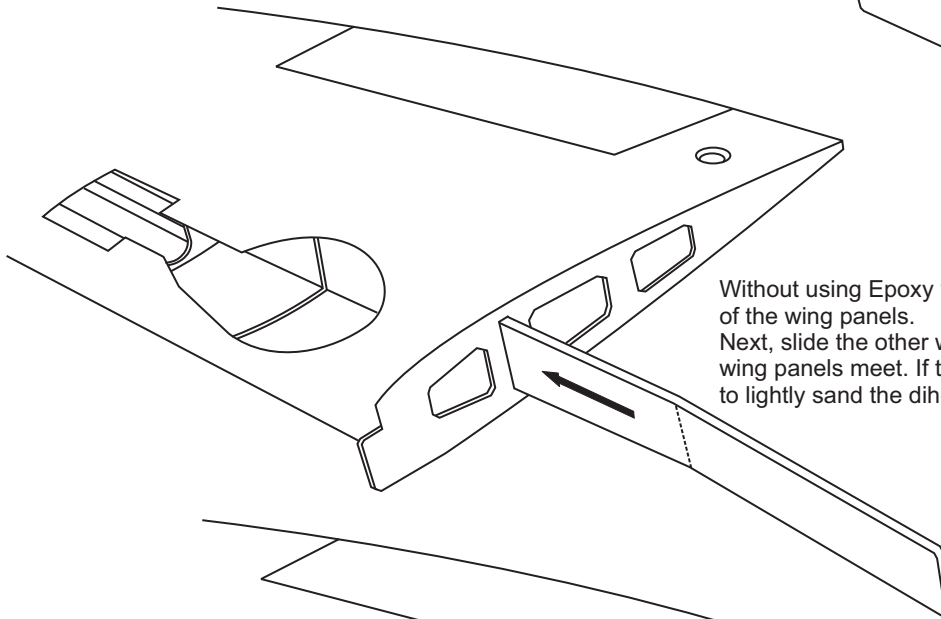
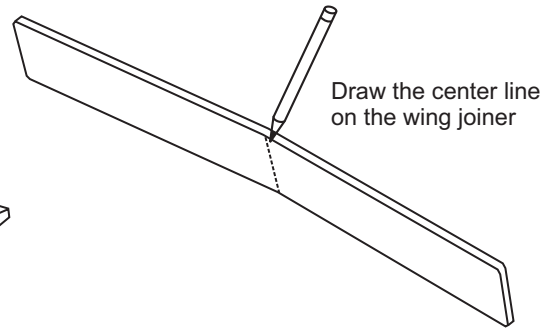

Without using Epoxy yet, trial fit the wing joiner into one of the wing panels. Next, slide the other wing half onto the dihedral brace until the wing panels meet. If the fit is overly tight, it may be necessary to lightly sand the dihedral brace.

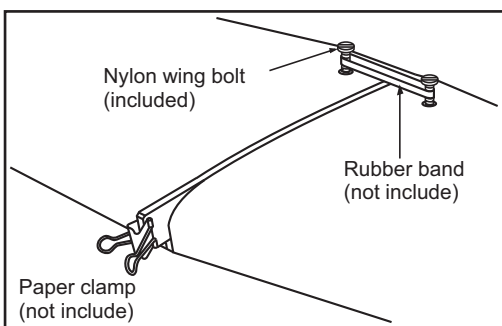
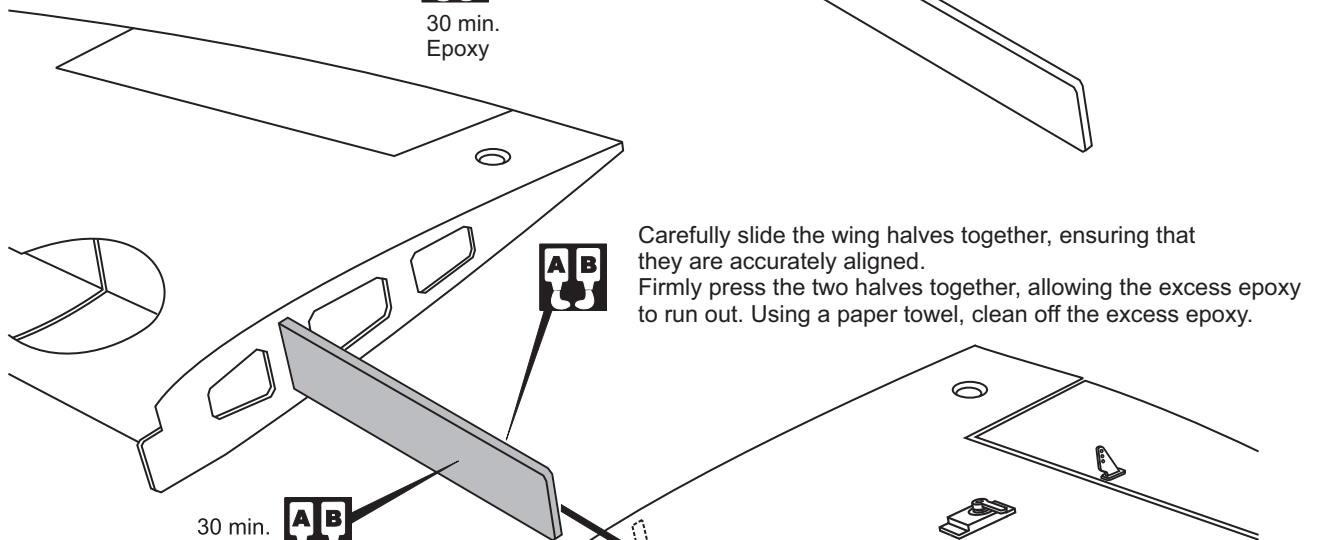
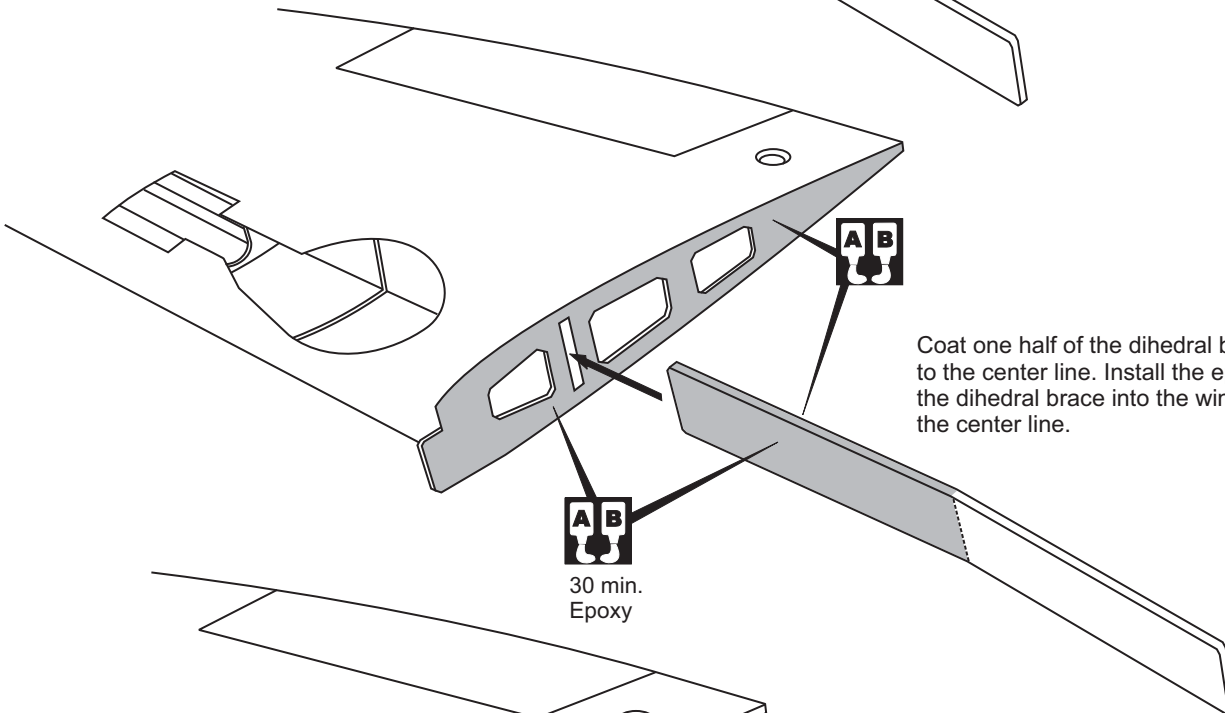

Hold the wing halves together with paper clamp and rubber band.

## P-47 THUNDERBOLT 6- FIXED GEAR ASSEMBLY

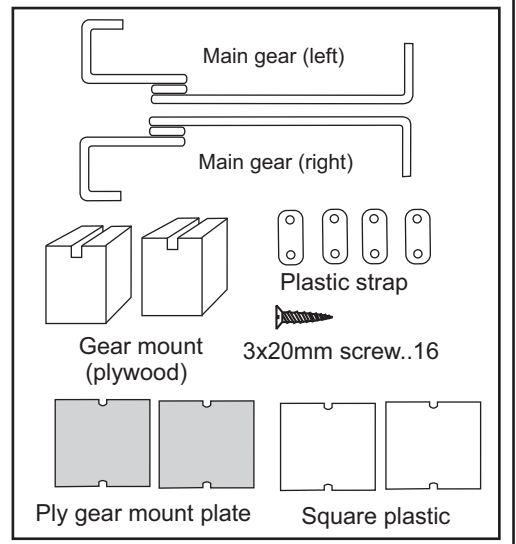
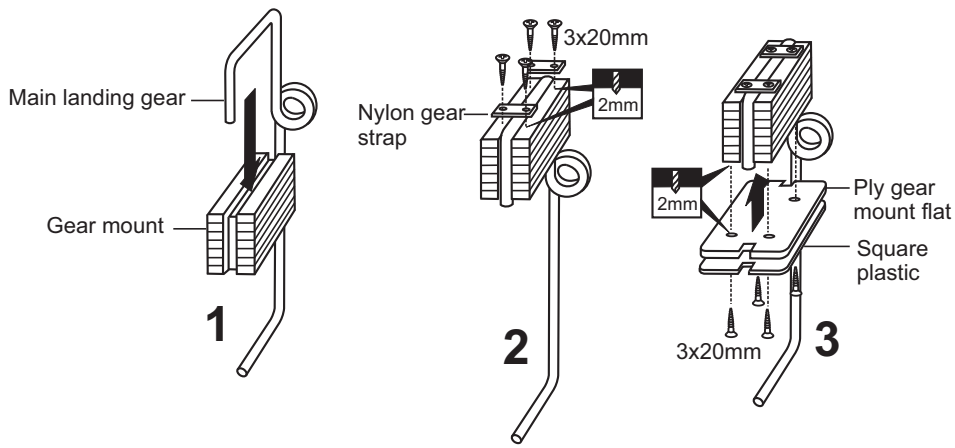

## P-47 THUNDERBOLT 7- FIXED GEAR INSTALLATION

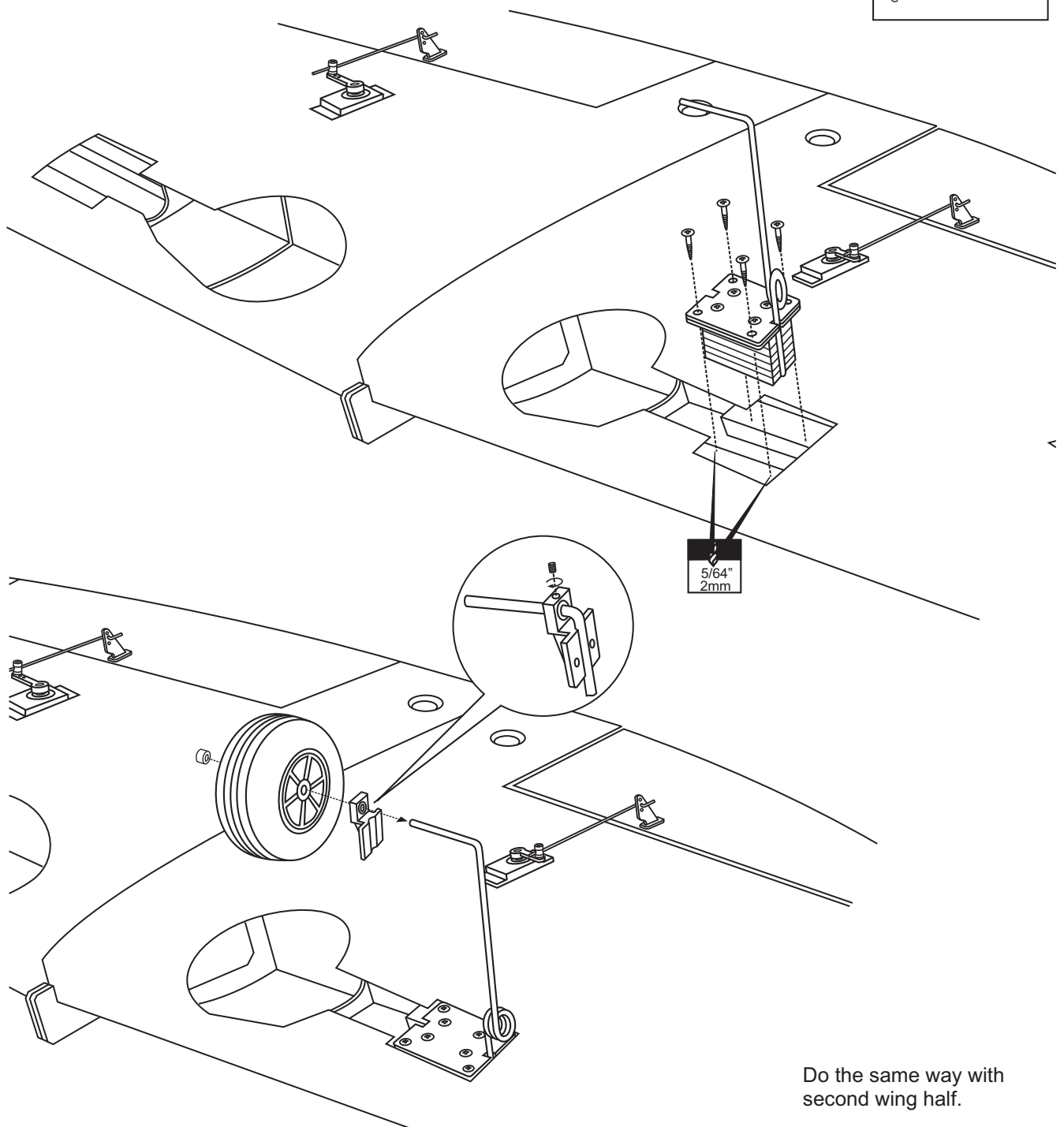

Do the same way with second wing half.



## P-47 THUNDERBOLT 8- GEAR DOOR

In case of fixed gear using

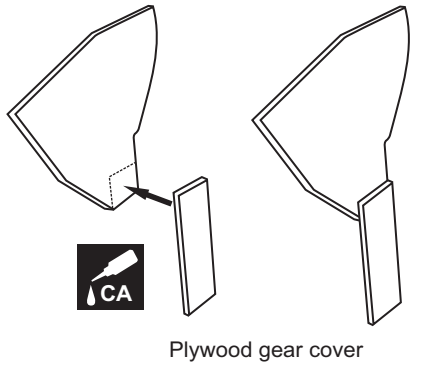

Plastic strap

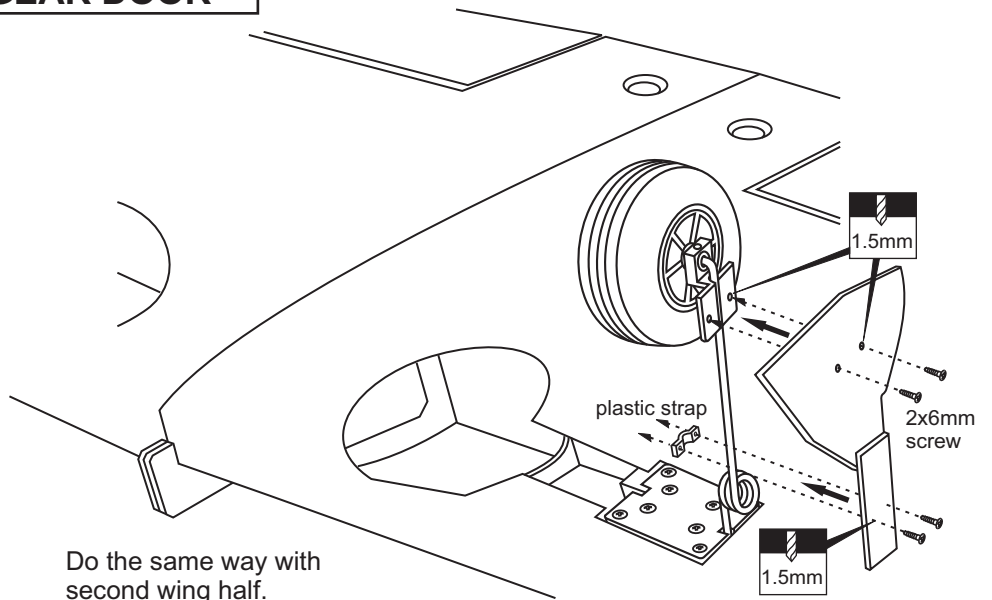

Do the same way with second wing half.

## P-47 THUNDERBOLT 9- ELECTRIC RETRACT GEAR INSTALLATION

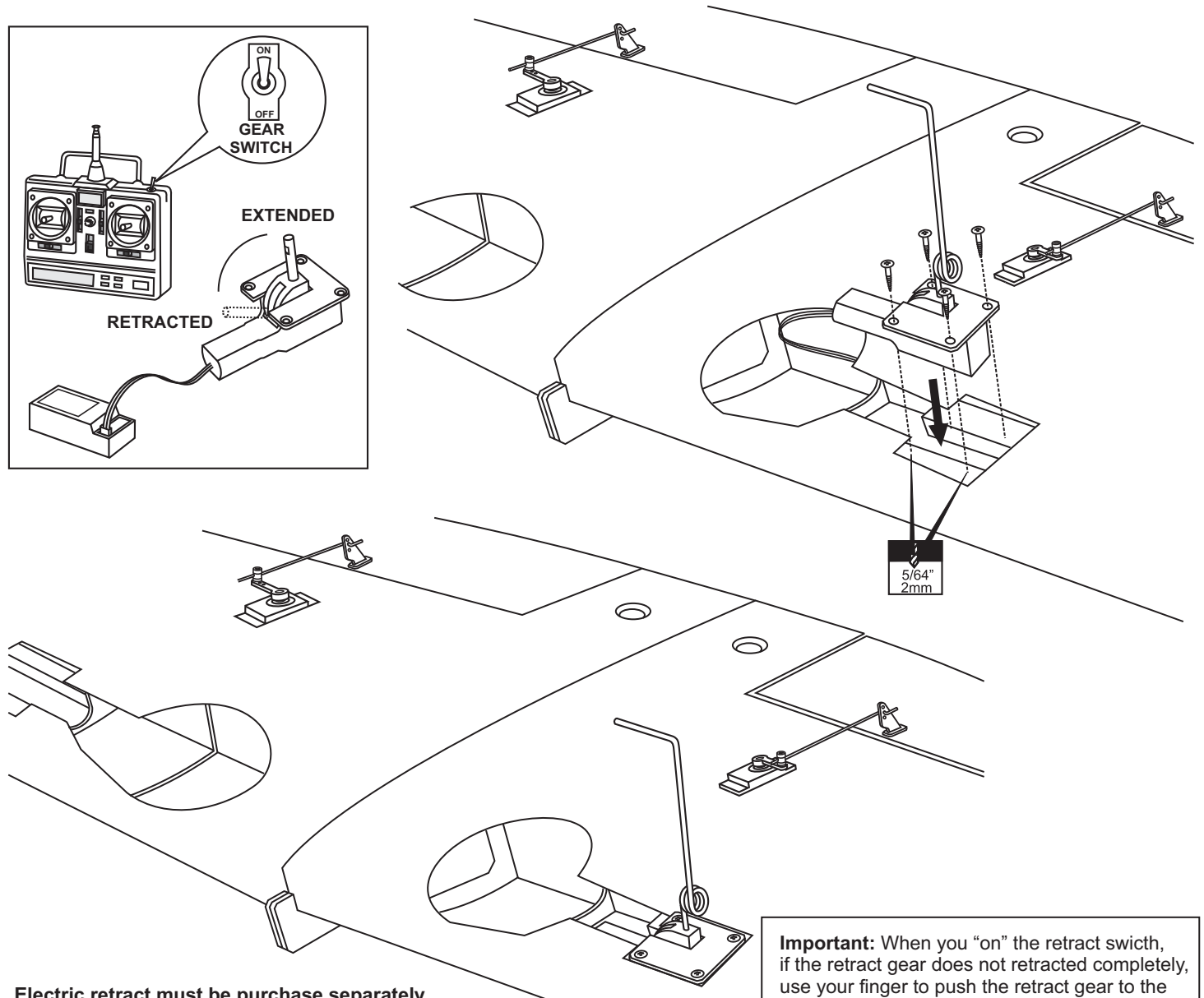
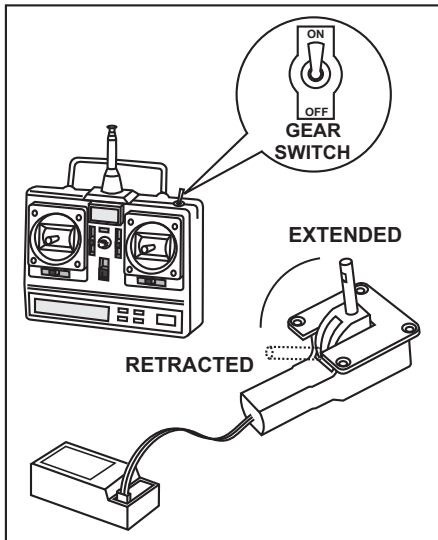

Electric retract must be purchase separately

Do the same way with second wing half.

**Important:** When you "on" the retract swithch, if the retract gear does not retracted completely, use your finger to push the retract gear to the completely retrated position, it will extend. Then use the hobby knife to remove the place where the retract gear is entangled.

## P-47 THUNDERBOLT 10- STRUT AND GEAR DOOR ASSEMBLY

### Wheel Cover Parts 3mm plywood

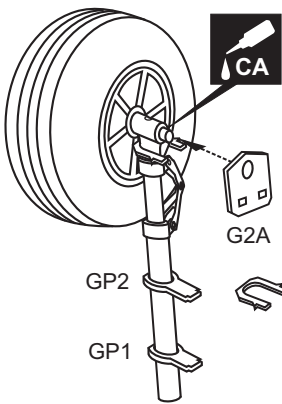
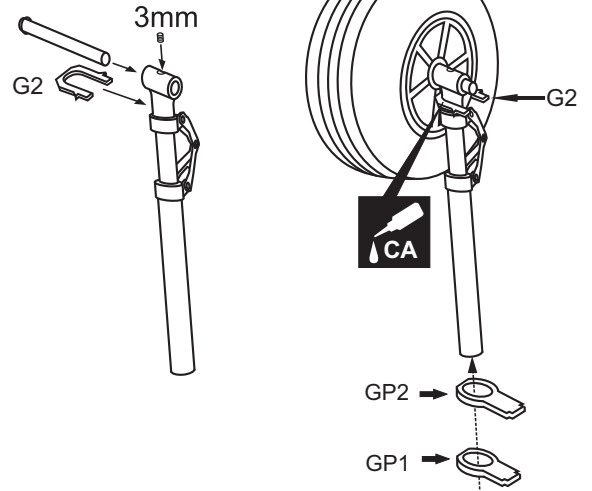
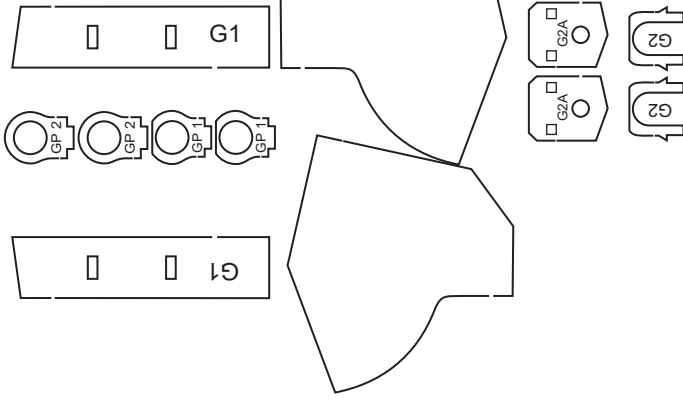

Glue the G2A to the Strut and G2, But **do not glue** the GP2 and GP1 to the Strut in this time.

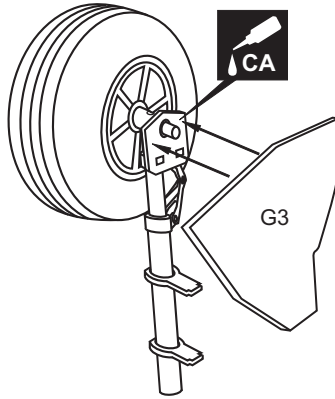

Glue the G3 to the G2A

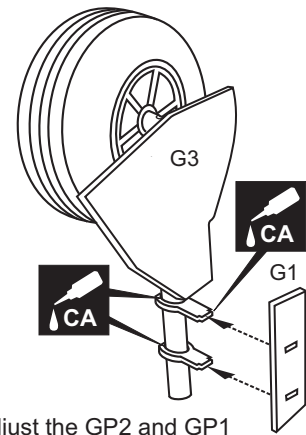

Adjust the GP2 and GP1 before glue them to the G1. Glue the GP2 and GP1 to the Strut.

## P-47 THUNDERBOLT 11- STRUT AND GEAR DOOR ASSEMBLY

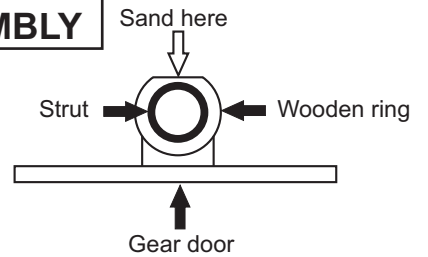
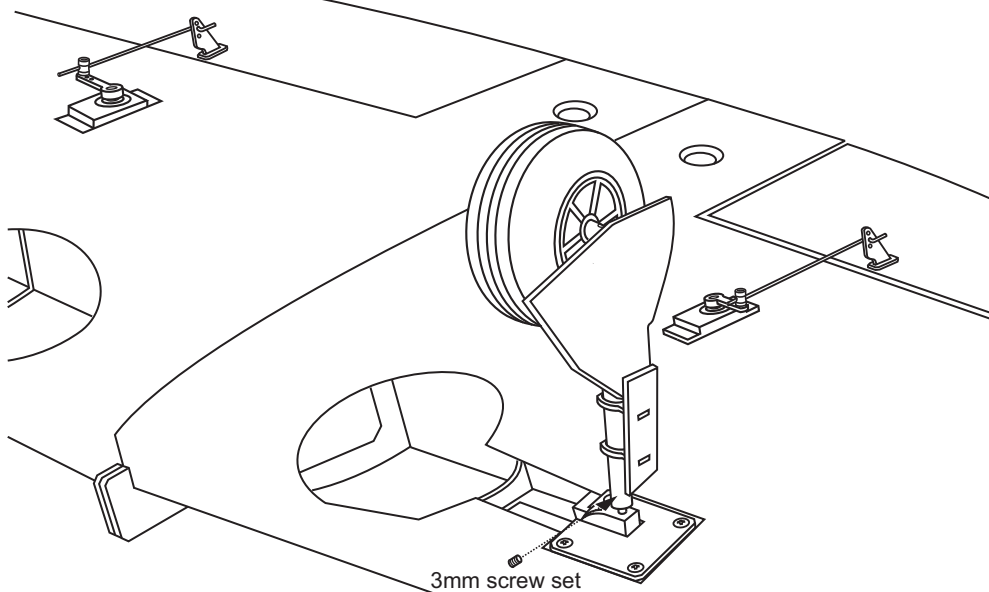

Sand here  
Strut → Wooden ring  
Gear door

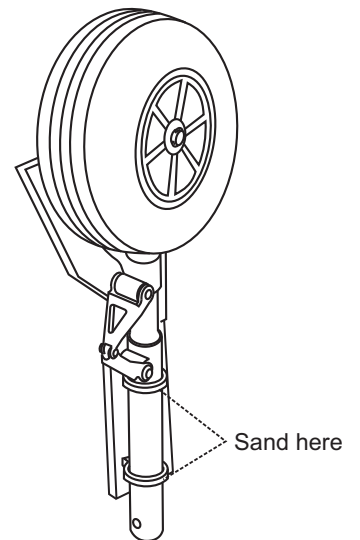

Lightly sand the wooden rings to be sure that the struts locks in retracted position.

**Important:** When you "on" the retract switch, if the retract gear does not retracted completely, use your finger to push the retract gear to the completely retracted position, it will extend. Then use the hobby knife to remove the place where the retract gear is entangled.

## P-47 THUNDERBOLT 12- WING INSTALLATION

6x50mm nylon bolt

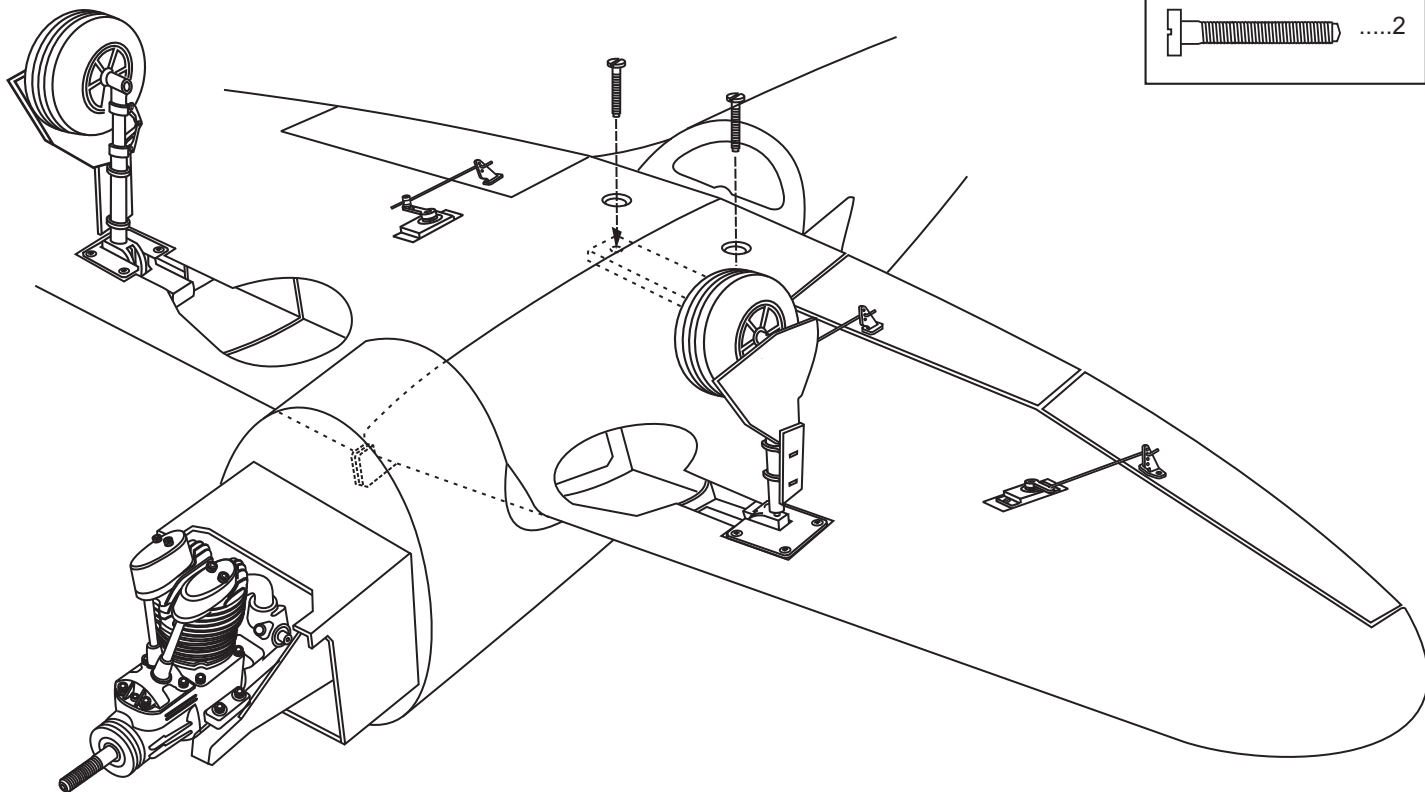

## P-47 THUNDERBOLT 13- STABILIZER INSTALLATION

Push the horizontal stabilizer into the slot on the fuselage as show. Check the alignment of the horizontal stabilizer by measuring from a fixed point along the center line of the fuselage to the leading edge on each side of the horizontal stabilizer. The distance must be equal on both sides . If not, adjust the stabilizer until the measurements are the same (see picture below:  $A=A'$ ).

Cut away only the covering **13A**

Using a sharp hobby knife, carefully cut away the covering around of all slots for the horizontal stabilizer and vertical fin installation.

**13B** Remove the left and right elevator out of the horizontal stabilizer.

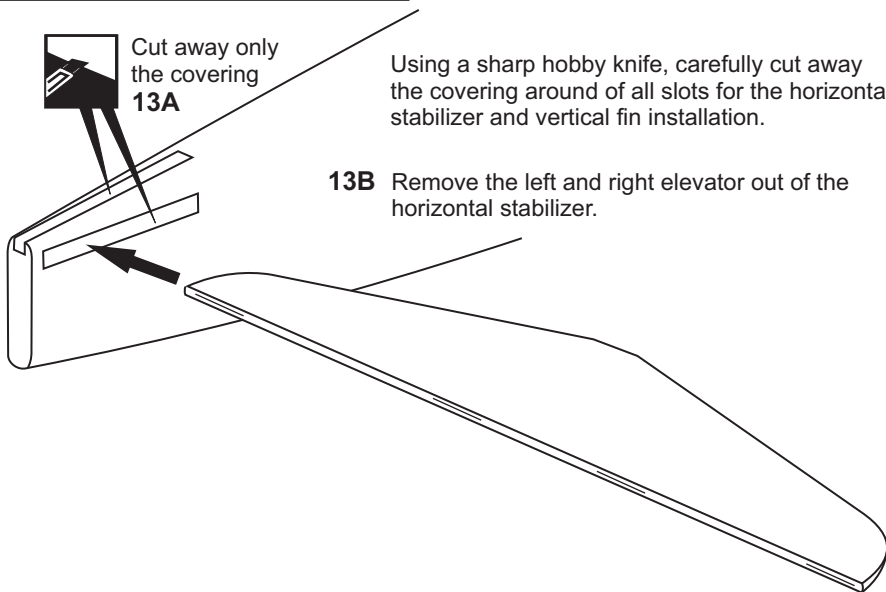
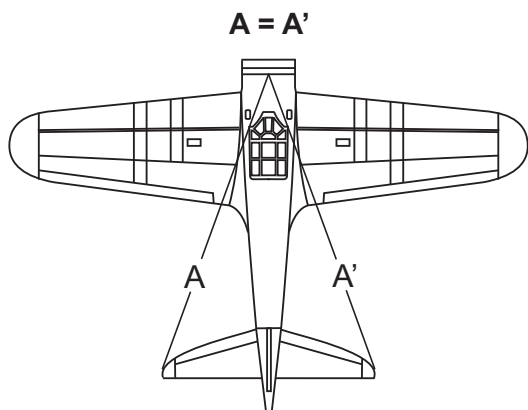

Cut away only the covering both side

**13D**

**13C** When you are satisfied with the alignment, use a pencil to trace around the top and bottom of the stabilizer where it meets the fuselage .

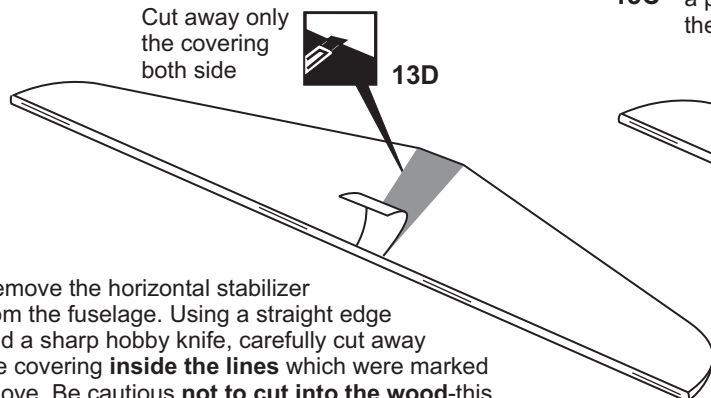

Remove the horizontal stabilizer from the fuselage. Using a straight edge and a sharp hobby knife, carefully cut away the covering **inside the lines** which were marked above. Be cautious **not to cut into the wood**-this will weaken the structure .

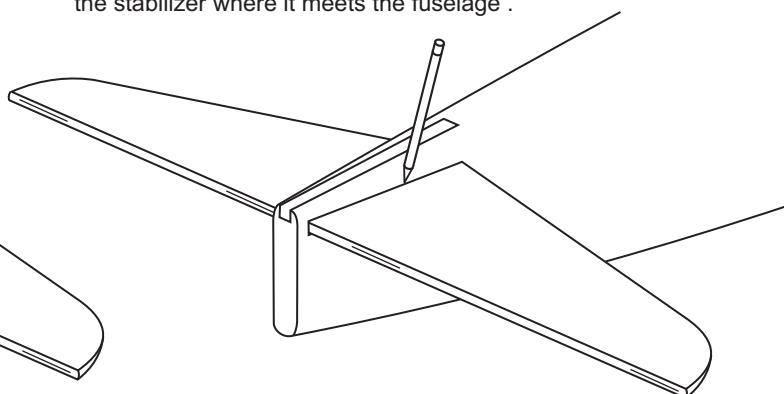

# P-47 THUNDERBOLT 14- STABILIZER INSTALLATION

B=B'

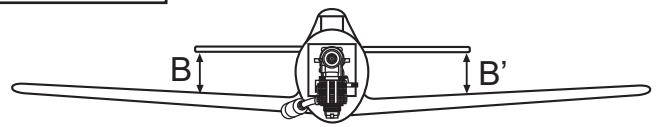

Apply thin CA glue into the slot where the fuselage meet the horizontal stabilizer.

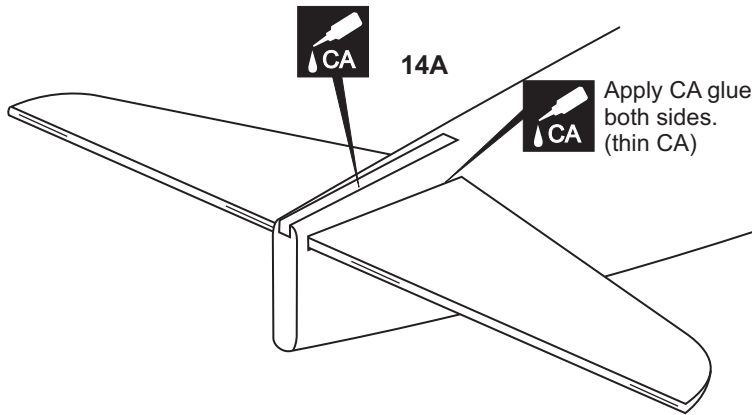

14A

Apply CA glue both sides. (thin CA)

Install the horizontal stabilizer onto the fuselage and adjust the alignment as described in steep 13A. Note: it is important to ensure that the horizontal stabilizer is also level in regards to the wing. The distance must be equal on both sides. If not, adjust the stabilizer until the measurements are the same. Apply the thin CA along the area where the covering was removed in the previous step and to the fuselage where the horizontal stabilizer mounts .

14B

Pull the rudder out of the vertical fin. Carefully, push the vertical fin into the slot on the fuselage as shown (14B).

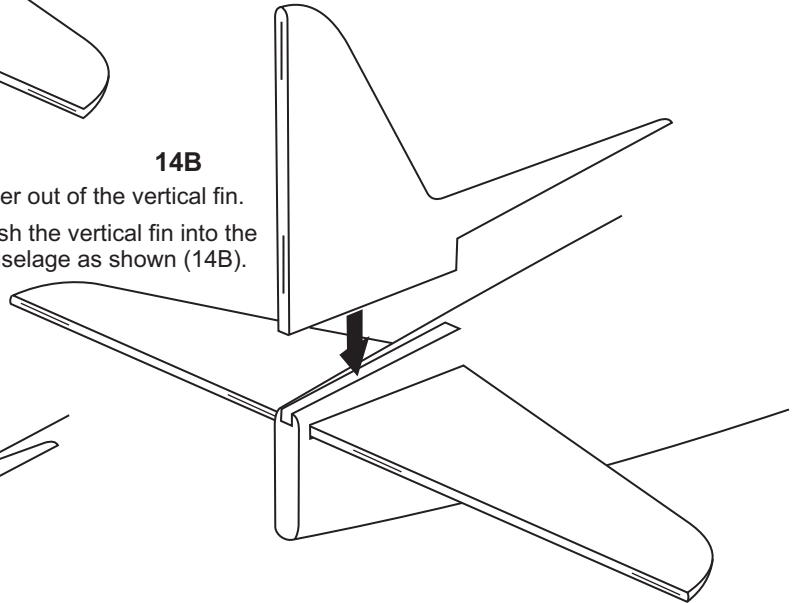

14C

90 degree triangle →

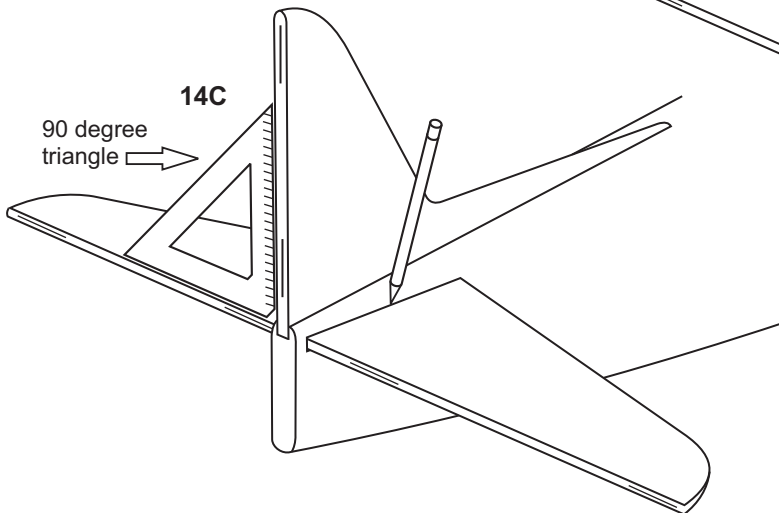

Trial fit the vertical fin in position. Using a 90 degree triangle, ensure that the vertical stabilizer is perpendicular to the horizontal stabilizer (14C).

Using a pencil, trace around the vertical stabilizer where it meets the fuselage. Remove the vertical stabilizer from the fuselage.

Remove the vertical stabilizer from the fuselage. Using a sharp hobby knife, carefully cut away the covering **below the lines** which were drawn in the previous step. **Do not cut into the woods** as this will affect the structural integrity of the stabilizer (14D).

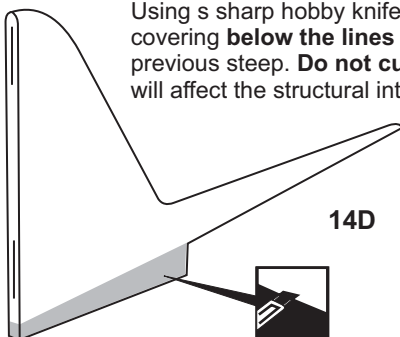

14D

Cut away only the covering

14E

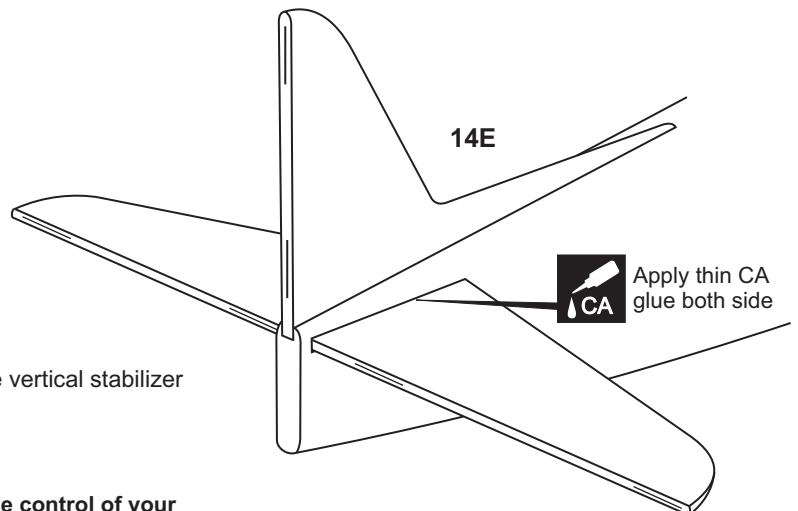

Apply thin CA glue both side

Insert the vertical fin into the fuselage, precisely align the vertical stabilizer as described in step 14C.

**! Securely glue together. If coming off during fly, you lose control of your air plane.**

# P-47 THUNDERBOLT 15- ELEVATOR AND CONTROL HORN

Without using glue yet, push the elevator and its hinges into the hinge slots in trailing edge of the horizontal stabilizer.

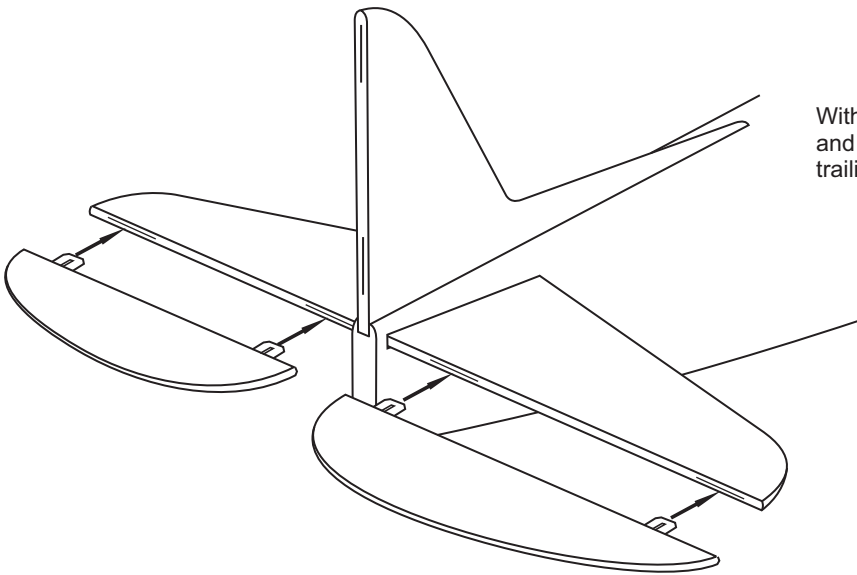

Apply thin CA glue both side

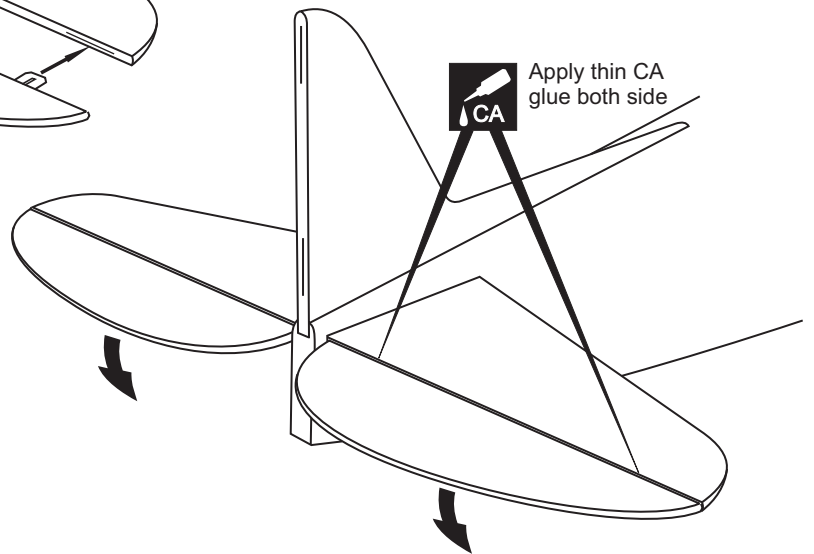

TOP-SIDE

HORIZONTAL STABILIZER

Apply a thin layer of petroleum jelly



Apply thin CA glue on the top of the hinge

TOP-SIDE

HORIZONTAL STABILIZER

Do the same way with the bottom side of elevator and with the second elevator.

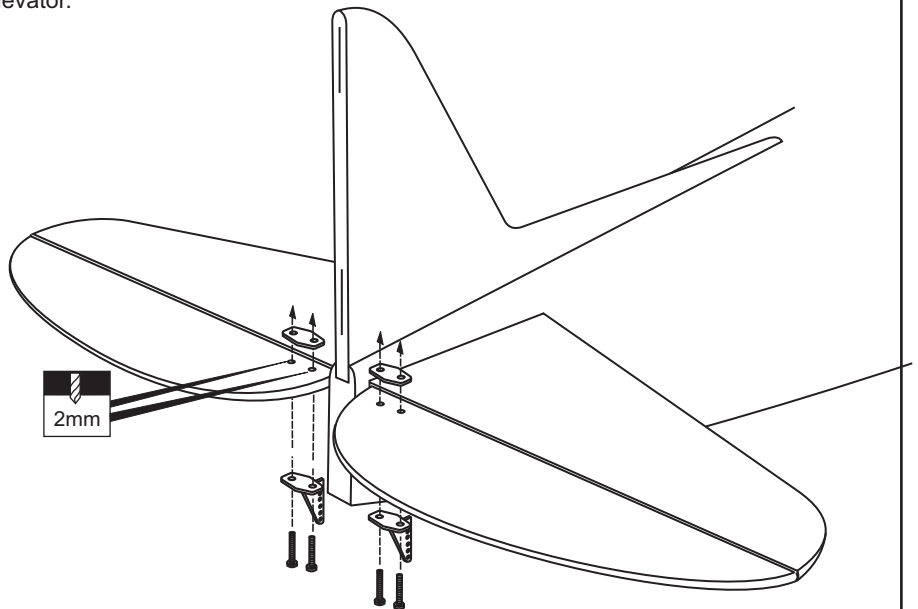

2mm

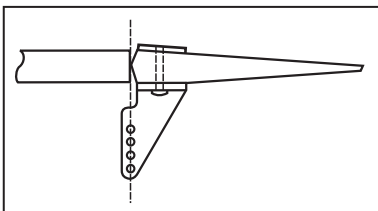

Control horn



.....2

2x12mm screw





.....4

# P-47 THUNDERBOLT 16- RUDDER AND CONTROL HORN

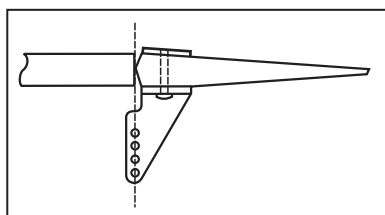
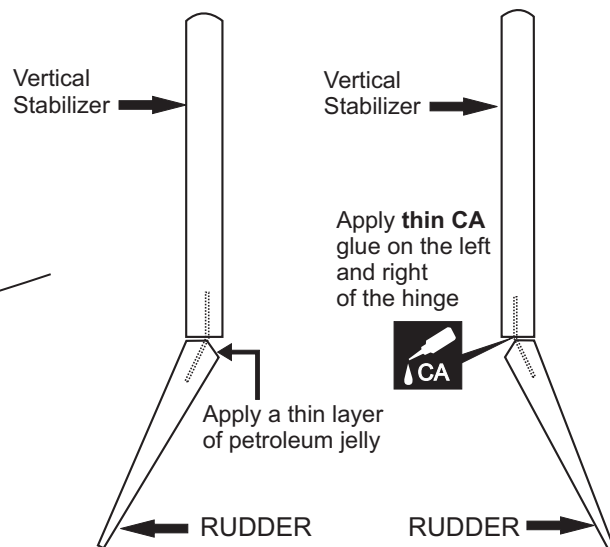
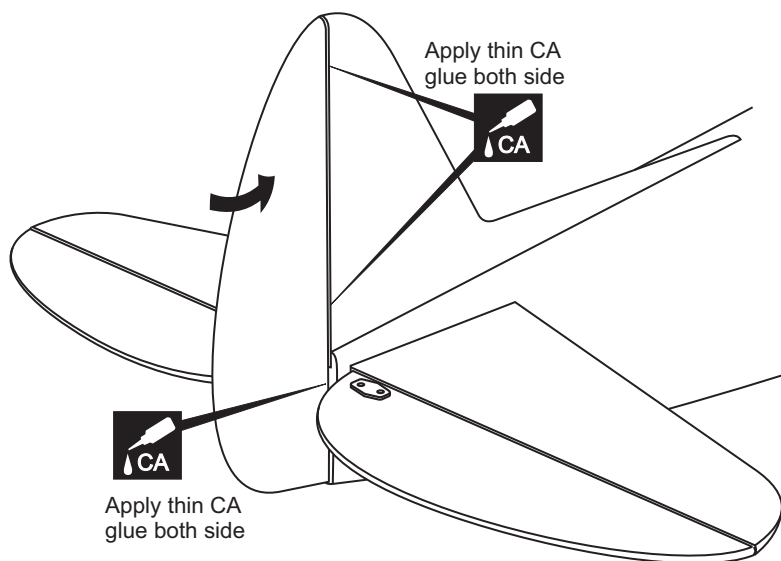
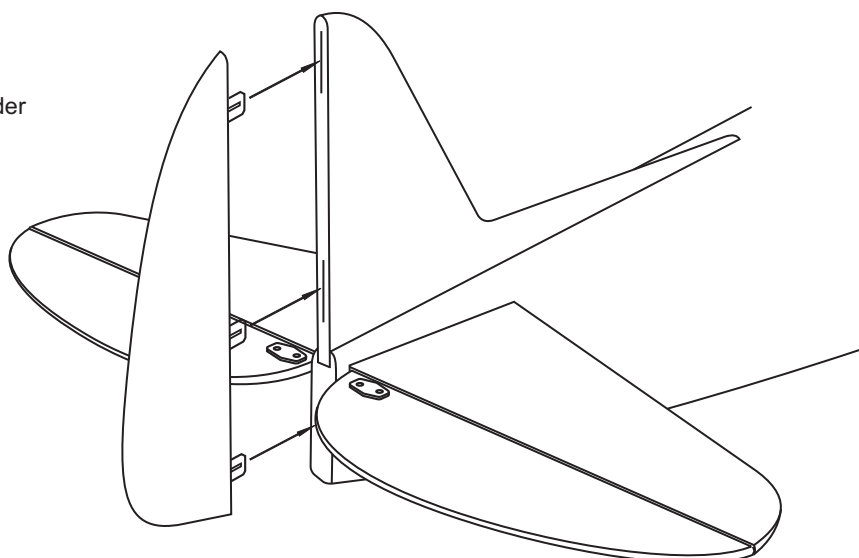
Without using glue yet, push the rudder and its hinges into the hinge slots in trailing edge of the vertical stabilizer.



- Control horn
-  .....3
  - 2x12mm screw
  -  .....6

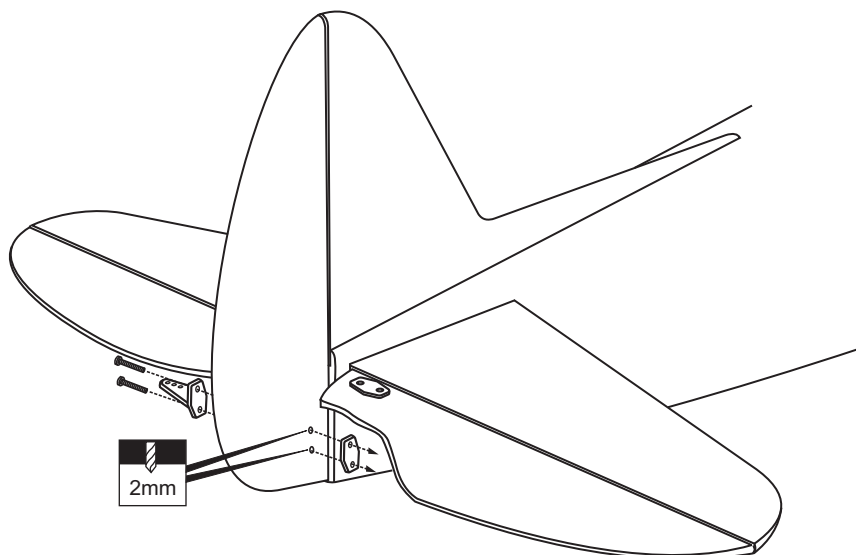

# P-47 THUNDERBOLT 17- TAIL GEAR INSTALLATION

- 1- Insert the tail wheel pushrod into the hole on the tail gear control horn (as show).
- 2- Install the tail wheel control horn in place.
- 3- Instal the tail wheel gear in place.
- 4- Secure the tail wheel control horn in place using a 5/64"(2mm) screw set, Ensure smooth non-binding movement.

1.2x800mm rod	.....1
3x3mm screw	.....1
Tail wheel control-horn	.....1
Tail landing gear	.....1
2mm I.D collar	.....2
25mm wheel	.....1

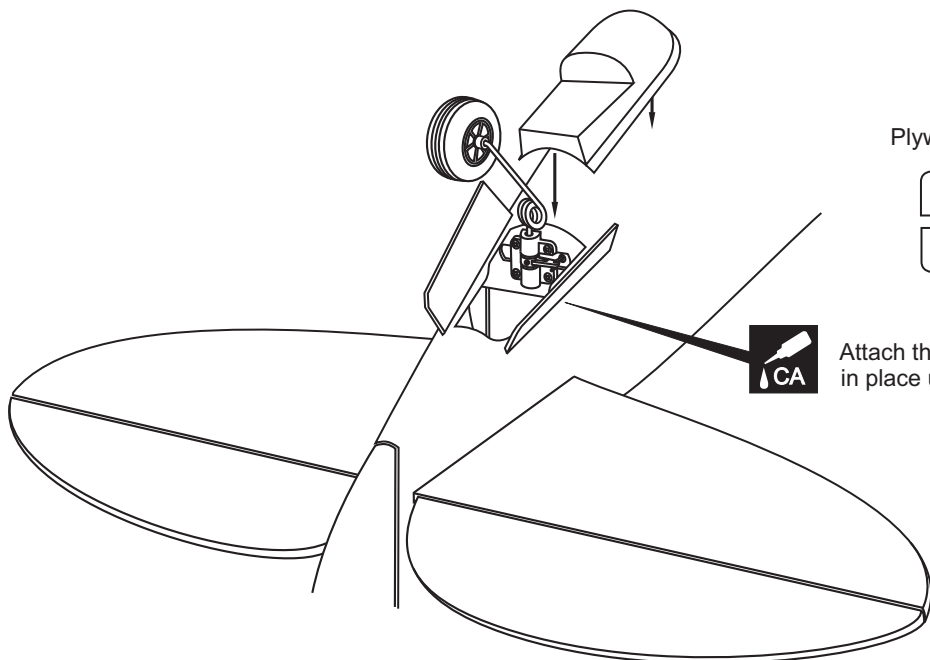
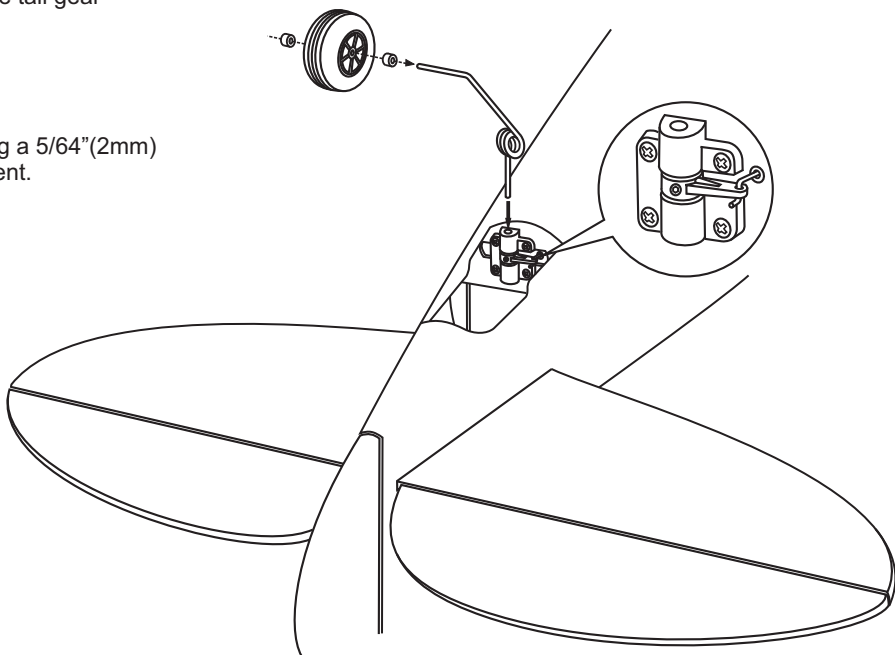

Plywood Tail wheel door

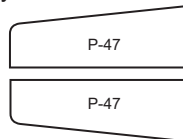

Attach the tail wheel doors in place using CA glue.

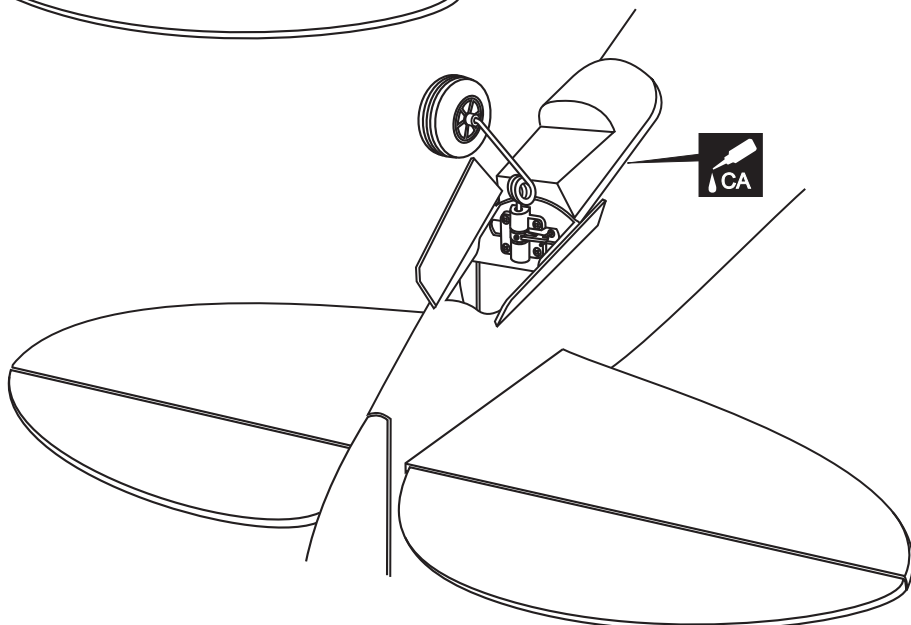

# P-47 THUNDERBOLT 18- SERVO AND LINKAGES

Insert the rudder push-rod from the rear of the fuselage.   
Screw the clevis mid-thread, then connect to the rudder control horn.

Insert the two elevator push-rod from the rear of the fuselage.  
Screw the clevis mid-thread, then connect to the elevator control horn.

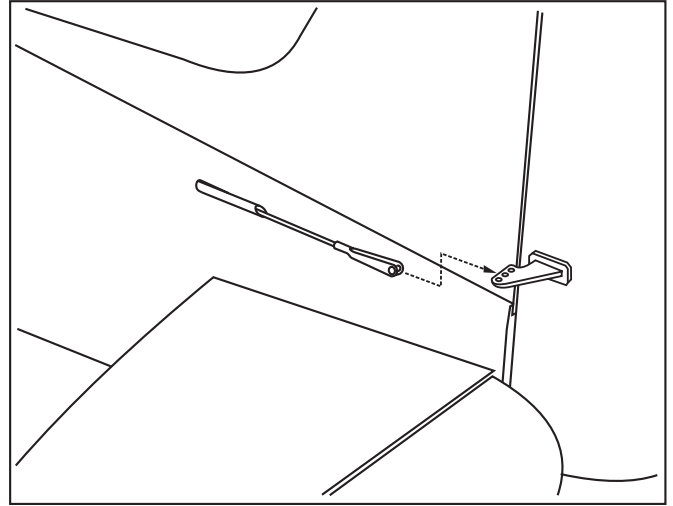

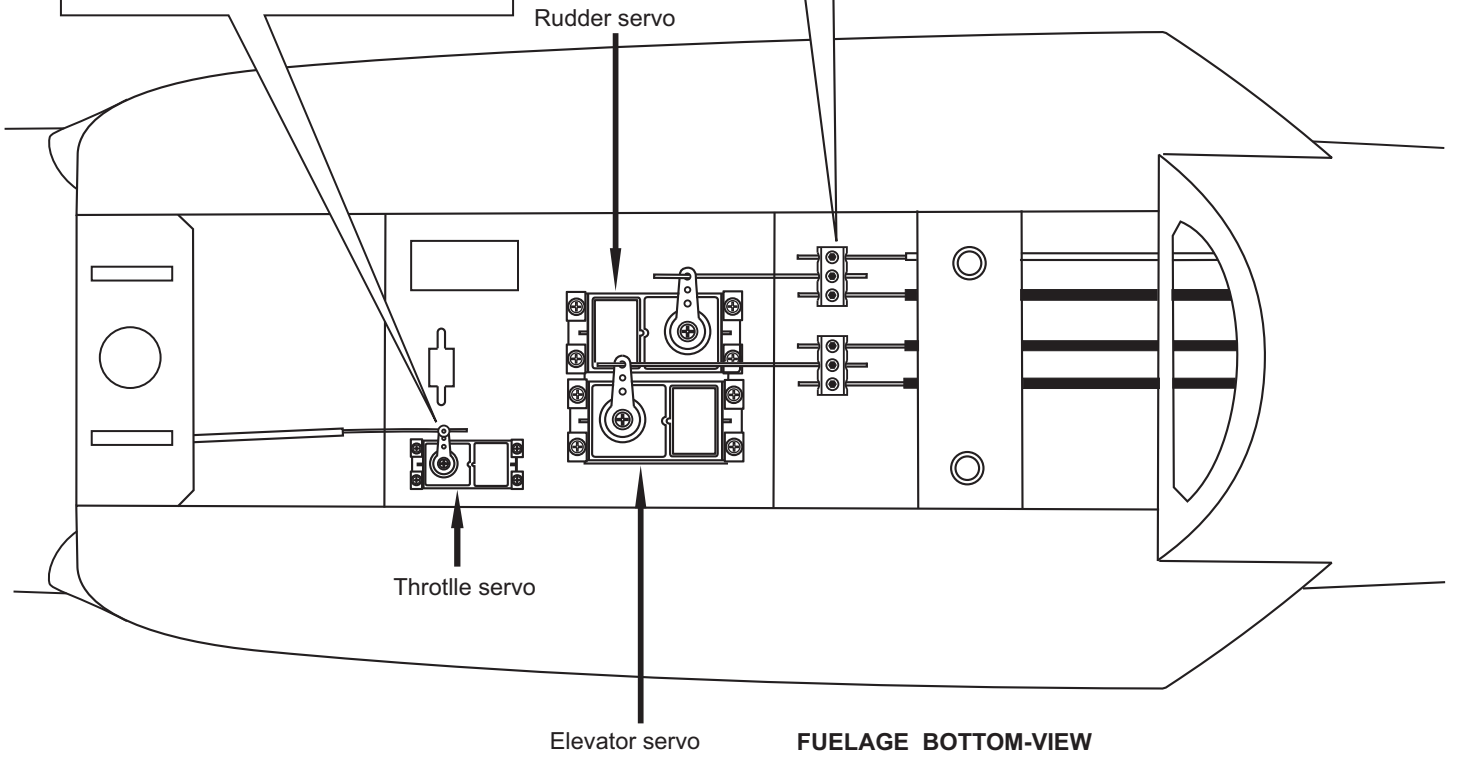
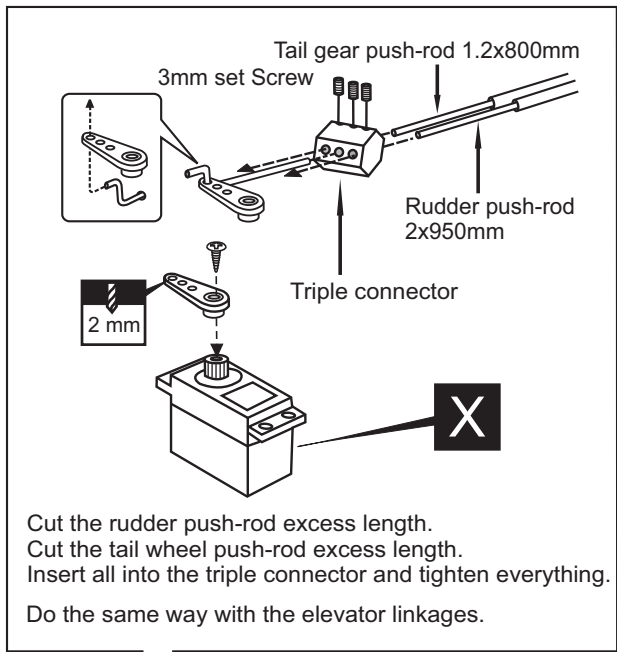
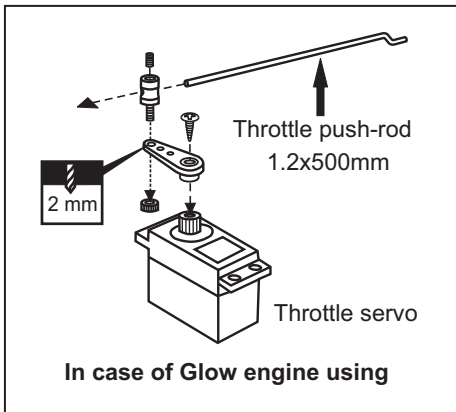

- Steel clevis .....3
- 2x950mm rod .....3
- (2 x120mm) rod .....2
- (1.2 x500mm) throttle rod .....1
- Triple connector .....2
- 2mm .....1



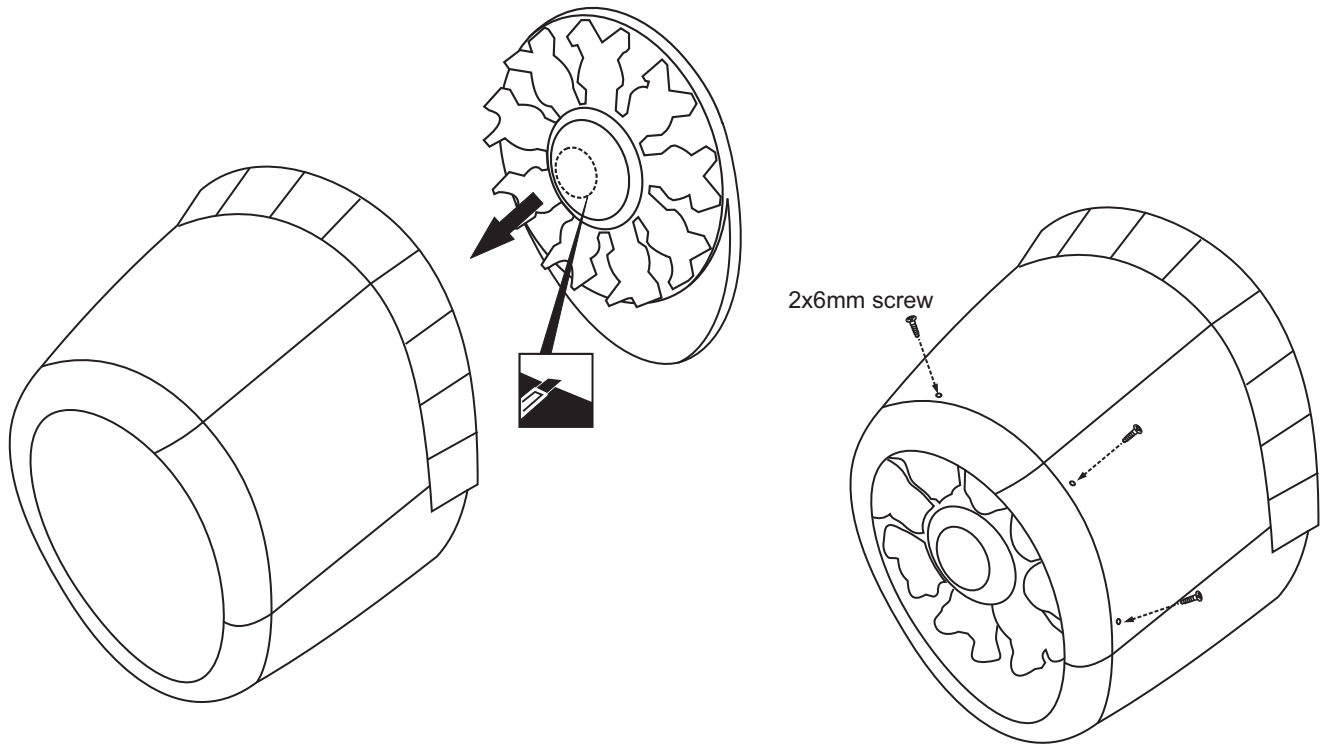

# P-47 THUNDERBOLT 19- FIBERGLASS COWL AND DUMMY ENGINE



- 2x6mm screw  
 .....6
- 2.5x10mm screw  
 .....5

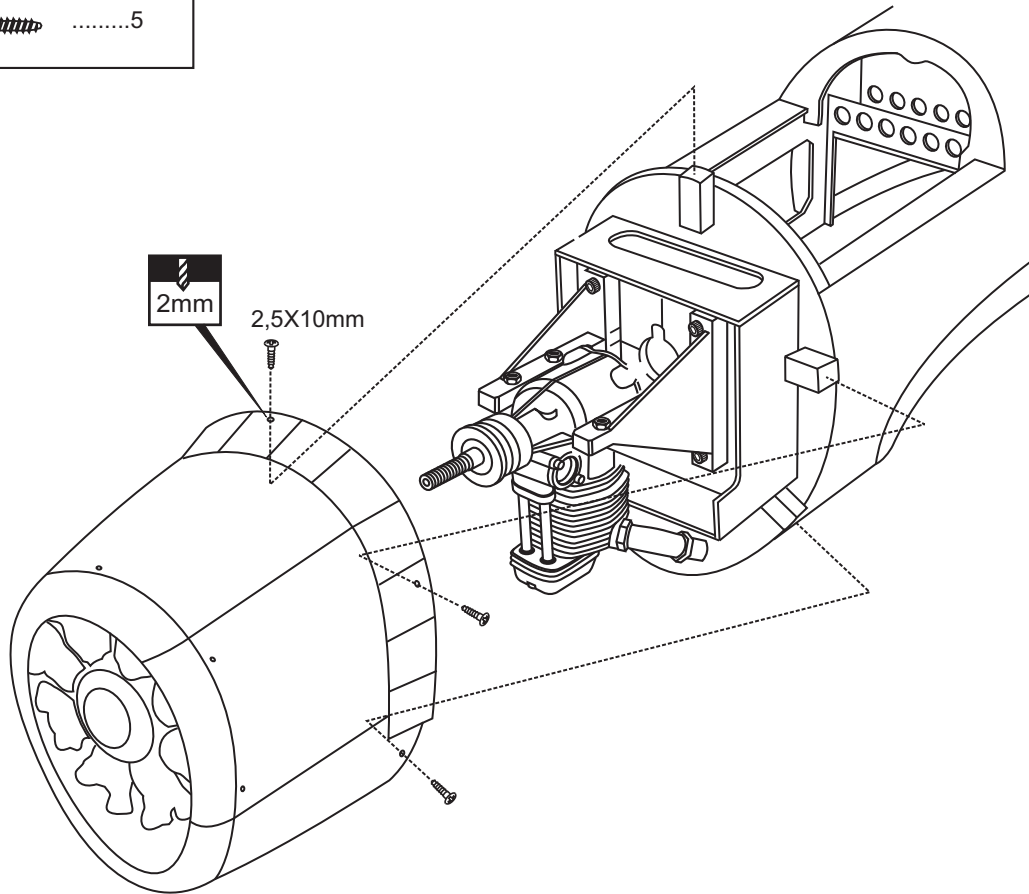

**P-47 THUNDERBOLT 20- BOTTOM COVER**

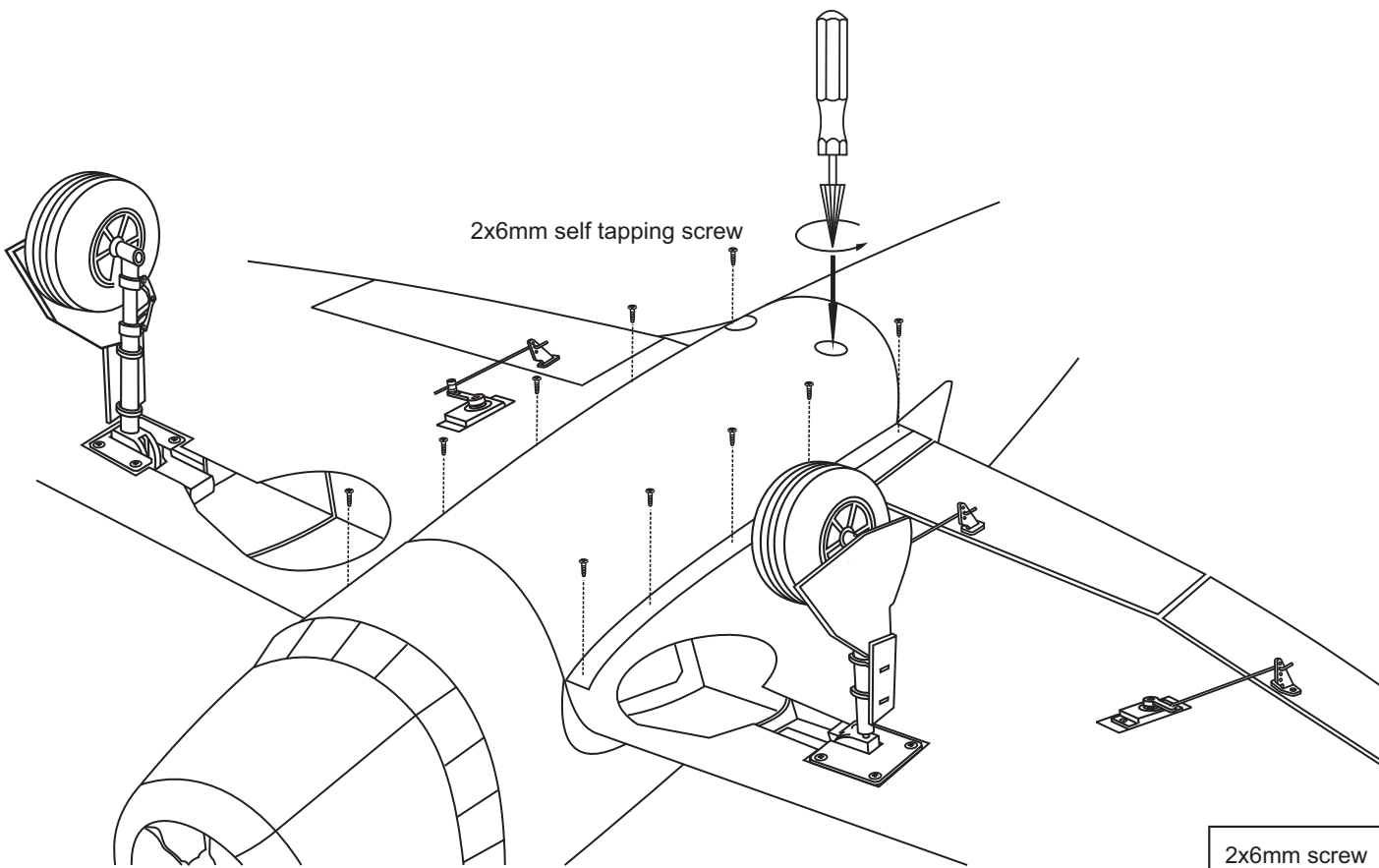
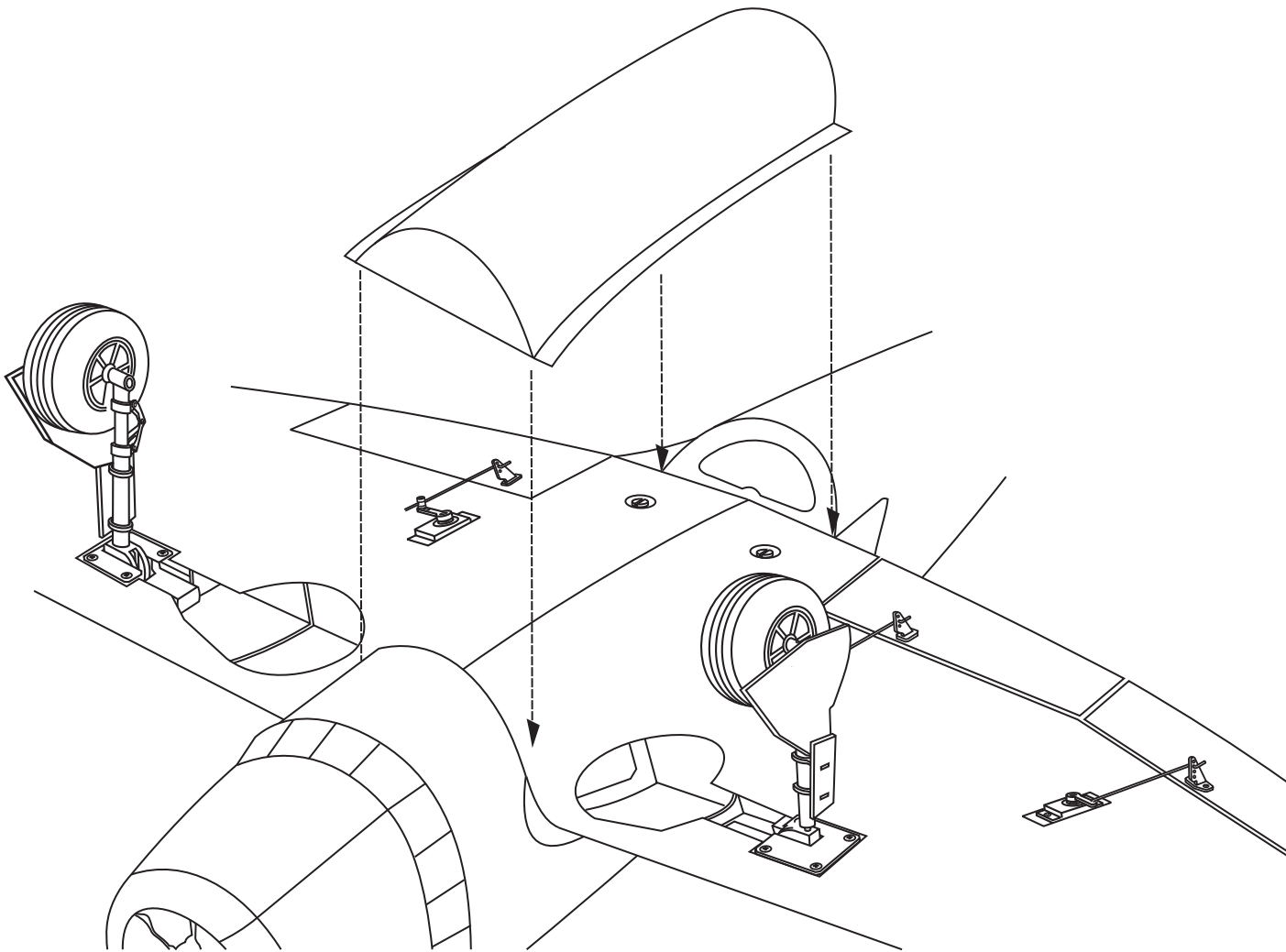

2x6mm screw  
 .....10

**P-47 THUNDERBOLT 21- BOMB ASSEMBLY**

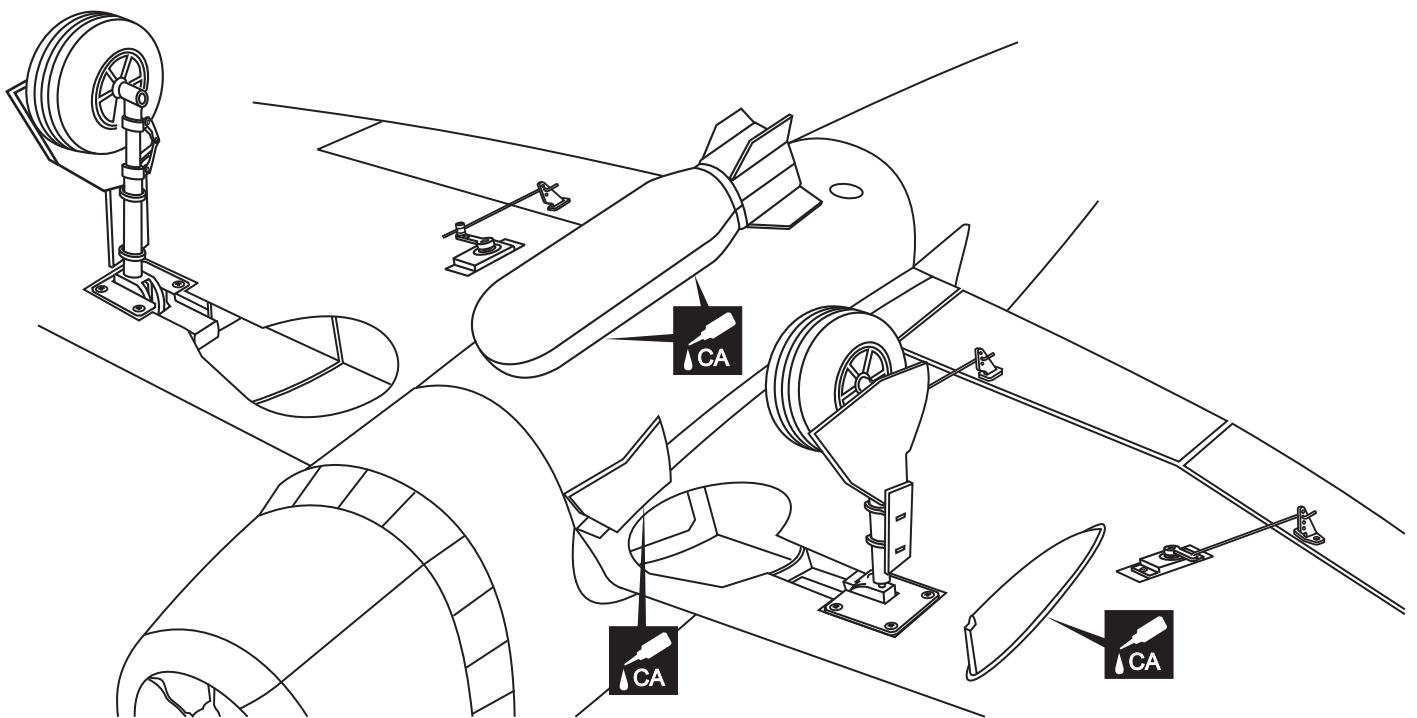
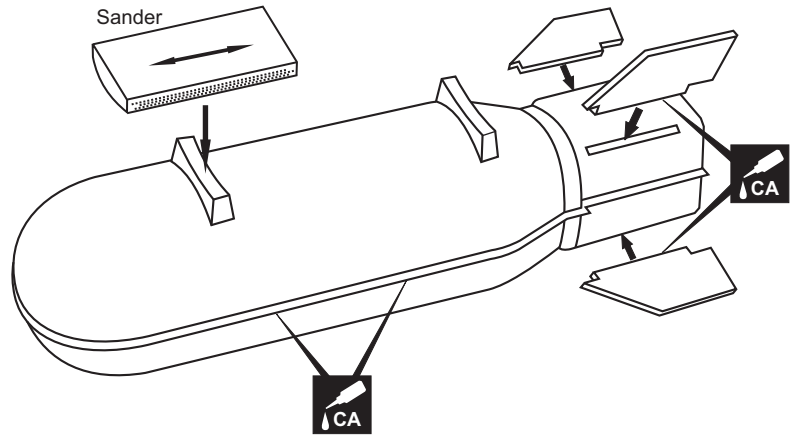
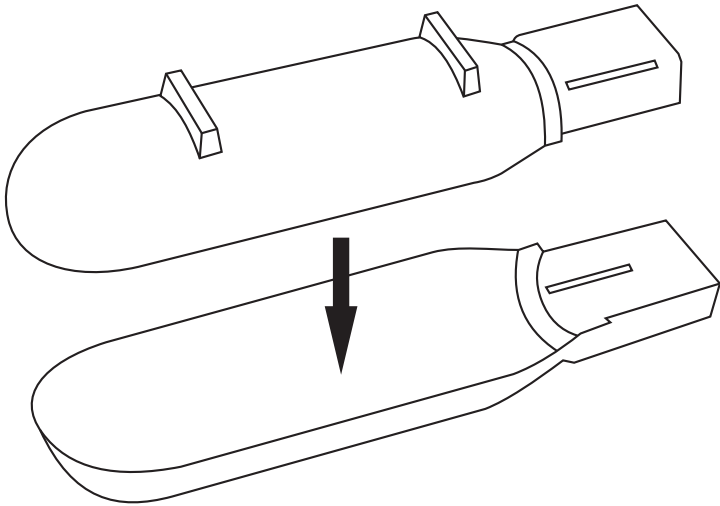





## P-47 THUNDERBOLT 24- STICKER

P-47D "Tarheel Hal" IA-N

433240

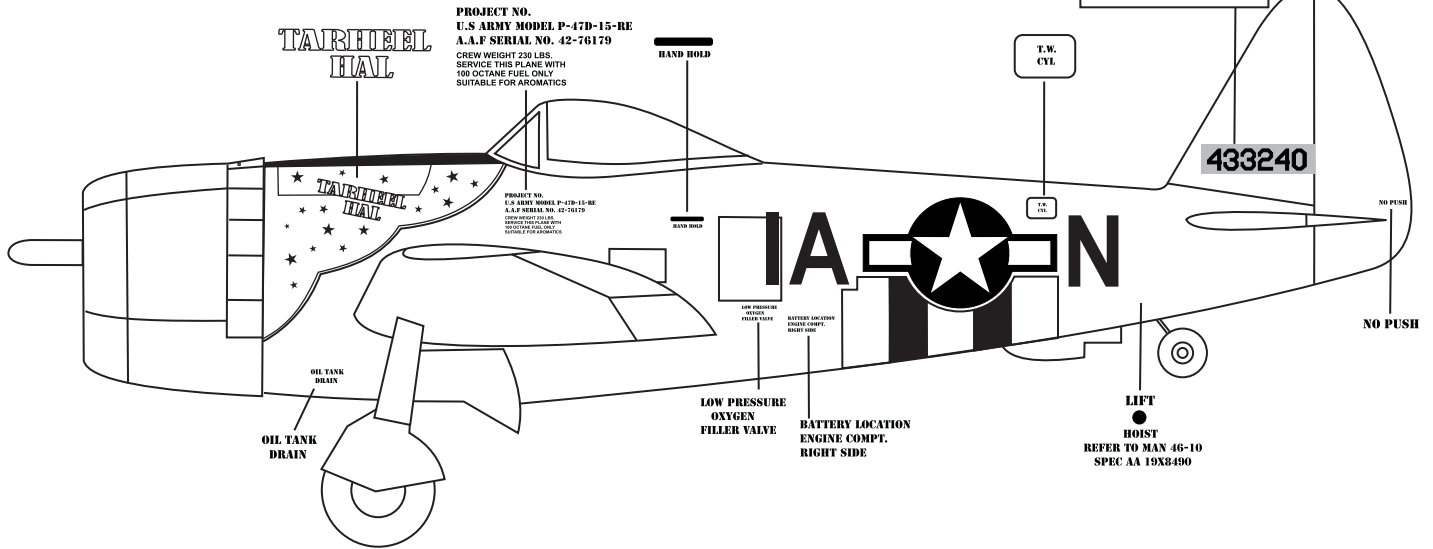

## P-47 THUNDERBOLT 25- BALANCE

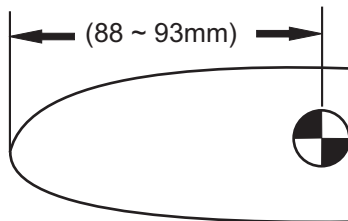

Note: Adjust the location of the battery pack to achieve this C.G. location.

DO NOT try to fly an out-of balance model!

Wing center section

### How to add nose weight

To get the correct C.G., Several strips of lead weight were required in the nose of this model .  
To minimize the amount of weight required, it is desirable to position the weight as far forward as possible.  
IMPORTANT: Recheck the C.G. After the weight has been installed.

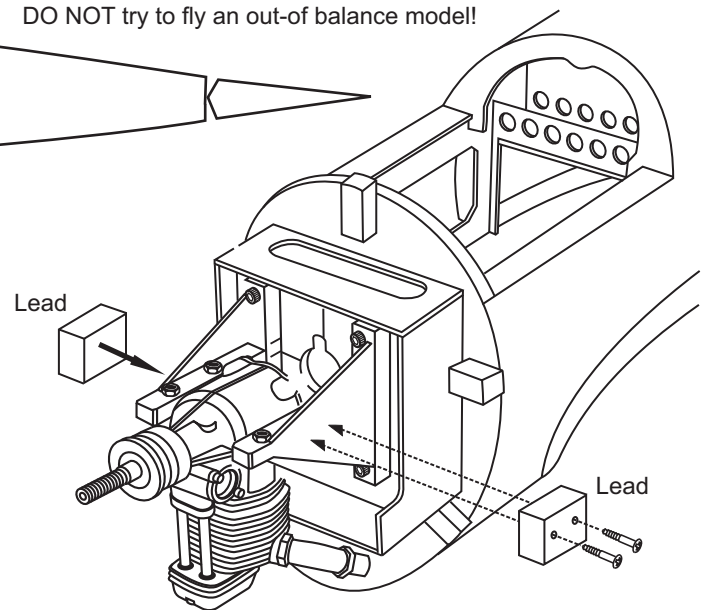

## P-47 THUNDERBOLT 26- CONTROL SURFACE

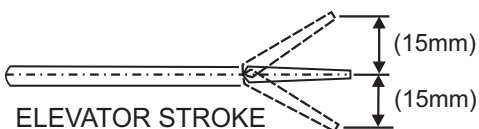

ELEVATOR STROKE

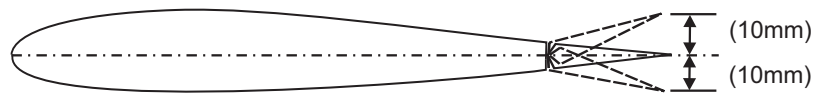

AILERON STROKE

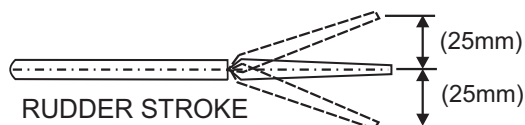

RUDDER STROKE

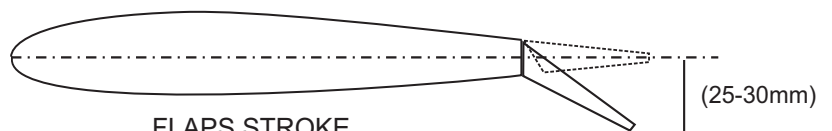

FLAPS STROKE

Adjust the travel of the control surfaces to achieve the values stated in the diagrams.  
These value will be suitable for average flight requirements. Adjust the values to suit your particular needs.