

PICHLER



ARF
ALMOST READY TO FLY
Vorgefertigtes Motorflugmodell
in Holzbauweise für Elektroantrieb

SKY MASTER

TECHNISCHE DATEN

Spannweite = 3000mm / Länge = 2300mm / Abfluggewicht ca. 13kg

RC-FUNKTIONEN

Seiten-, Höhen-, Querruder, Motor.

SPECIFICATIONS

Wingspan = 3000mm / Length = 2300mm / Flying Weight approx. 13kg

RC-Functions

Elevator, Rudder, Aileron, Motor



Achtung: Kein Spielzeug! Für Jugendliche unter 14 Jahren nur unter Aufsicht Erwachsener geeignet.
Warning: This is not a toy! Suitable for young people under the age of 14 with adult supervision.

BAUANLEITUNG / INSTRUCTION MANUAL

1. Inhaltsverzeichnis / Content
2. Sicherheitshinweise / Safety Instructions
3. Erforderliches Zubehör / Required Accessories
4. Montage / Assembly
5. Hinweise zur Bedienung / How To Use
6. Ersatzteile / Spare Parts
- 7. Service & Gewährleistung / Service & Warranty**

2. SICHERHEITSHINWEISE / SAFETY INSTRUCTIONS

ALLGEMEINE SICHERHEITSHINWEISE FÜR MODELLE MIT ELEKTROANTRIEB

- Achtung: Kein Spielzeug! Für Jugendliche unter 14 Jahren nur unter Aufsicht Erwachsener geeignet.
- Verwenden Sie das fertige Modell ausschließlich gemäß seiner vorgesehenen Bestimmung, wie unter dem Kapitel „Hinweise zur Bedienung“ in der Bauanleitung / Bedienungsanleitung erläutert.
- Montieren Sie das Modell grundsätzlich nur nach der Bauanleitung / Bedienungsanleitung zusammen. Nehmen Sie Umbauten nur vor unter Verwendung von empfohlenen original Ersatz- und Zubehörteilen aus dem Hause extron Modellbau.
- Beachten Sie stets die Gebrauchsanweisung anderweitig zur Anwendung kommender Komponenten (Regler, Akku, Fernsteuerung etc).
- Die Inbetriebnahme ist nicht eher gestattet, bis das Modell laut vorliegender Bauanleitung komplett montiert ist.
- Überprüfen Sie vor der Inbetriebnahme des Modelles die Funktionssicherheit.
- Betreiben Sie das Modell nur dort, wo sich keinerlei Personen oder Tiere aufhalten und eine Beschädigung anderer Güter auszuschließen ist. Handeln Sie eigenverantwortlich und überprüfen Sie das gewählte Gelände vor Inbetriebnahme des Modells auf seine Eignung.
- Betreiben Sie das Modell **NIEMALS** auf öffentlichen Straßen oder in der Nähe von Flugplätzen.
- Stoppen Sie das Modell unverzüglich bei einer Störung und beseitigen Sie sofort die Ursache.
- Berühren Sie keine rotierenden und/oder heißen Motorteile während des Betriebs oder der Abkühlphase.
- Warten Sie Ihr Modell nach jedem Einsatz und ersetzen Sie Verschleißteile, um einen sicheren Betrieb zu gewährleisten.
- Fassen Sie das Modell während und nach dem Betrieb stets so an, dass Sie keinesfalls mit Teilen des Antriebs in Berührung kommen.
- Bedenken Sie, daß Kunststoffteile bei niedrigen Außentemperaturen in Ihrer Schlagzähigkeit nachlassen können, das heißt, die Belastungsfähigkeit sinkt.
- Sofern Sie nicht über ausreichende Kenntnisse im Umgang mit Funktionsmodellen verfügen, wenden Sie sich an einen erfahrenen Modellsportler oder Modellbauclub.
- Schützen Sie sich bei Testläufen vor eventuell durch rotierende Teile aufgewirbelten Schmutz bzw. Steinchen.
- Schützen Sie alle elektrischen Komponenten vor Wasser und Fremdkörpern.
- Sorgen Sie dafür, dass der Motor nicht überlastet oder blockiert wird.
- Lassen Sie den Motor und den Akku nach dem Betrieb ausreichend abkühlen.
- Laden und entladen Sie Ihre Akkus sorgfältig und achten Sie darauf, dass Akkus und Anschlusskabel keinerlei Beschädigungen aufweisen.
- Schließen Sie den Akku niemals "kurz" durch Zusammenführen des Plus- und Minuspols.
- Verlegen Sie die Kabel im und am Modell so, dass diese nicht in oder an rotierende oder heiße Teile geraten.

2. SICHERHEITSHINWEISE / SAFETY INSTRUCTIONS

GENERAL SAFETY INSTRUCTIONS FOR ELECTRIC MODELS













- This is not a toy! Suitable for young people under the age of 14 with adult supervision.
- Use the model accordingly to chapter "How To Use" in this instruction manual.
- Assemble the model accordingly to this instruction manual. Do not alter or modify the model. Only use parts that are officially recommended by extron Modellbau.
- Always pay close attention to the manuals that are included to accessory parts (radio system, speed controller, battery etc.).
- Do not fly the model before you have finished the assembly completely according to this manual.
- Before you fly, check all functions of the model carefully.
- Never fly your model near other human beings, animals or other obstacles. You are responsible for flying the model, so you have to check carefully your flight area.
- **NEVER** use your model on public streets or near public airports.
- Stop flying immediately if you realize any radio interference.
- Do not touch any moving or hot motor parts during action! Let all components cool down before you handle them.
- Check your model carefully after each flight. Replace parts if they are worn out or if they are defective.
- Keep your hands out of reach from rotating or hot parts of the model.
- Keep in mind that plastic parts easily break under cold temperature conditions.
- If you are a novice in flying you should ask experienced pilots for assistance during your first flights.
- Protect yourself from dust and other small things when you test run your propeller drive on the ground.
- Keep all electronic components dry and clean!
- Take care that your motor does not get overload or gets blocked under full power.
- Let the motor cool down after restarting the model again.
- **Charge your batteries carefully. Always observe charging process.**
- Do not shorten the battery by connecting the pluspole with the minuspole directly!
- Make sure that the wires do not touch rotating or hot parts of the model.

siehe www.shop.pichler.de

check www.shop.pichler.de

4. MONTAGE / ASSEMBLY

ERKLÄRUNG DER SYMBOLE / EXPLANATION OF SYMBOLS

 Überschuss abschneiden! Cut off excess!	 Schraubensicherung verwenden! Use Screw Cement!	 Nicht im Lieferumfang enthalten! Not included!
 Markierte Fläche abschneiden! Cut the marked area!	 Mit Sekundenkleber verkleben! Use Cyano Glue!	 Auf Leichtgängigkeit achten! Move freely, NO binding!
 Genau beachten! Notice!	 Mit Epoxydharz verkleben! Use Epoxy Glue!	 Loch bohren mit dem dargestellten Durchmesser. Drill a hole with the shown diameter
 Achtung! Attention!	 Eine linke und eine rechte Seite bauen! Build a left and a right side!	 Vorgang x-mal wiederholen. Repeat this step.

 **Warning!** ▶ Schrauben gut festziehen! Falls sich die Verbindung im Flug löst, gerät das Modell außer Kontrolle!
Set all screws securely. If they come off during flight, you will lose control of the aircraft.

WERKZEUGE / TOOLS

Für die Montage benötigen Sie das nebenstehende Werkzeug und Klebstoff (nicht im Lieferumfang enthalten).

For assembly, you will need the shown tools and glue (not included).

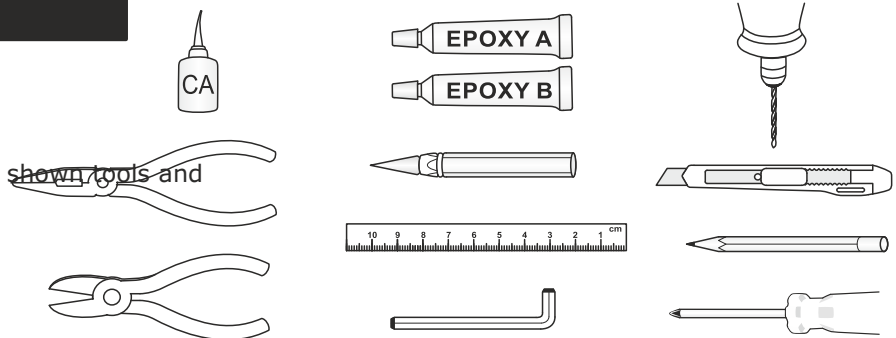

- 1: Fuselage set(1a: Canopy; 1b: Hatch). 2 : Wing set .
 3: Horizontal stabilizer & Vertical stabilizer set. 4: Nose gear set .5: Main gear set.6: Cowling set.
 7: Fuel tank set.8: Engine set.9: Electric motor set. 10: Spinner set. 11: CG set.

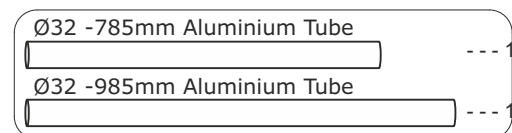
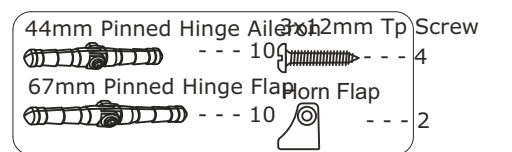
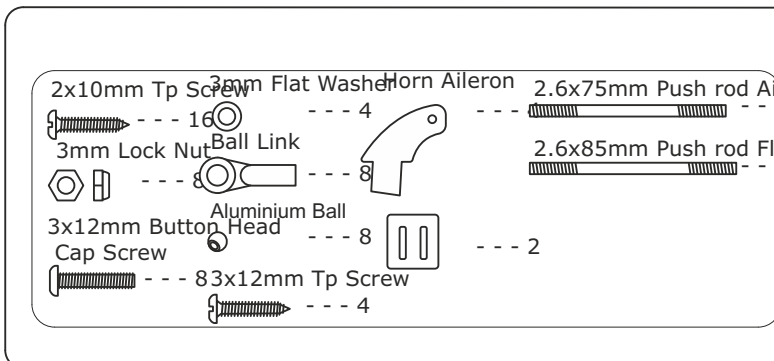
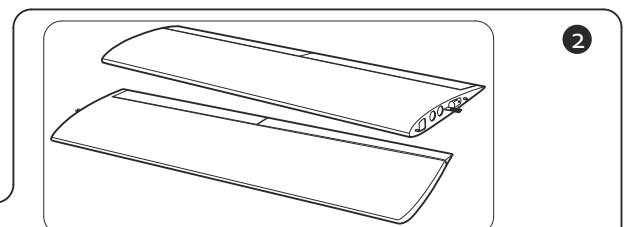
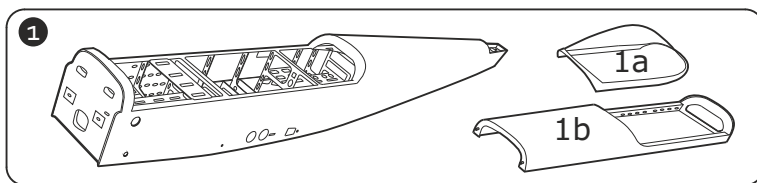

4. MONTAGE / ASSEMBLY

2

- Horn
- Ball Link
- 2.6x40mm Push rod Rudder
- 3mm Lock Nut
- 44mm Pinned Hinge
- 2x10mm Tp Screw
- 2.6x50mm Push rod Elevator
- 3mm Hex Nut
- 44mm Pinned Hinge
- 4x30mm Plastic Screw
- Aluminium Ball
- 3x12mm Button Head Cap Screw
- M3 Clevis
- 3x25mm Socket Head Cap Screw
- 5mm Flat Washer
- 3x40mm Socket Head Cap Screw
- 3mm Lock Nut
- Plastic Strut Attachment
- 3x6mm Button Head Cap Screw
- 5mm Strut Attachment
- 42° Aluminium Strut Attachment
- 146mm Aluminium Strut
- 6x45mm Plastic Screw

3

- 100mm Wheel
- Horizontal Strut
- Main Strut
- 4 x 25 mm Socket Head Cap Screw
- 4mm Spring Washer
- 4 x 12 mm Flat Washer
- 4 x 12 mm Socket Head Cap Screw
- Lock Tube
- 600mm Cable Rod
- 3 x 12 mm Button Head Cap Screw
- 3mm Flat Washer
- Ball Link
- Aluminium Ball
- 3mm Lock Nut

4

- Main gear
- 127mm Wheel
- 5x25mm Socket Head Cap Screw
- 5mm Spring Washer
- 6mm Flat Washer
- 6mm Socket Head Lock Nut
- 6mm Plastic Washer
- Cowling
- 3x12mm Tp Screw

5

- Stopper
- Fuel Tank
- Clunk
- Plate of Plywood
- 3x12mm Tp Screw

6

- Motor
- Connector
- Throttle Pushrod
- Plate of plywood

7

- 5x60mm Socket Head Cap Screw
- 5mm Flat Washer
- 5mm Spring Washer
- 12x30mm Aluminium Tube
- 5mm Lock Nut

8

- Spinner Cap
- Back Plate
- 3x12mm Tp Screw

9

- 6 x 25mm Plastic Screw
- Plate of plywood
- Ø 12x100mm Aluminium Tube
- 2000mm Wire

4. MONTAGE / ASSEMBLY

QUERRUDER / AILERONS & FLAP

44mm Pinned Hinge Aileron --- 10
 3x12mm Tp Screw --- 4
 67mm Pinned Hinge Flap --- 10
 Horn Flap --- 2

ANSICHT VON UNTEN
 BOTTOM VIEW

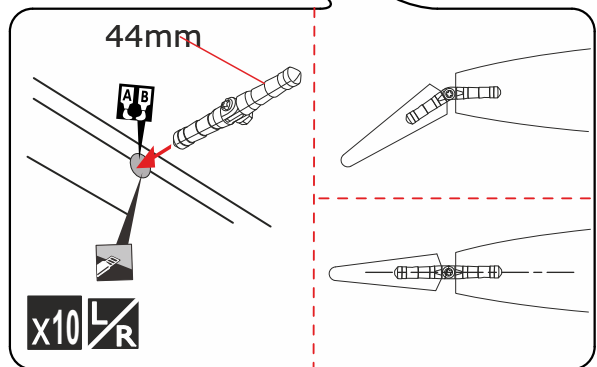
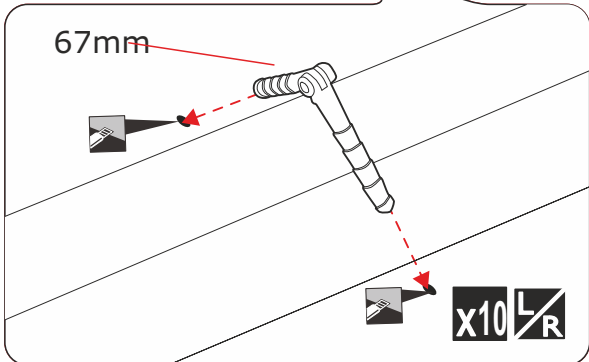
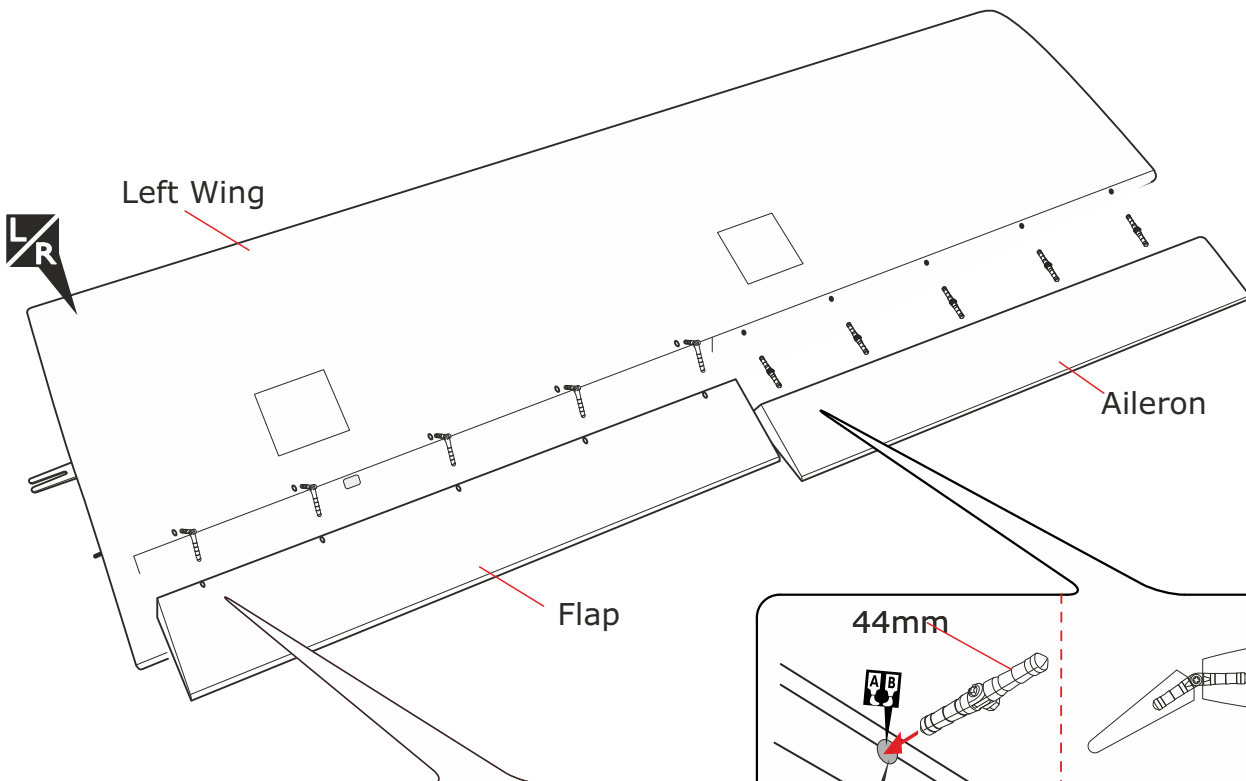
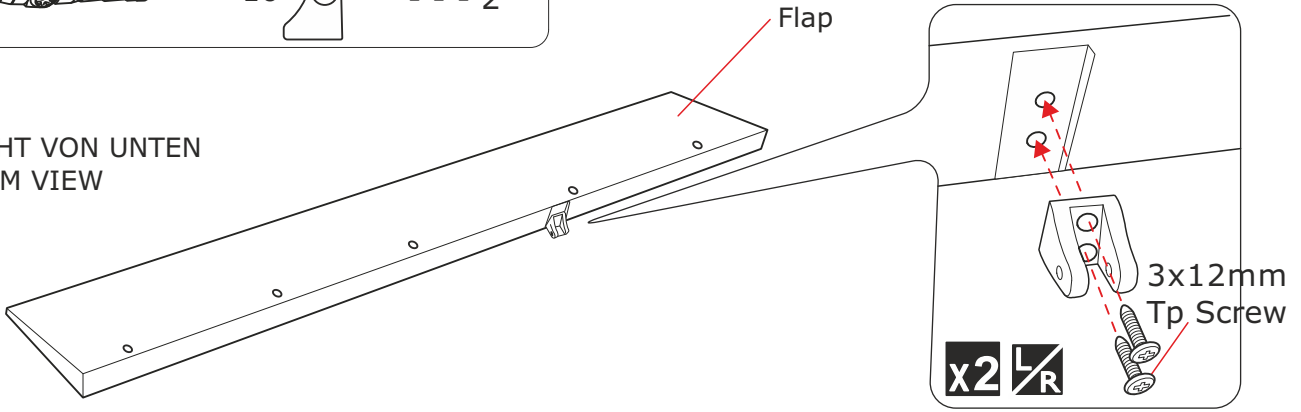

QUERRUDER SERVOS / AILE

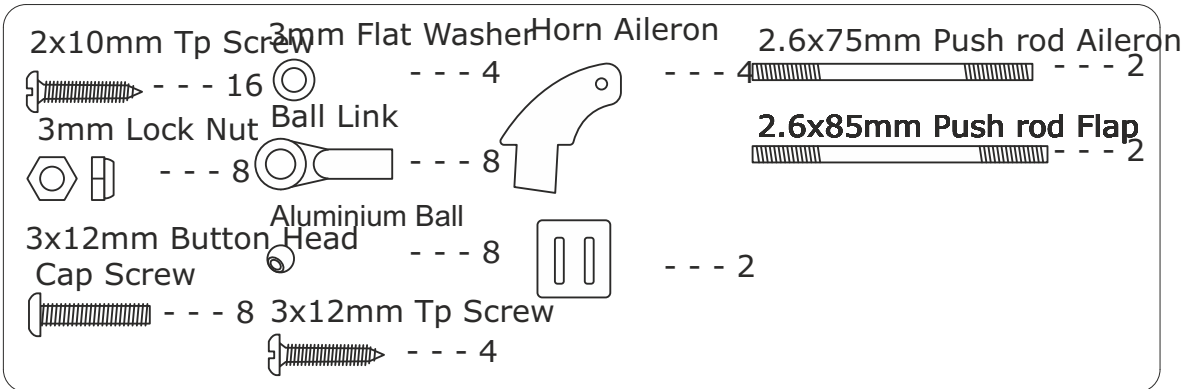
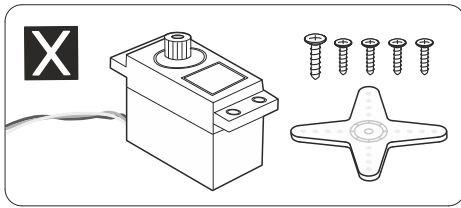

ANSICHT VON UNTEN
BOTTOM VIEW

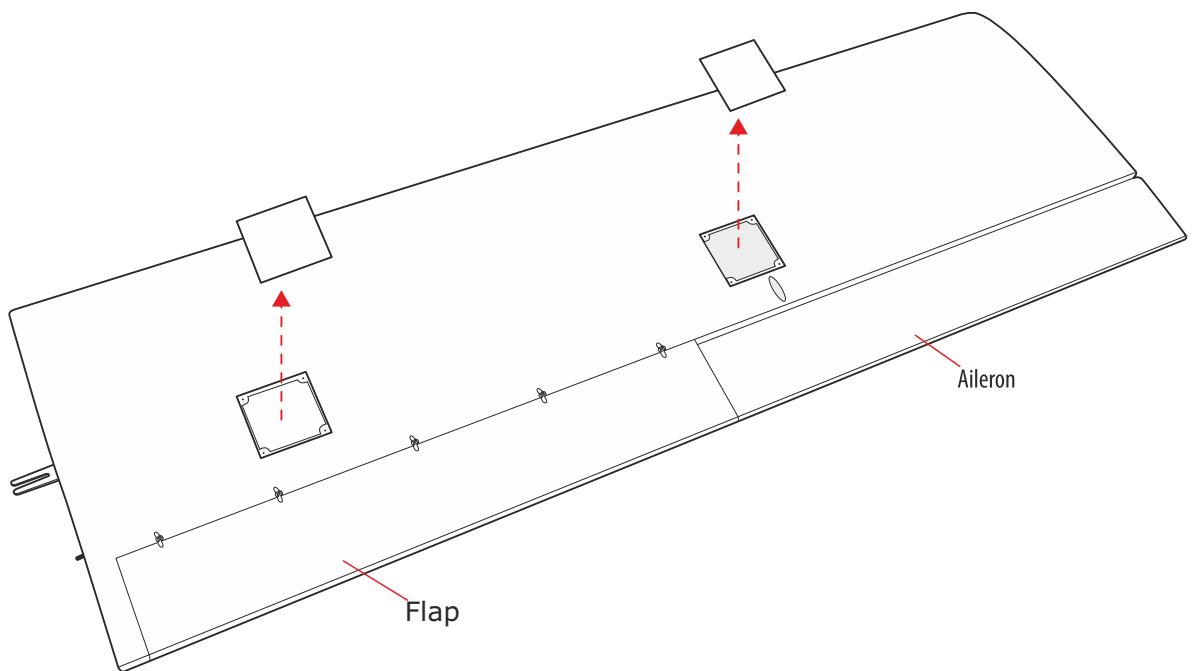

4. MONTAGE / ASSEMBLY

For Aileron Servo

X2

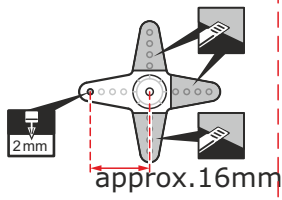

X2

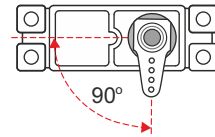
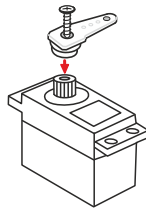

X2 **L/R**

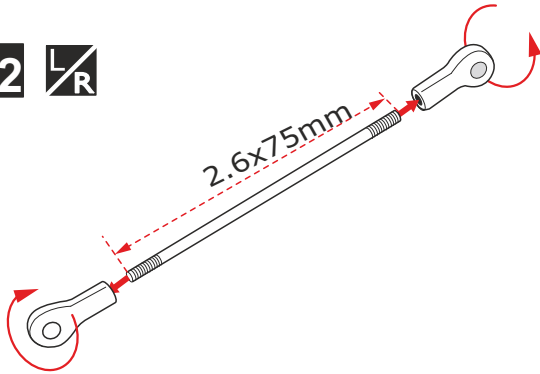

X2 **L/R**

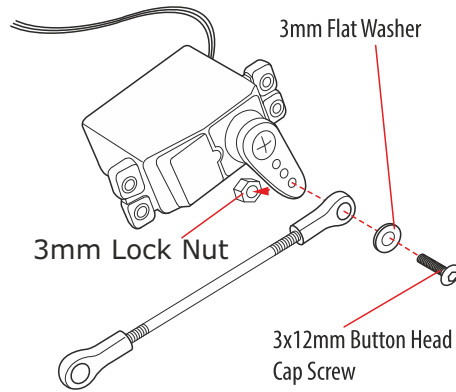

X2 **L/R**

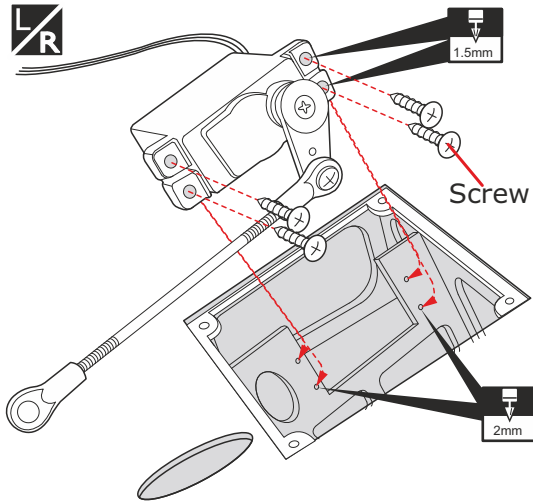

X2 **L/R**

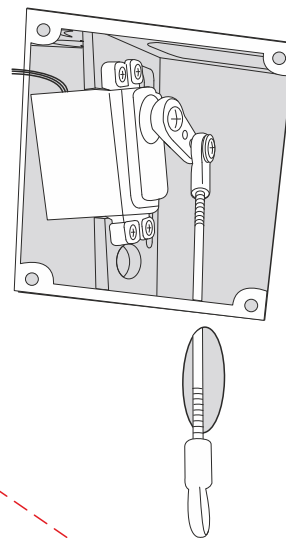

X2 **L/R**

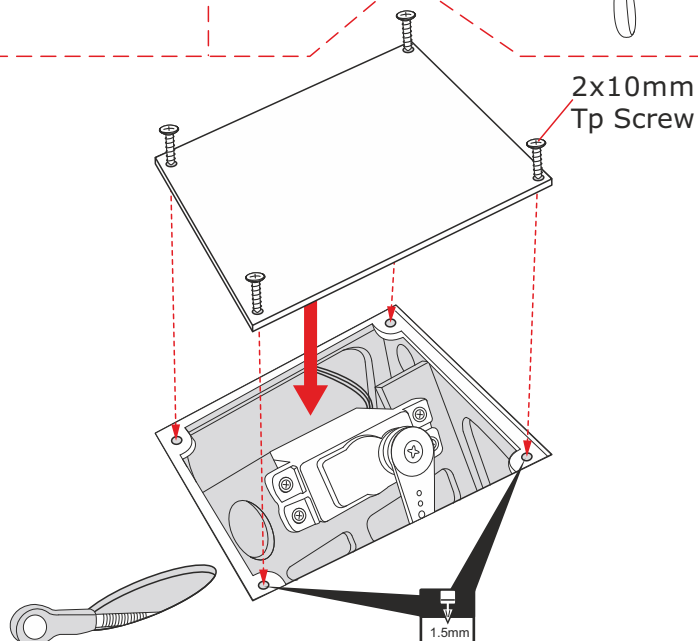

For Flap Servo

x2

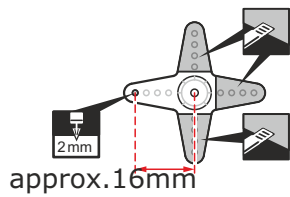

x2

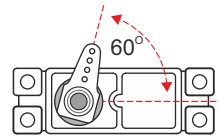
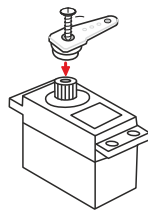

x2 L/R

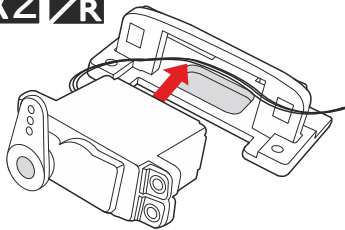

x2 L/R

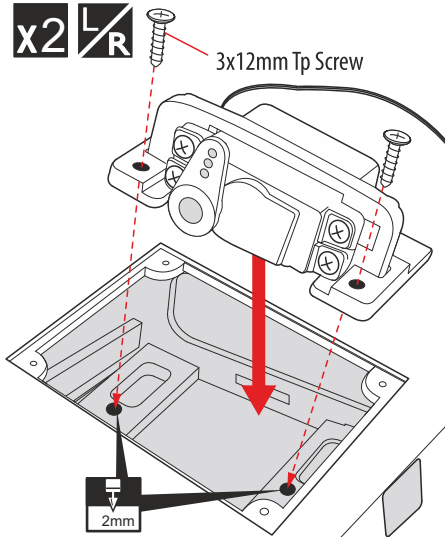

x2 L/R

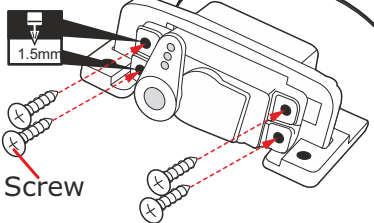
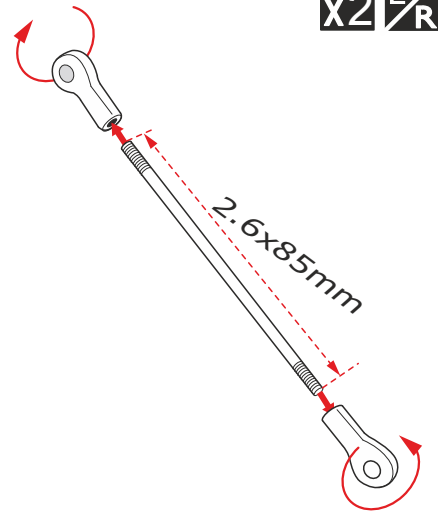

x2 L/R

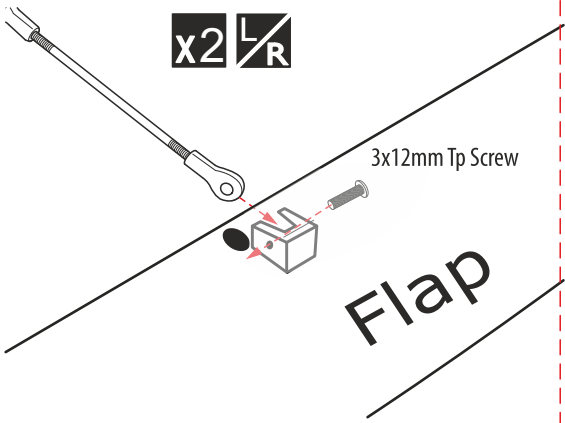

x2 L/R

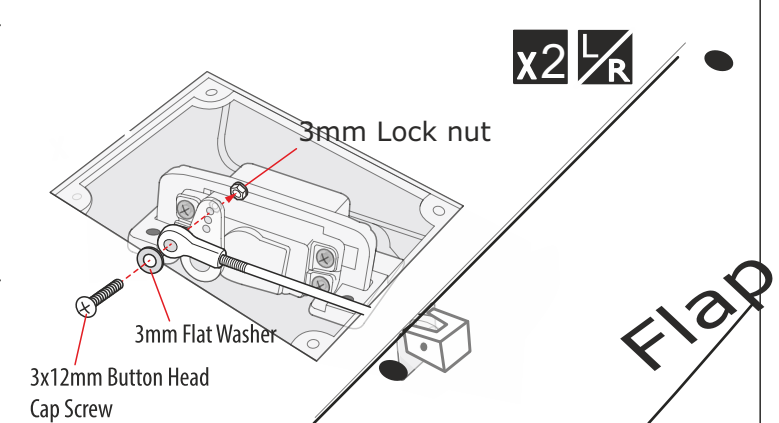

x2 L/R

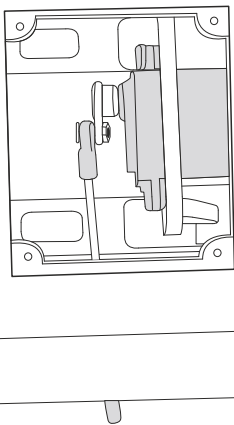

2x10mm Tip Screw

x2 L/R

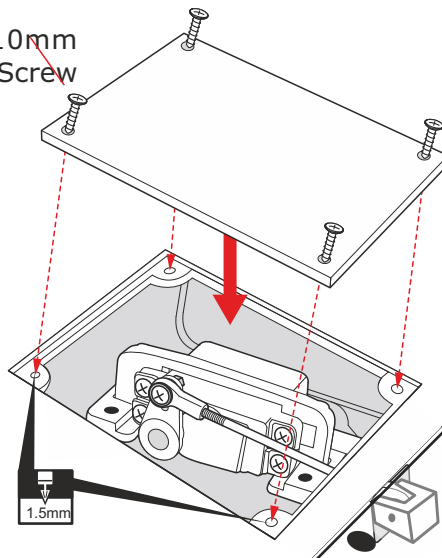

4. MONTAGE / ASSEMBLY



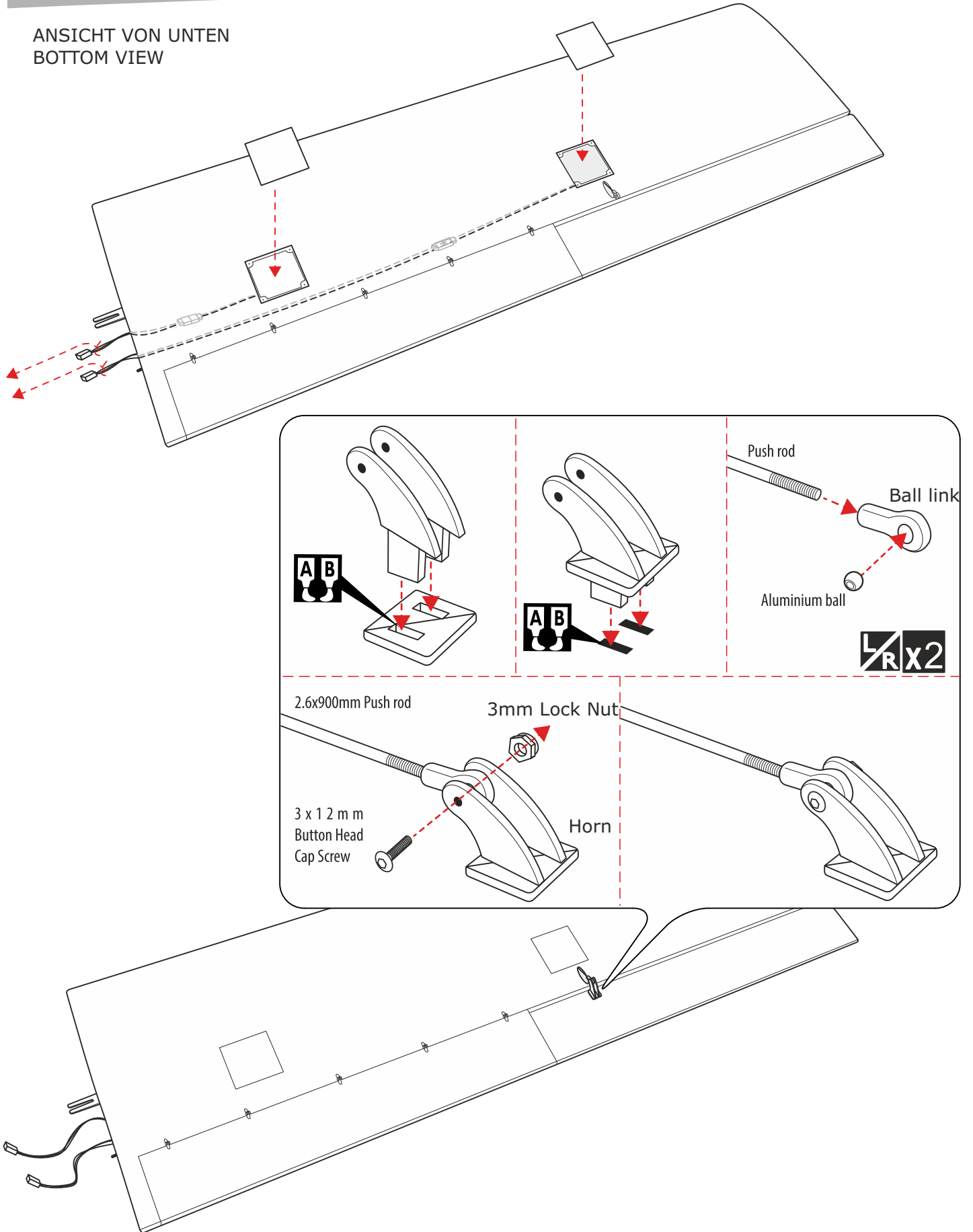



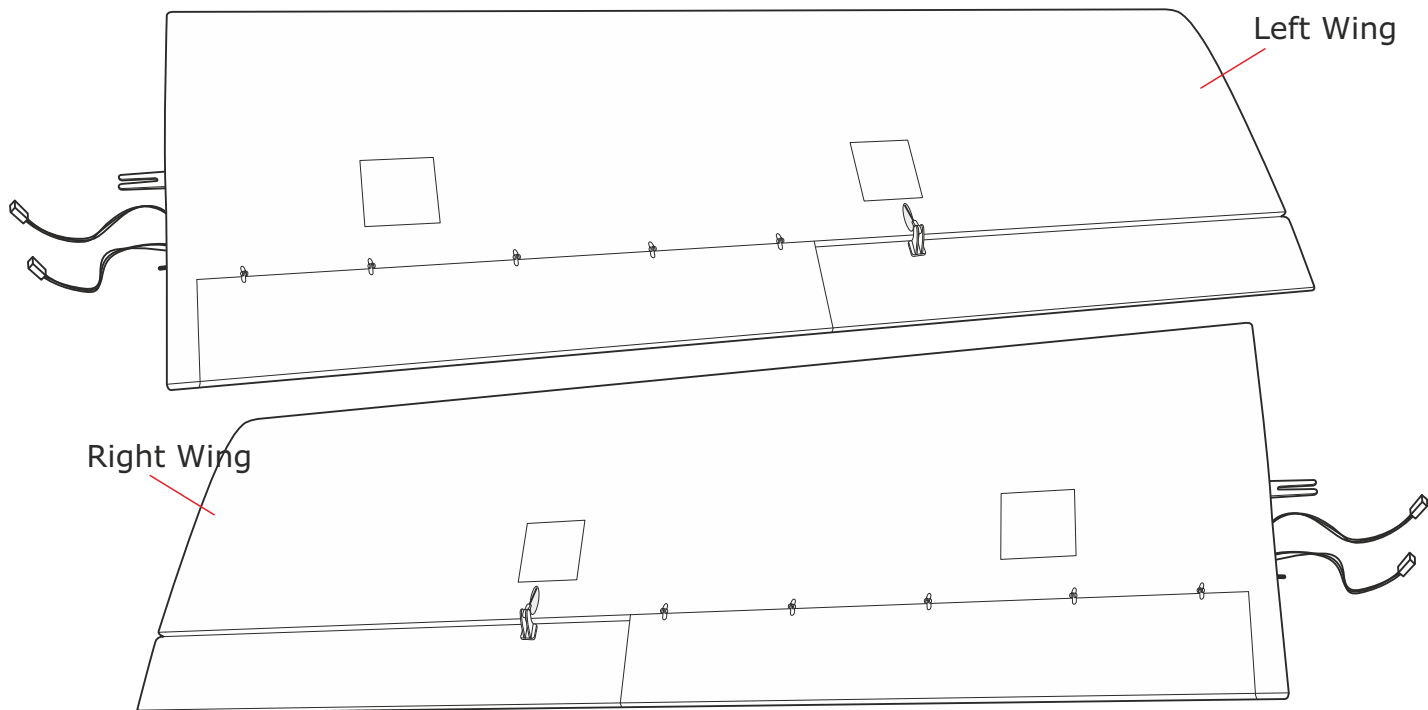

ANSICHT VON UNTEN
BOTTOM VIEW

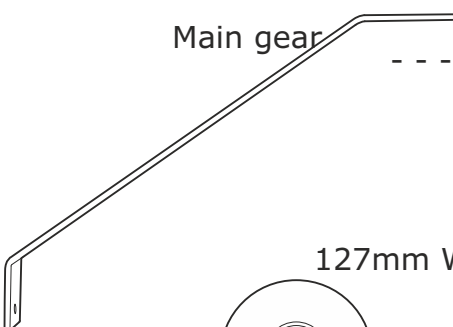

ANSICHT VON UNTEN
BOTTOM VIEW

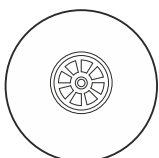

Fahwerk / Main Gear

 <p>Main gear --- 2</p>	 <p>5x25mm Socket Head Cap Screw --- 6</p>	 <p>6x60mm Socket Head Cap Screw --- 2</p>	
	 <p>5mm Spring Washer --- 6</p>	 <p>6mm Flat Washer --- 8</p>	
	 <p>127mm Wheel --- 2</p>	 <p>5mm Flat Washer --- 6</p>	 <p>6mm Hex Nut --- 4</p>
			 <p>6mm Plastic Washer --- 2</p>

4. MONTAGE / ASSEMBLY



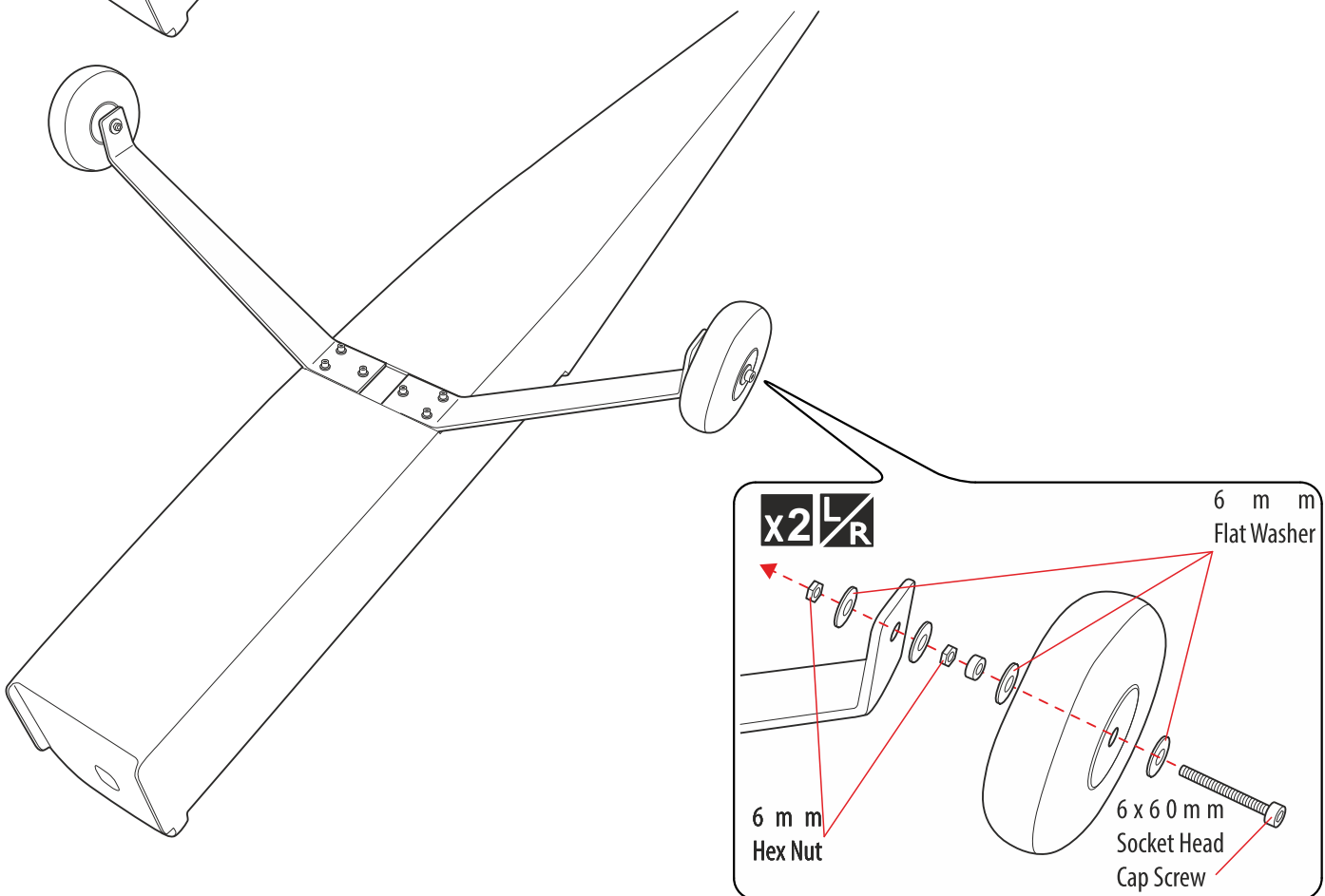
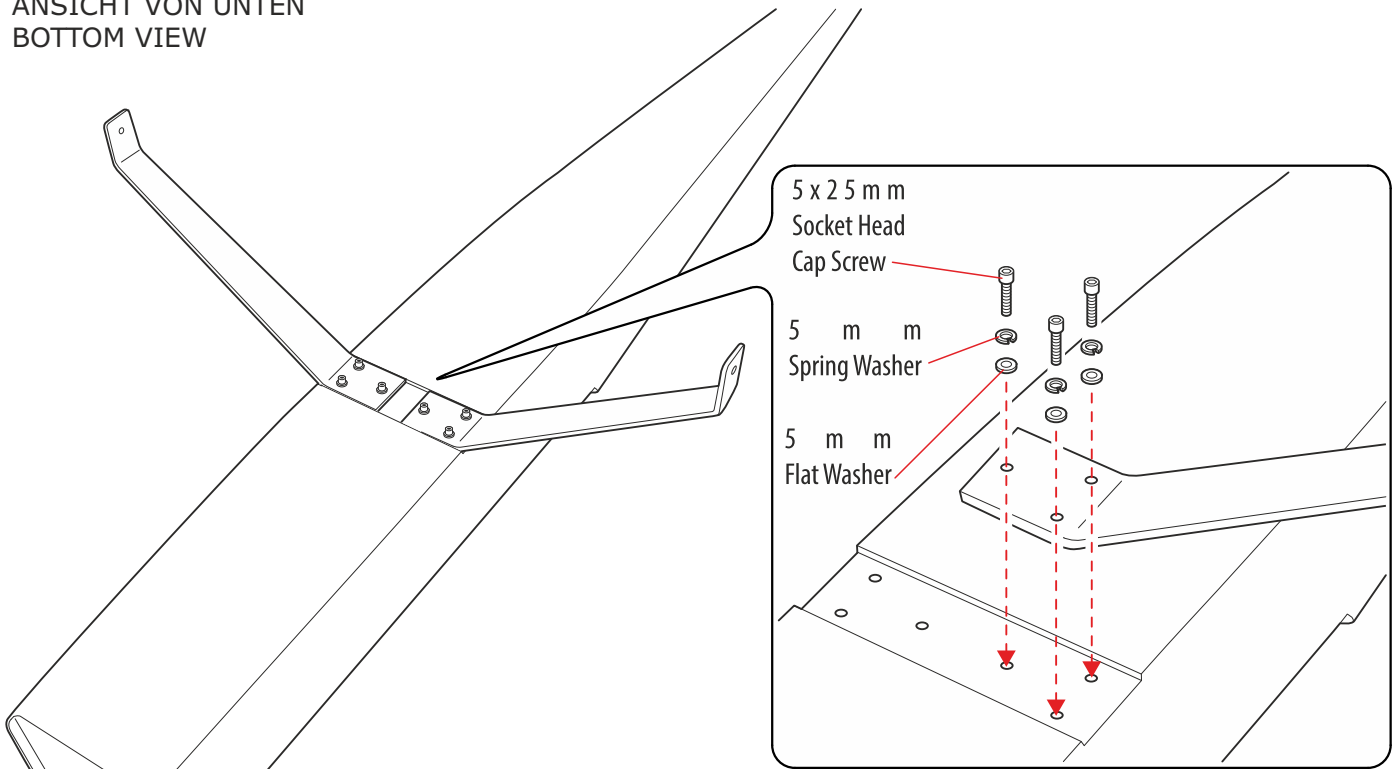



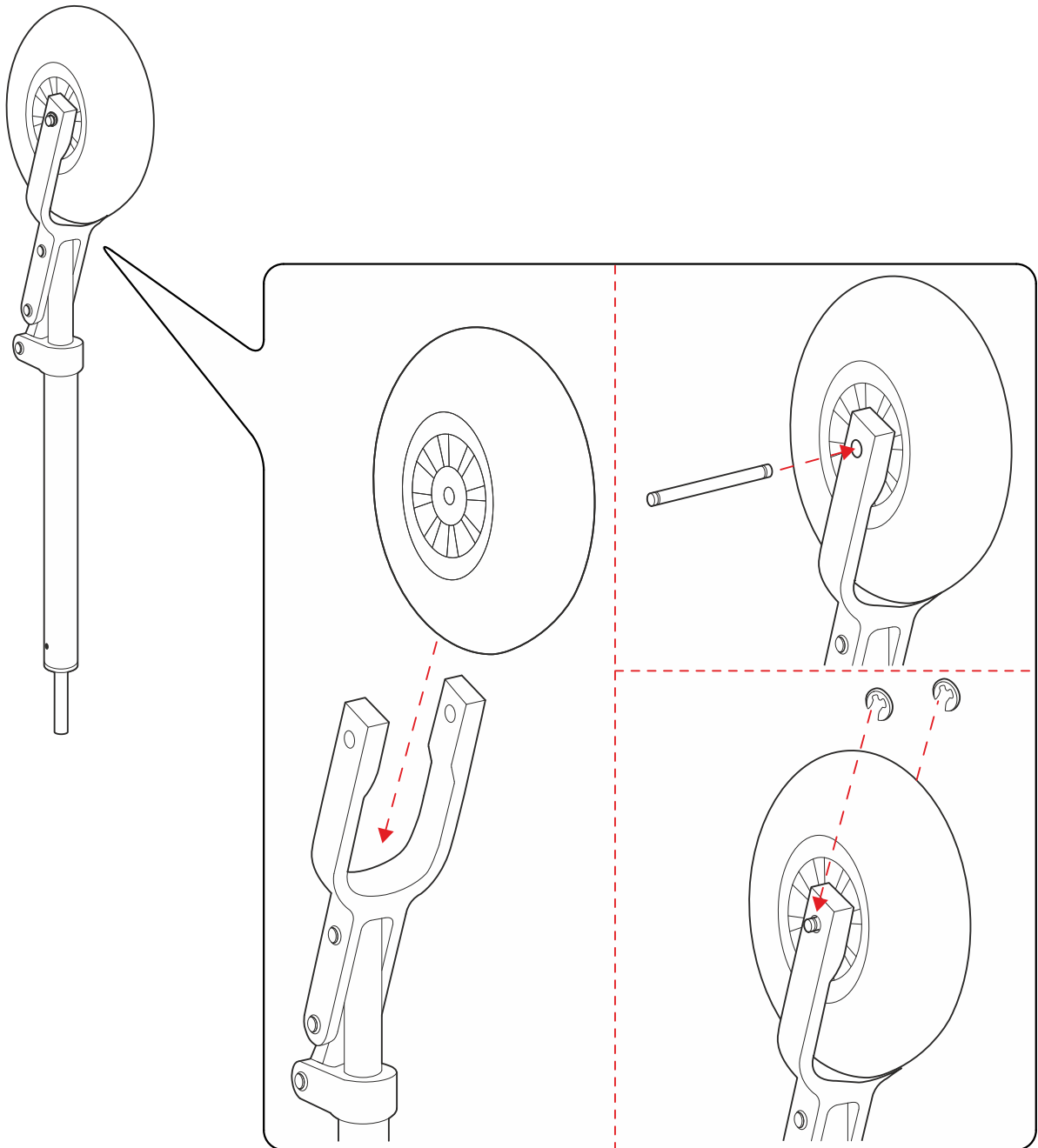
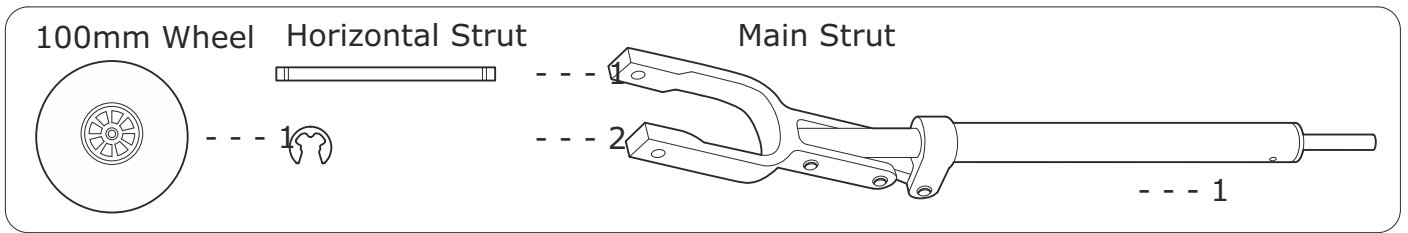





ANSICHT VON UNTEN
BOTTOM VIEW



Bugfahrwerk / Nose Gear

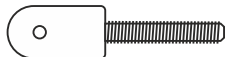
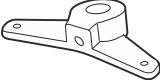

4. MONTAGE / ASSEMBLY

- | | |
|--|---|
| 4 x 25 mm Socket Head Cap Screw | 3 x 12 mm Button Head Cap Screw |
|  - - - 4 |  - - - 2 |
| 4mm Spring Washer | 3mm Flat Washer |
|  - - - 4 |  - - - 2 |
| 4mm Flat Washer | Ball Link |
|  - - - 4 |  - - - 2 |
| 4 x 12 mm Socket Head Cap Screw | Aluminium Ball |
|  - - - 1 |  - - - 2 |
| Lock Tube | 3mm Lock Nut |
|  - - - 4 |  - - - 2 |
|  - - - 2 |  - - - 2 |
|  - - - 1 | |
| 600mm Cable Rod | |
|  - - - 2 | |

ANSICHT VON UNTEN
BOTTOM VIEW

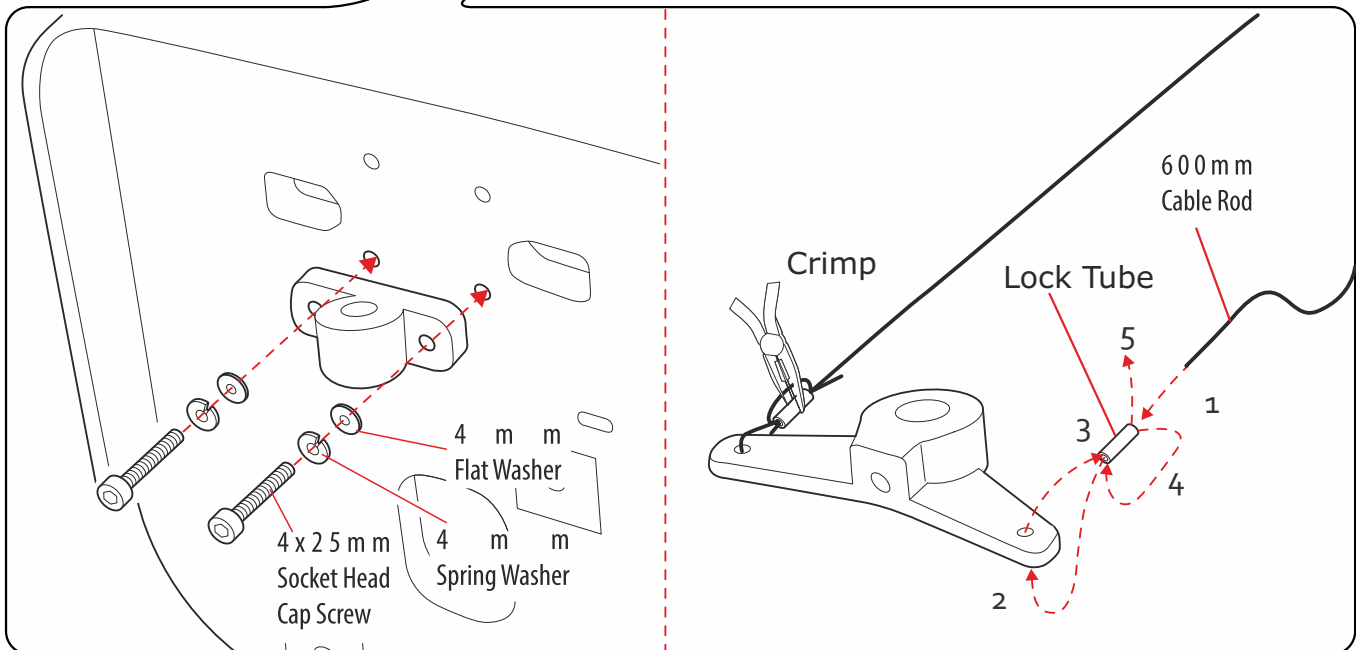
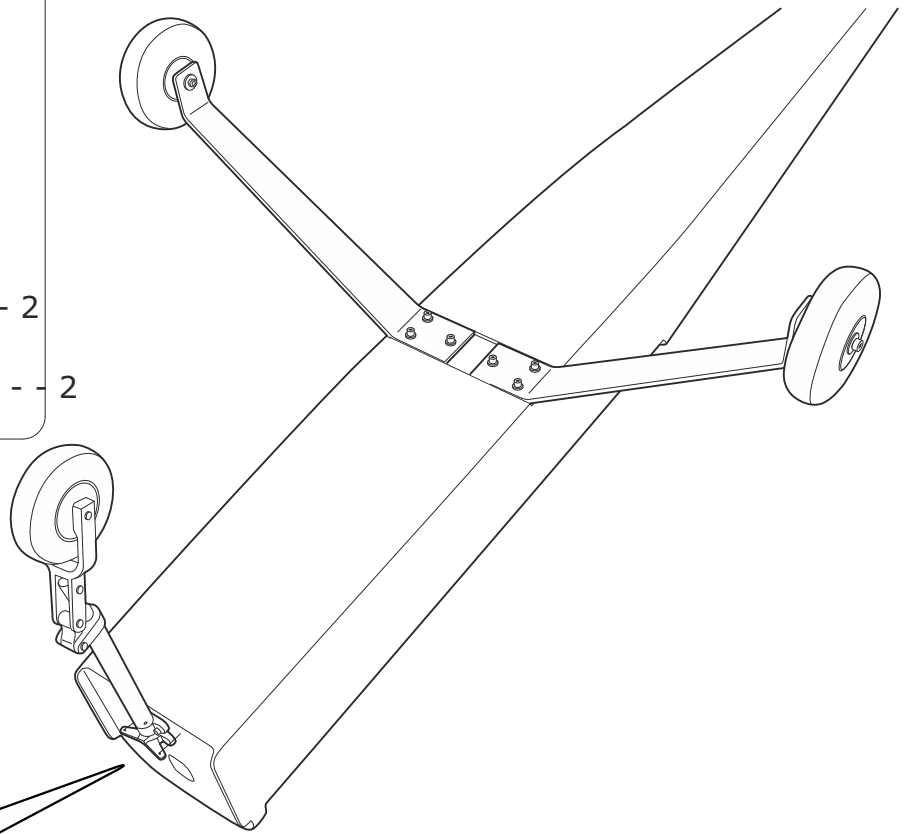

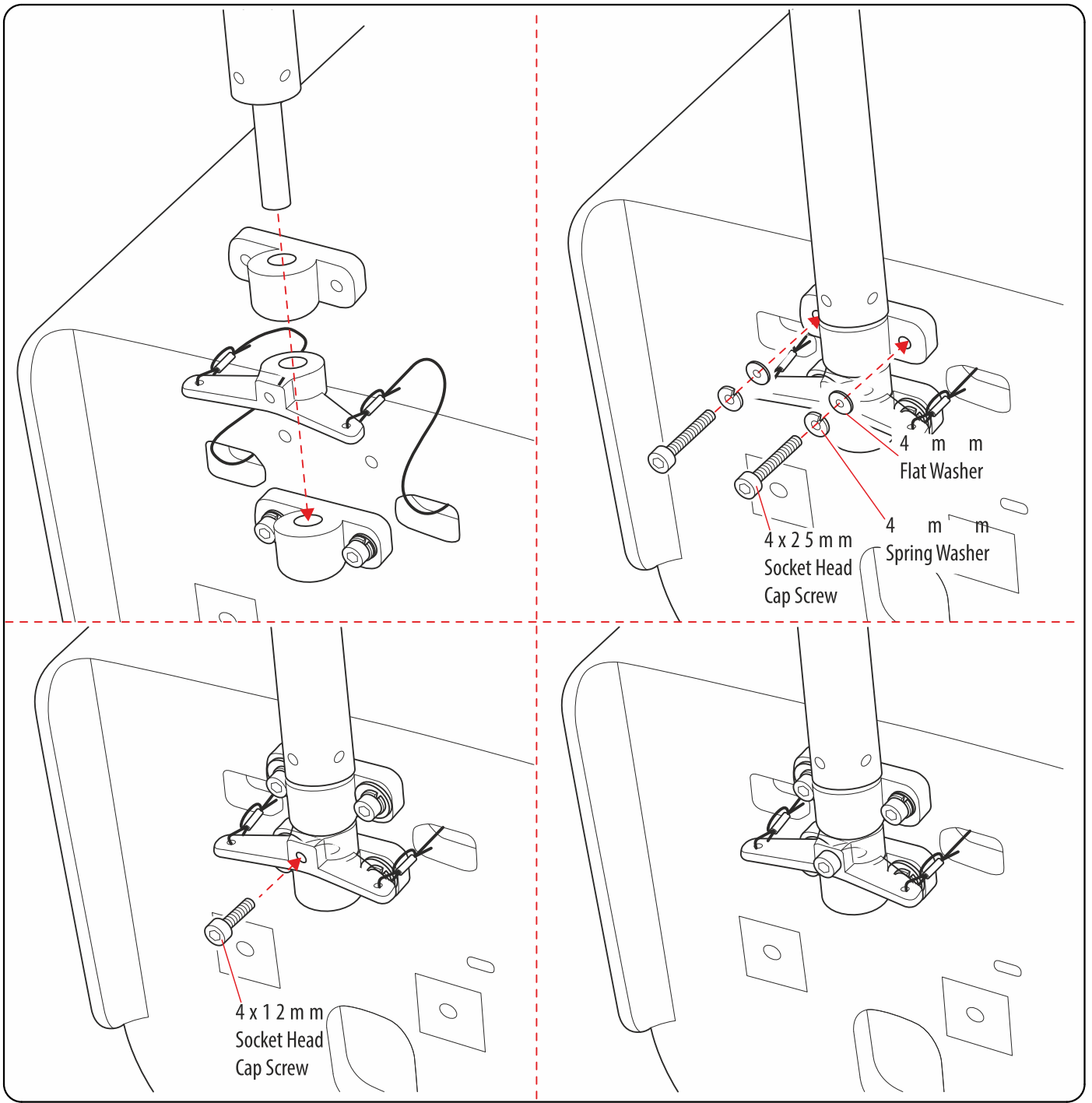

4. MONTAGE / ASSEMBLY

For Nose Gear Servo

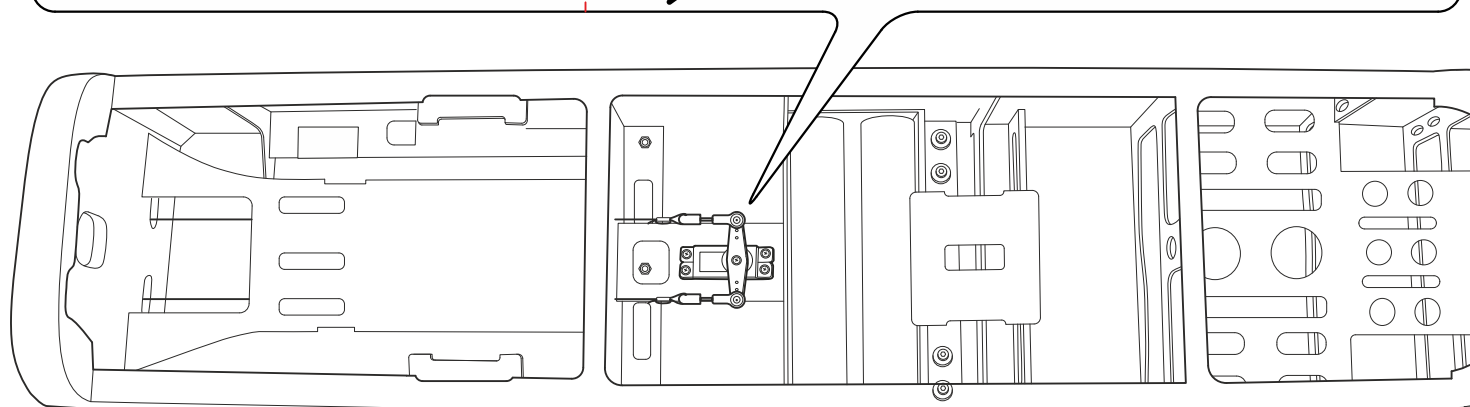
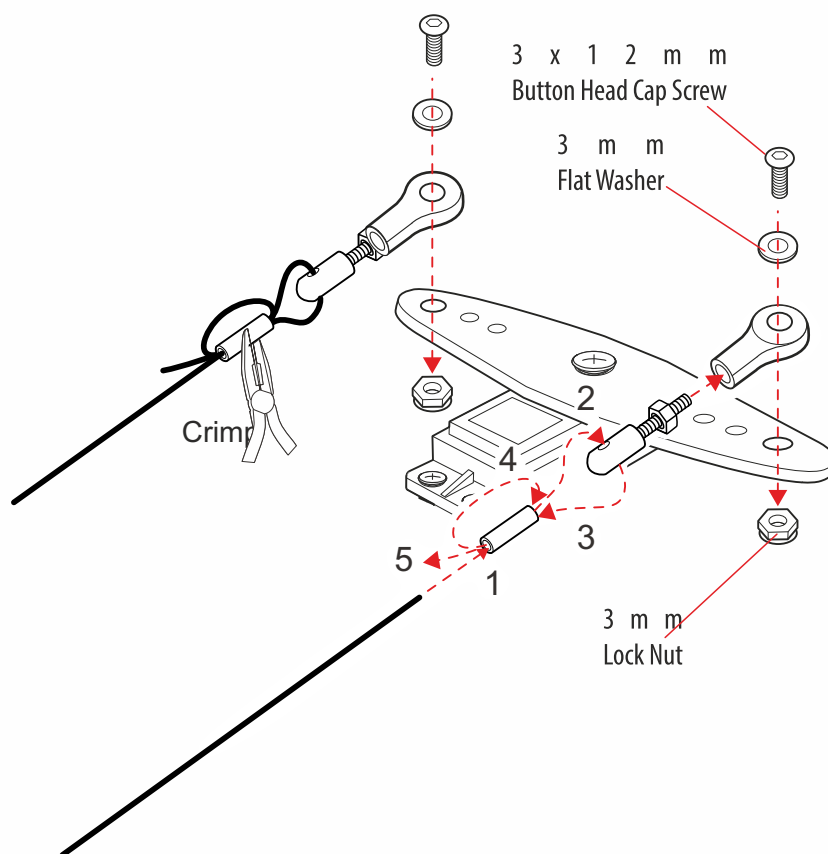
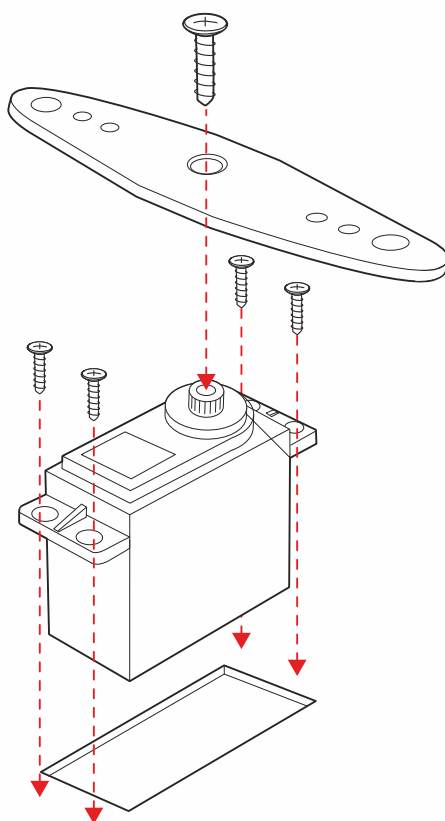
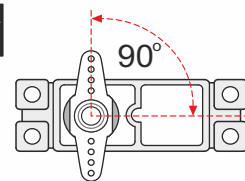
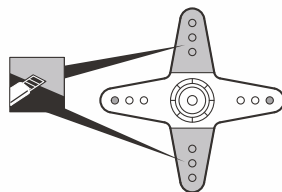
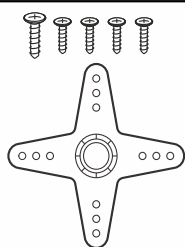
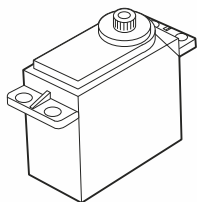

Höhenleitwerk, Seitenleitwerk / Horizontal, Vertical Stabilizer

44mm Pinned Hinge



--- 6

2x10mm Tp Screw

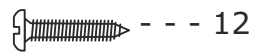

--- 12

ANSICHT VON UNTEN
BOTTOM VIEW

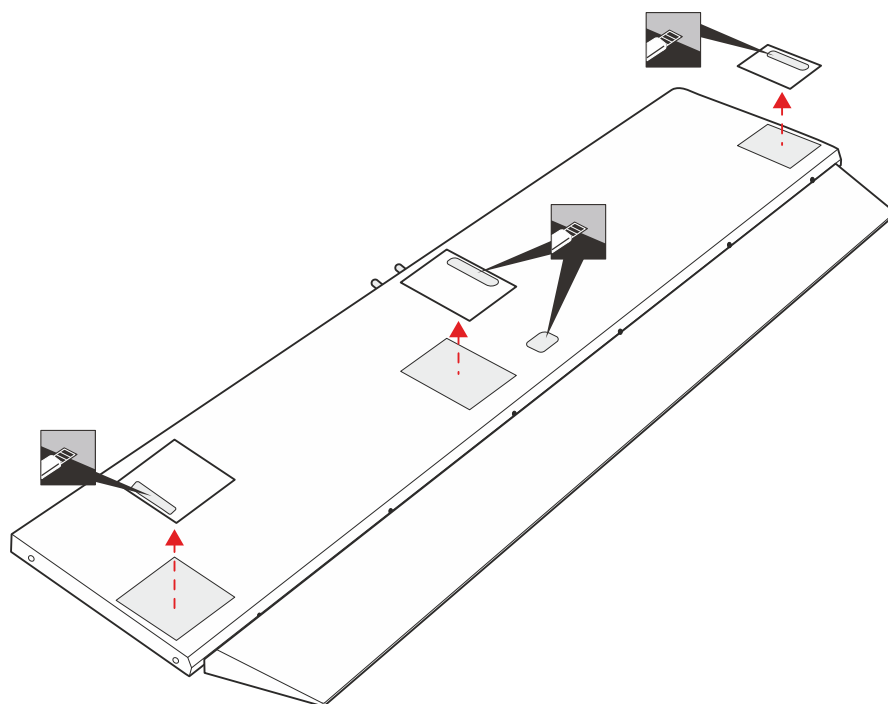
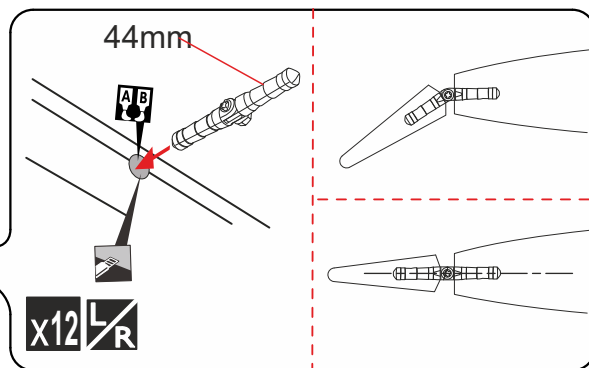
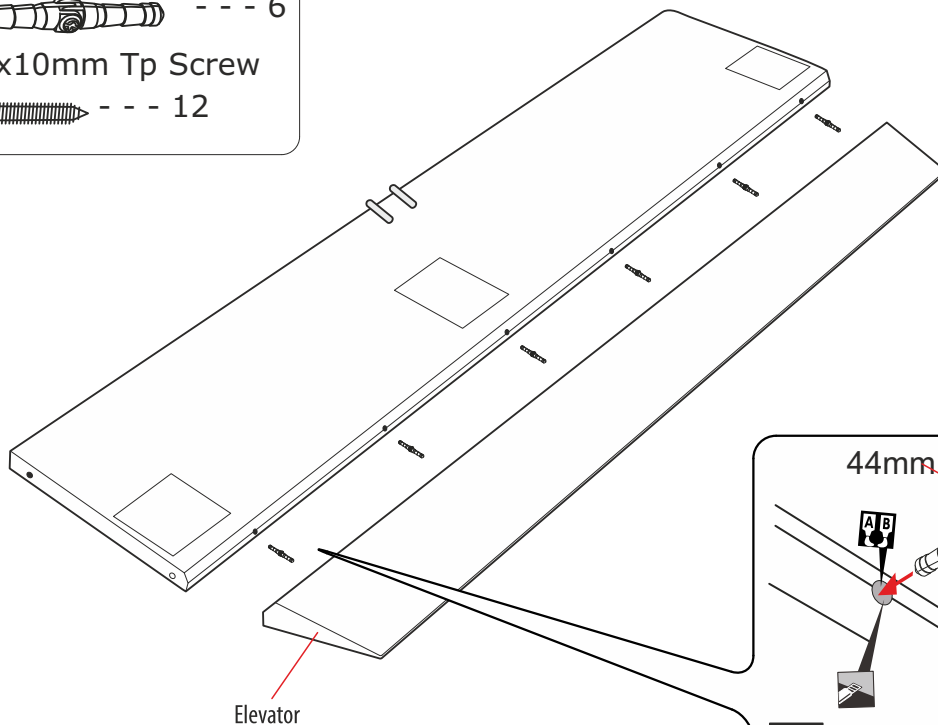

4. MONTAGE / ASSEMBLY

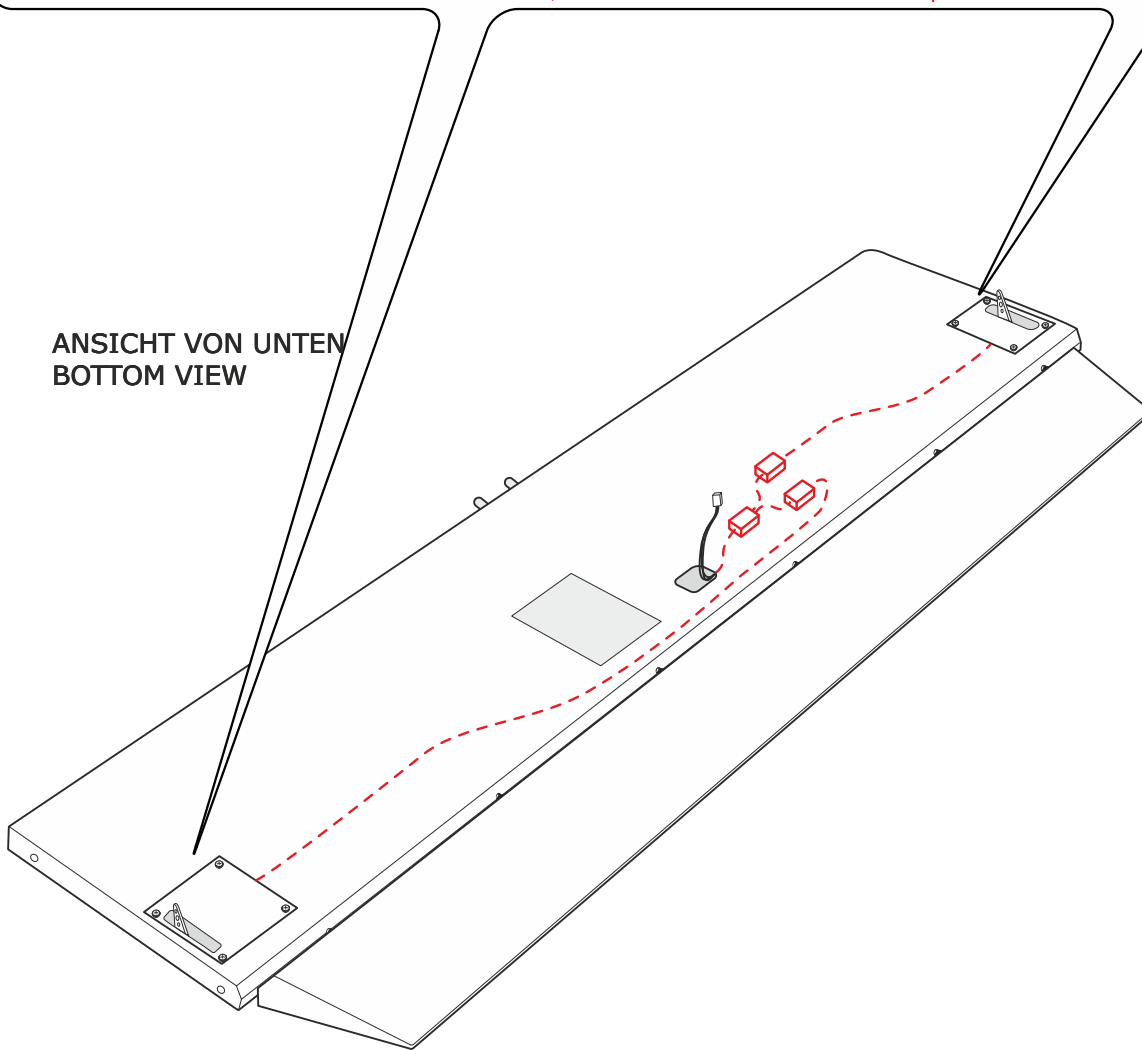
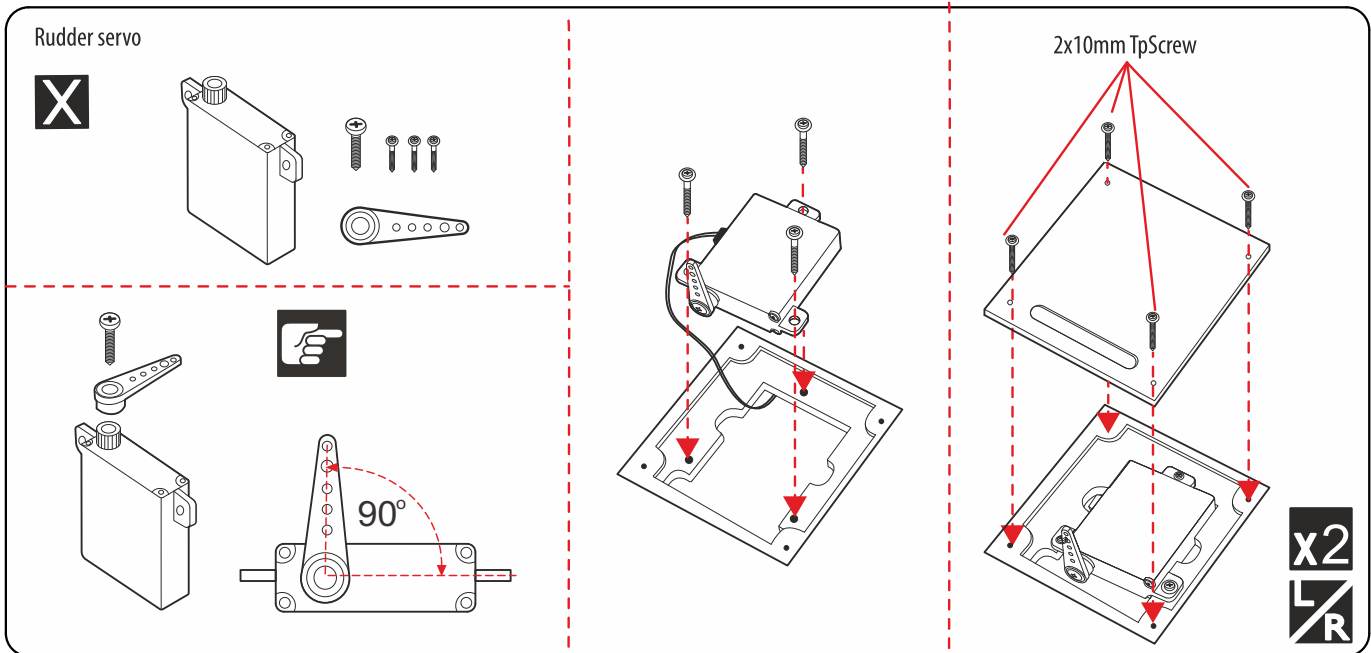





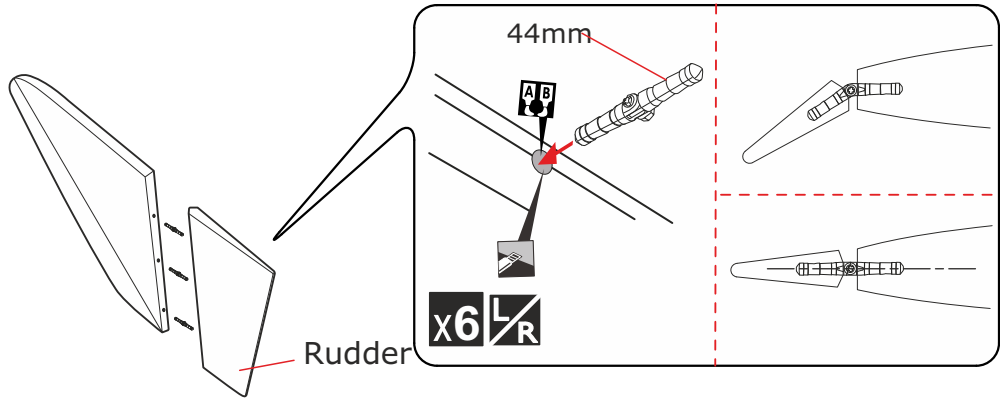

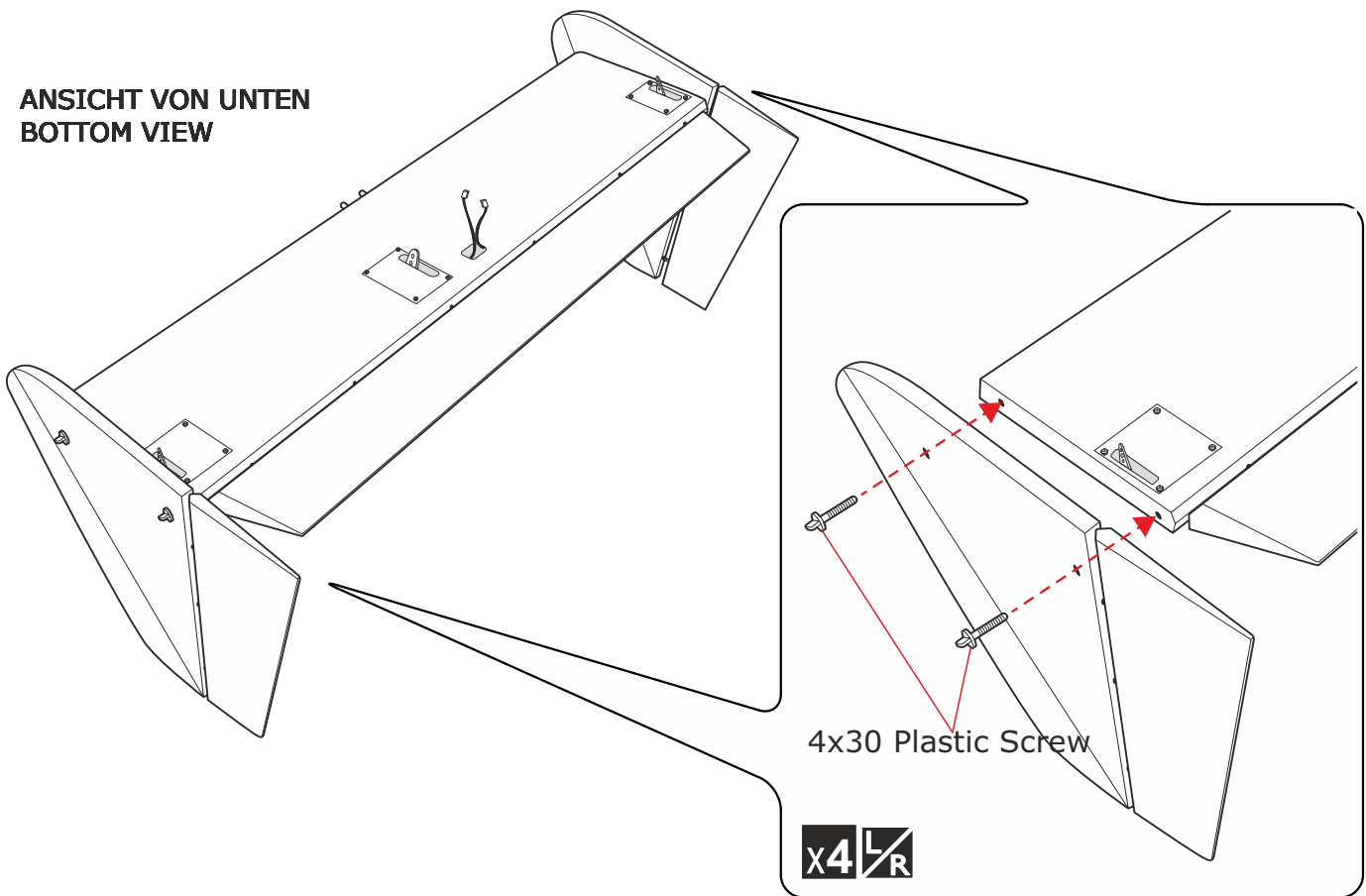

4. MONTAGE / ASSEMBLY

- 44mm Pinned Hinge --- 6
- 4x30mm Plastic Screw --- 4

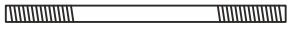

ANSICHT VON UNTEN
BOTTOM VIEW

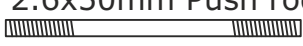

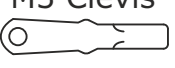
- | | | | |
|---|---|---|---|
| Horn --- 6 | Ball Link --- 4 | 2.6x40mm Push rod Rudder --- 2 | 3mm Lock Nut --- 4 |
|  |  |  |  |
| Aluminium Ball --- 3 | Aluminium Ball --- 4 | 2.6x50mm Push rod Elevator --- 1 | 3mm Hex Nut --- 2 |
|  |  |  |  |
| | 3x12mm Button Head Cap Screw --- 4 | M3 Clevis --- 2 | |
| |  |  | |

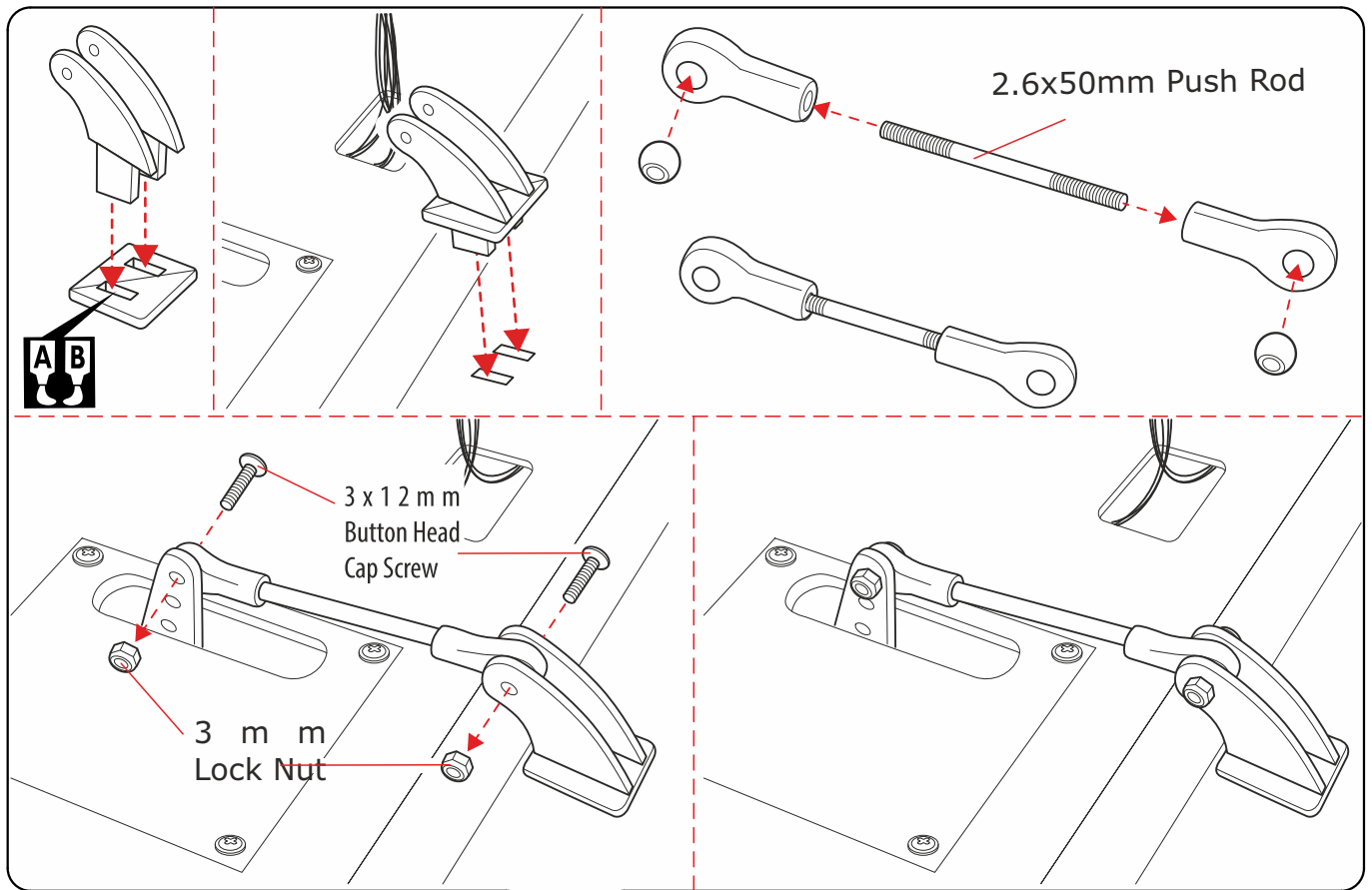

ANSICHT VON UNTEN
BOTTOM VIEW

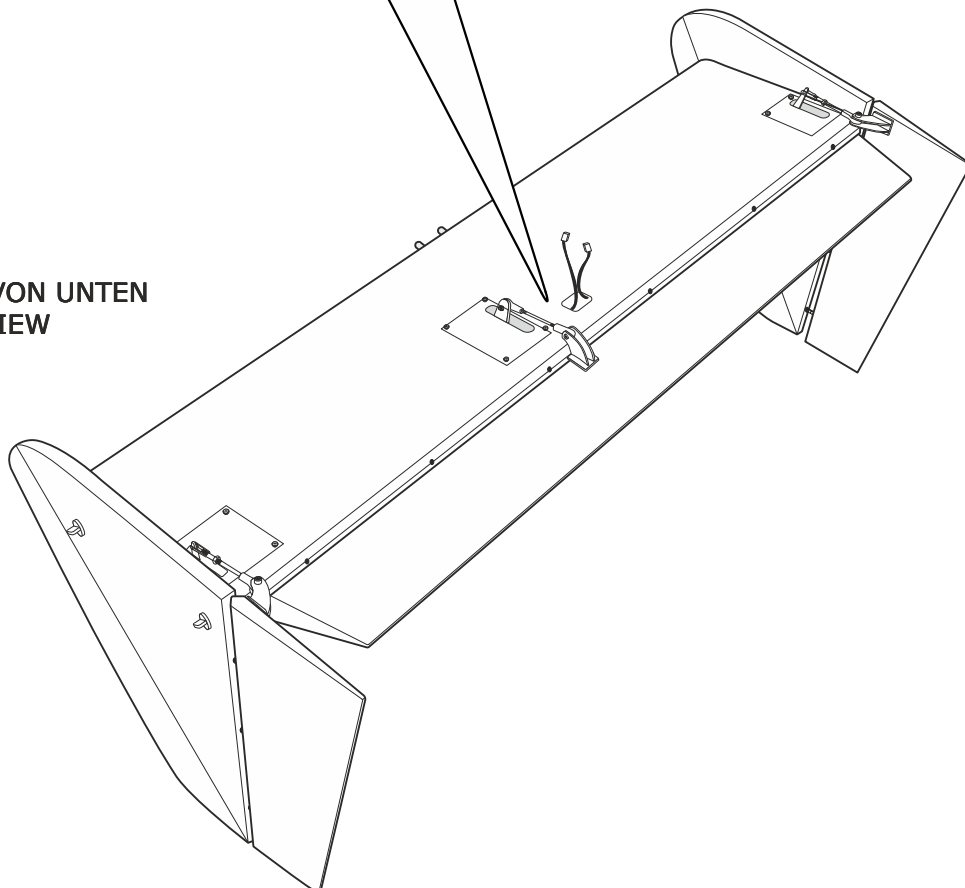

4. MONTAGE / ASSEMBLY

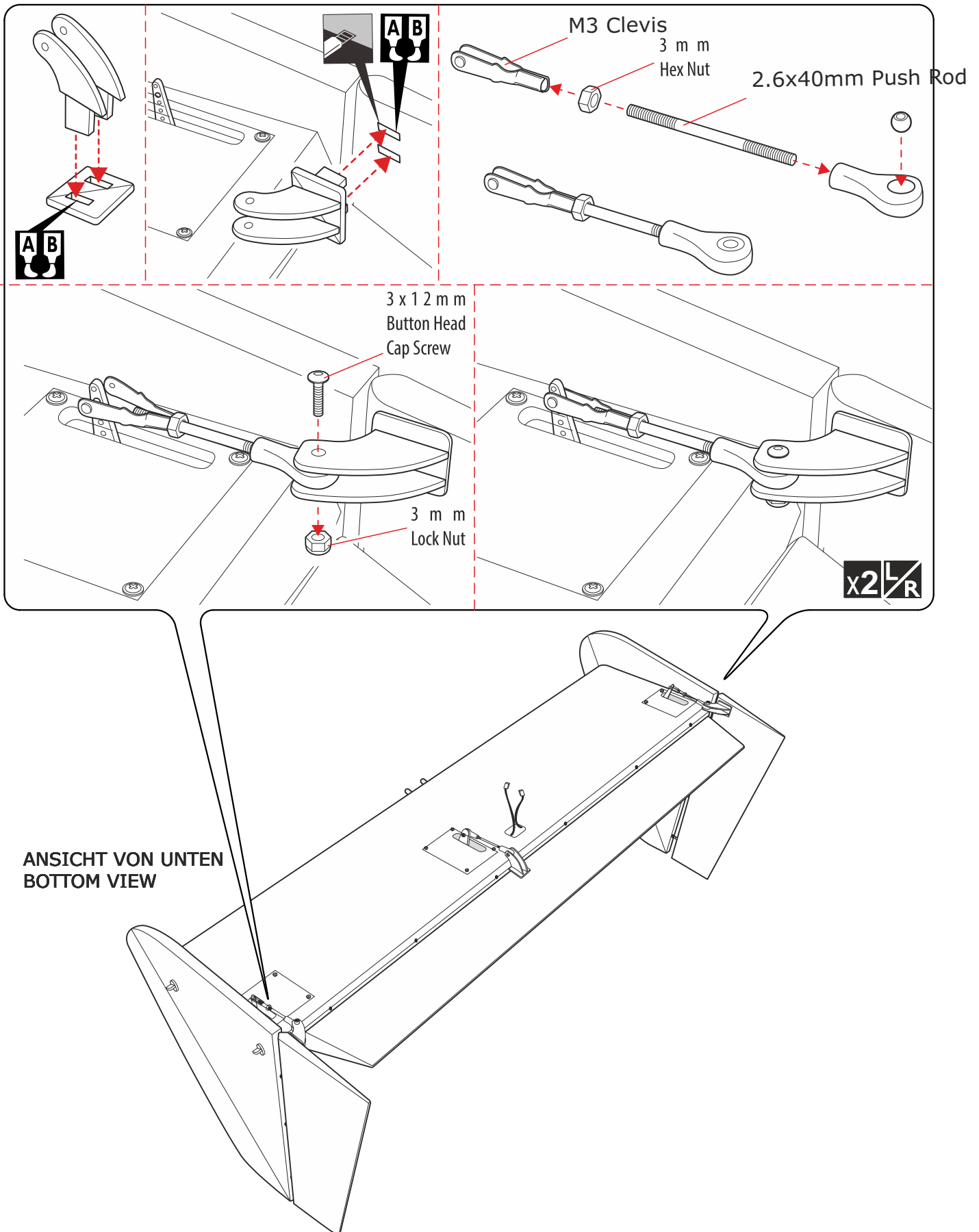

??*/ HORIZONTAL & VERTICAL STABILIZER STRUTS

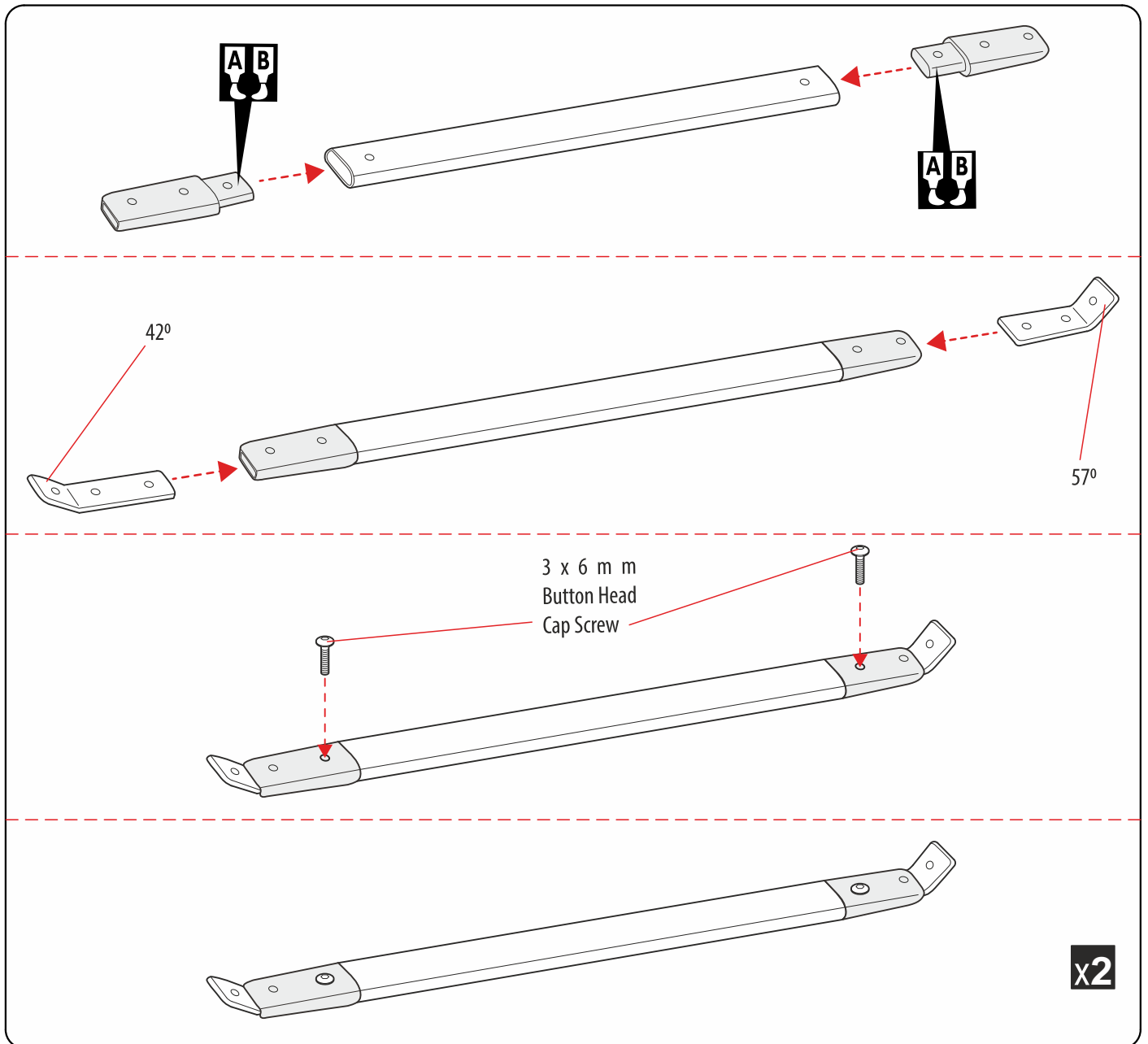
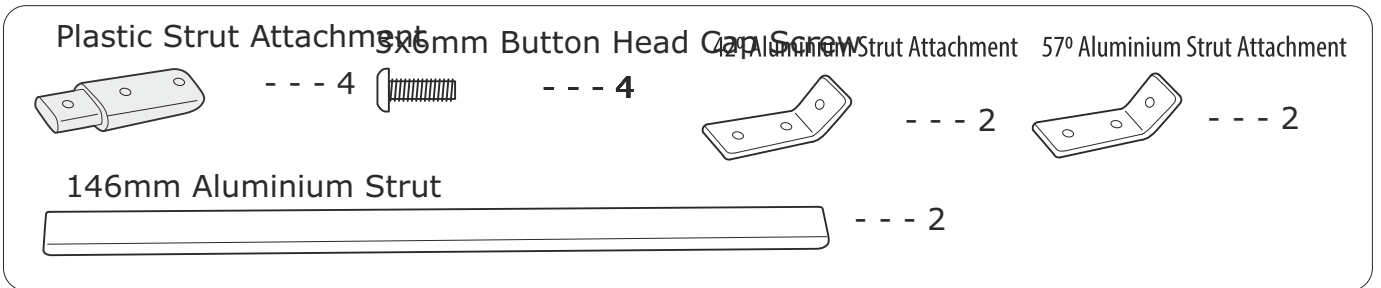

4. MONTAGE / ASSEMBLY

3x25mm Socket Head Cap Screw

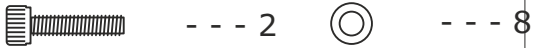

3x40mm Socket Head Cap Screw

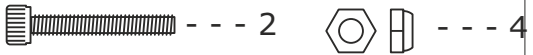

6x45mm Plastic Screw

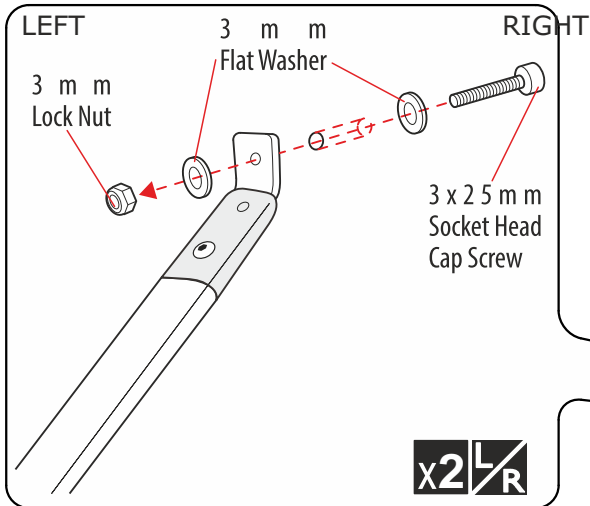

**DRAUFSICHT
TOP VIEW**

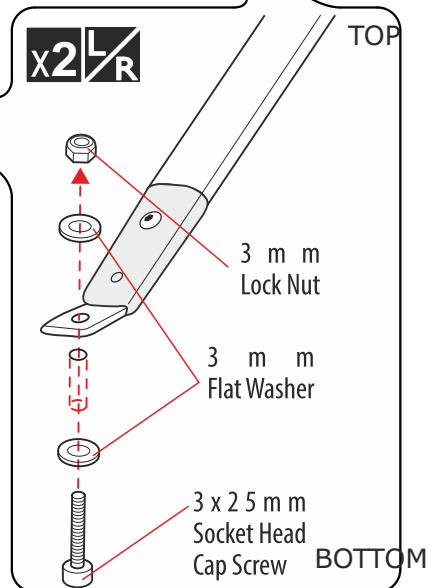
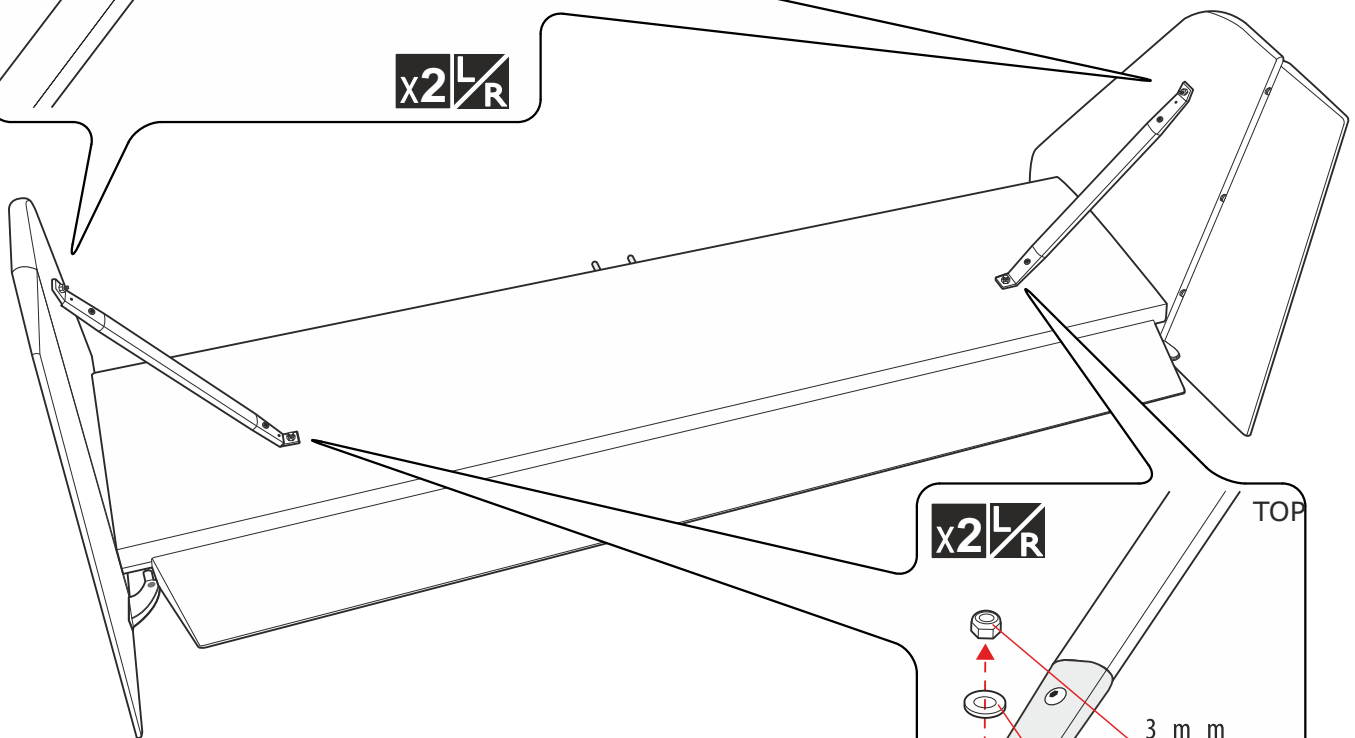

Horizontal & Vertical Stabilizer Side View

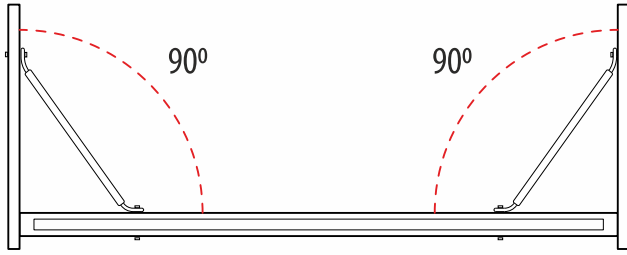

DRAUFSICHT
TOP VIEW

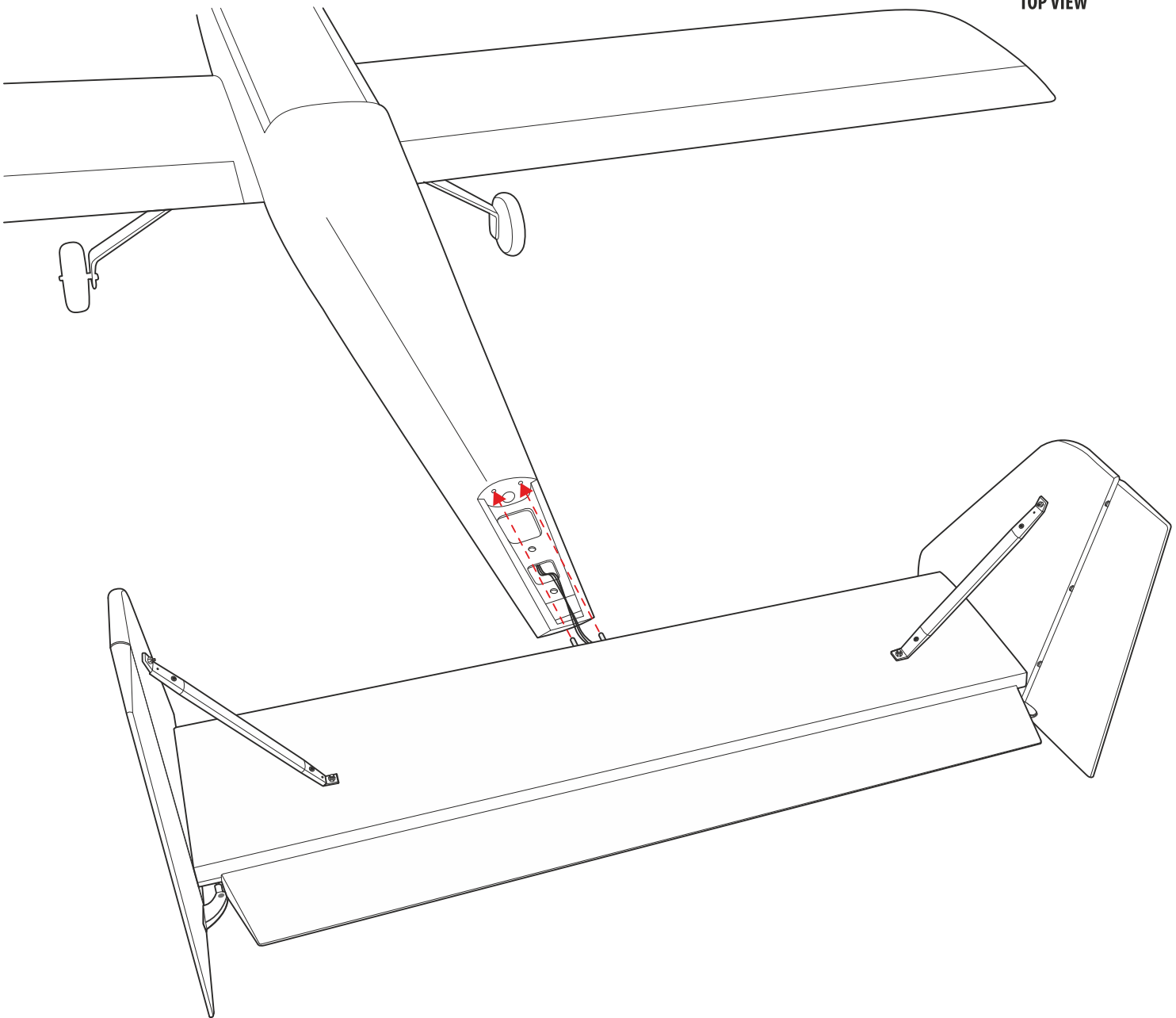

4. MONTAGE / ASSEMBLY

DRAUSICHT
TOP VIEW

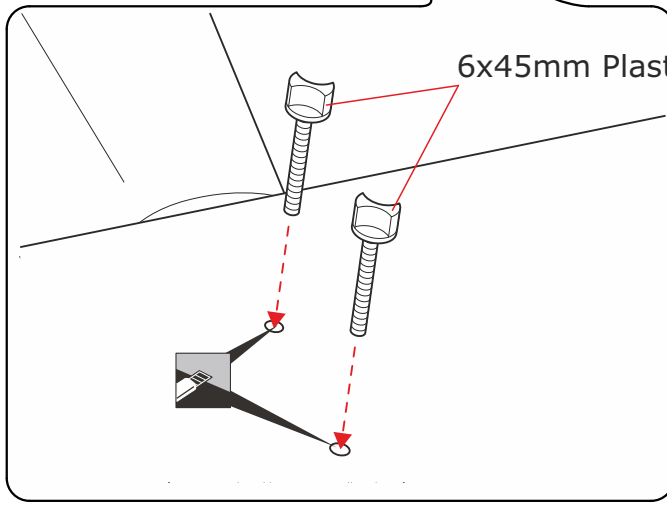
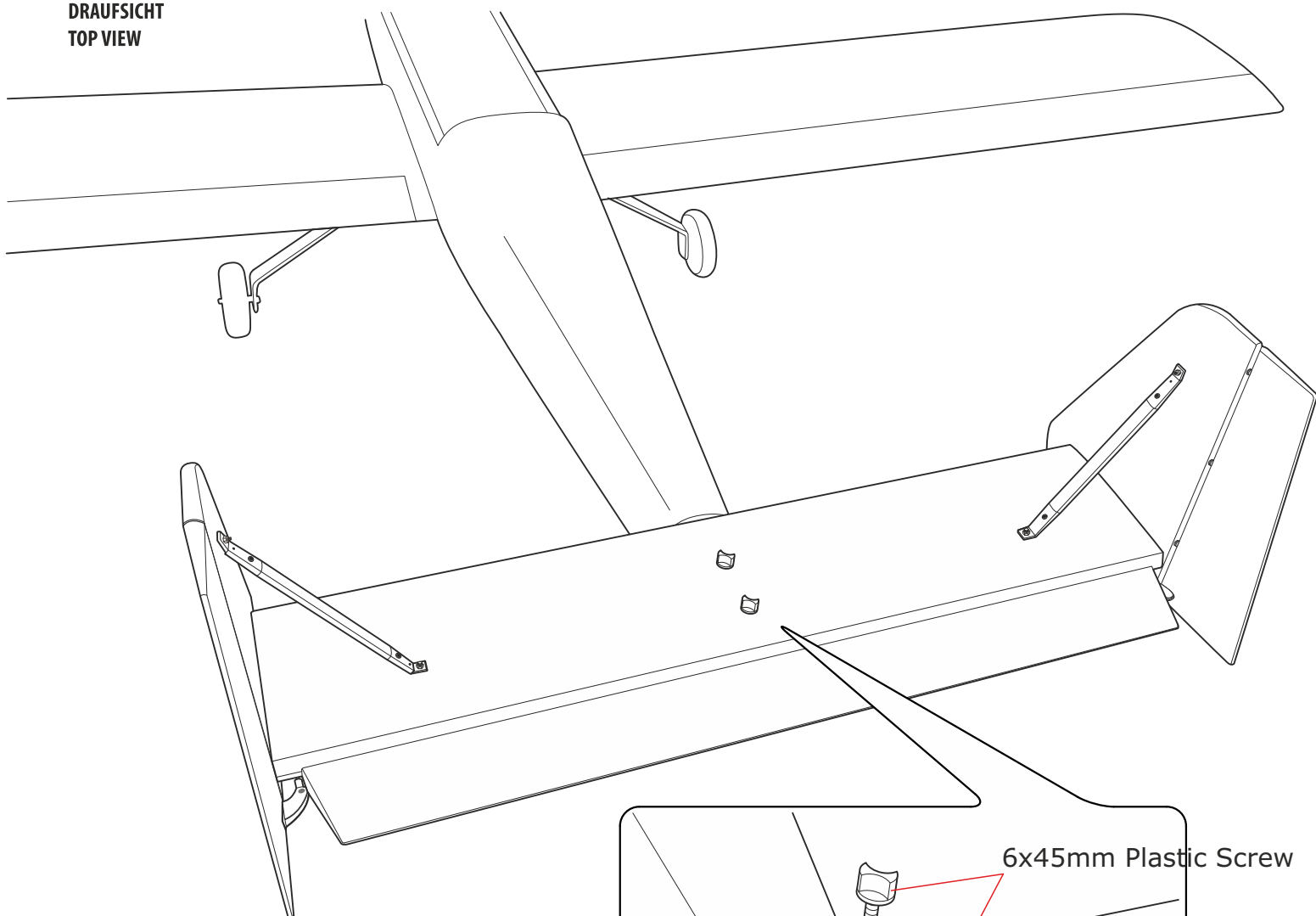

6x45mm Plastic Screw

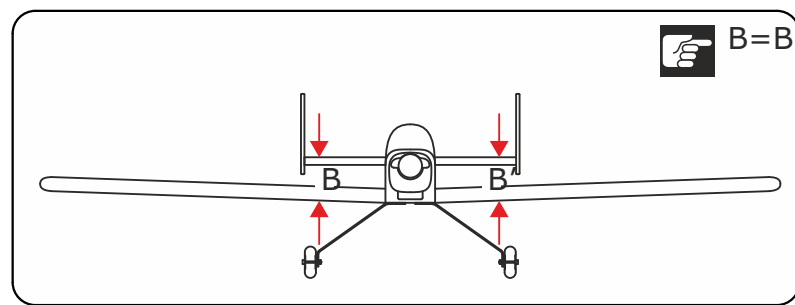
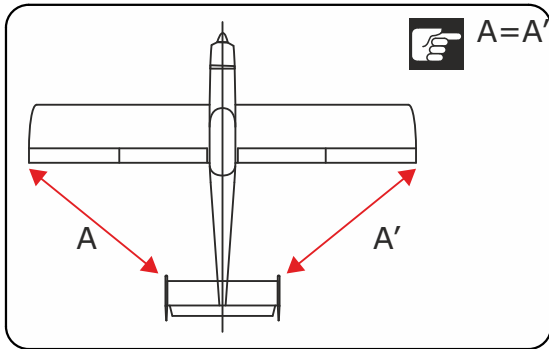

Motorträger /Engine Mount

Using plate of plywood (supplied with the kit) mark the holes onto the fire wall for INSTALLING THE the engine mount for DLE-55CC or motor 180.
May be you also need to trim some wood from the tri-angle wood for the installation.

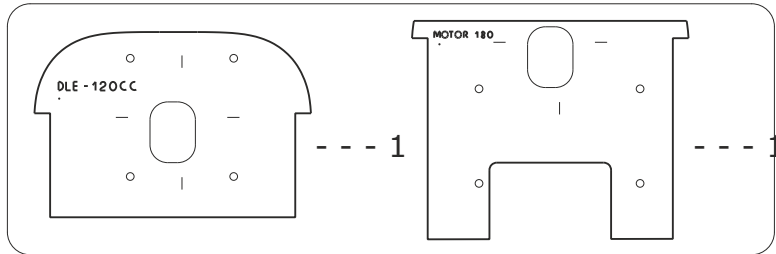

DLE-120CC

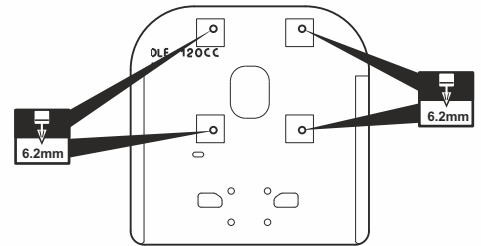
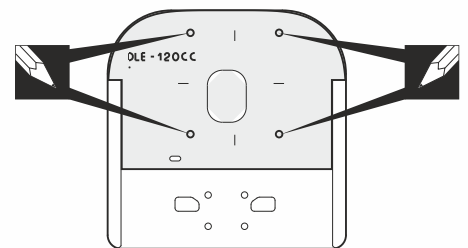
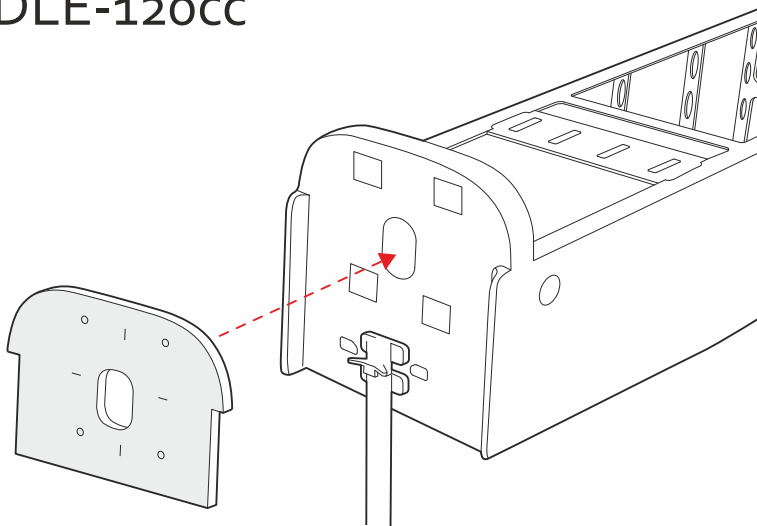

Motor 180

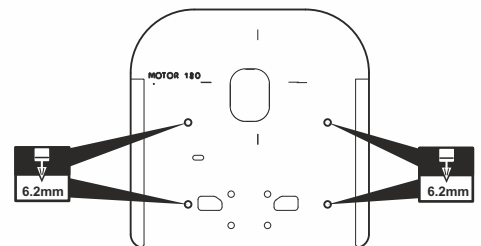
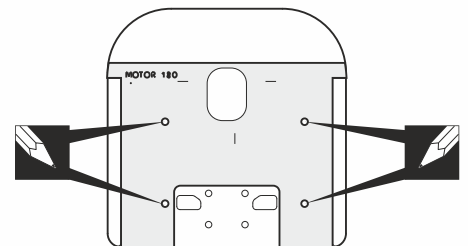
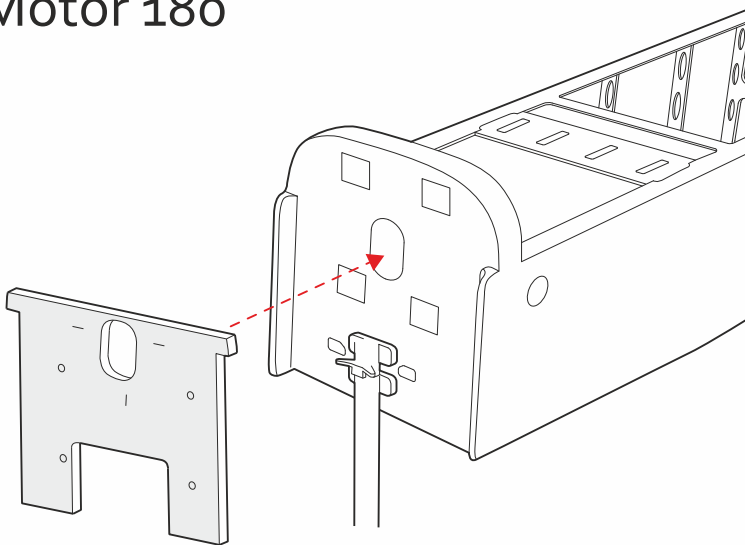

4. MONTAGE / ASSEMBLY

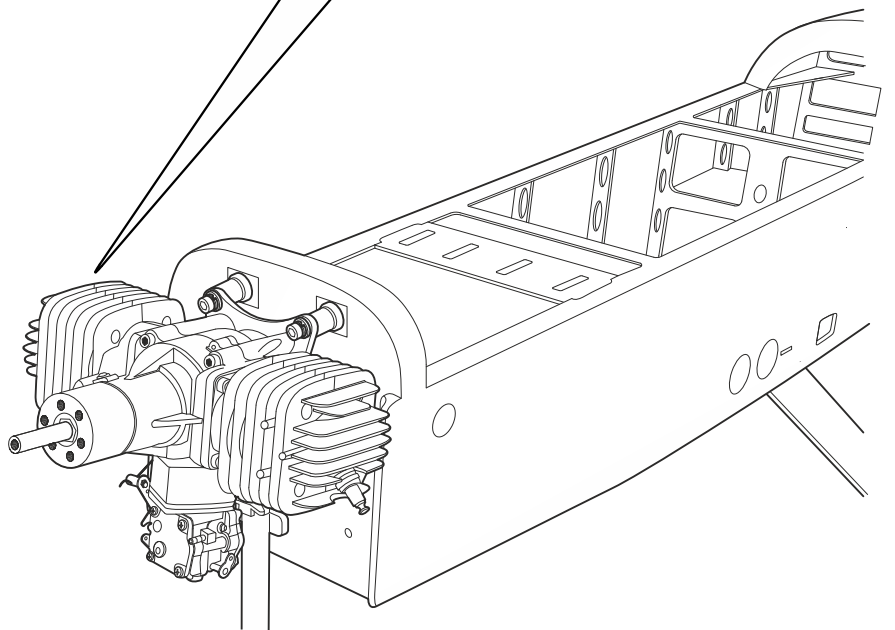
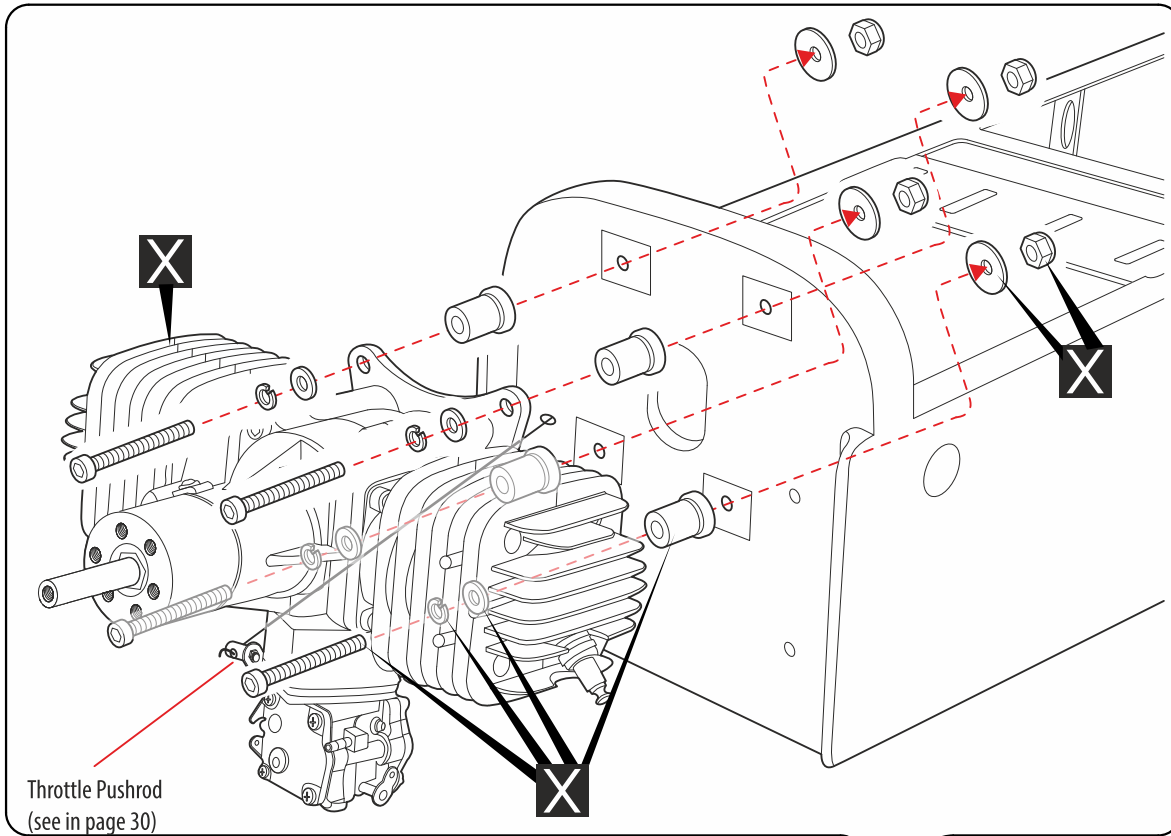

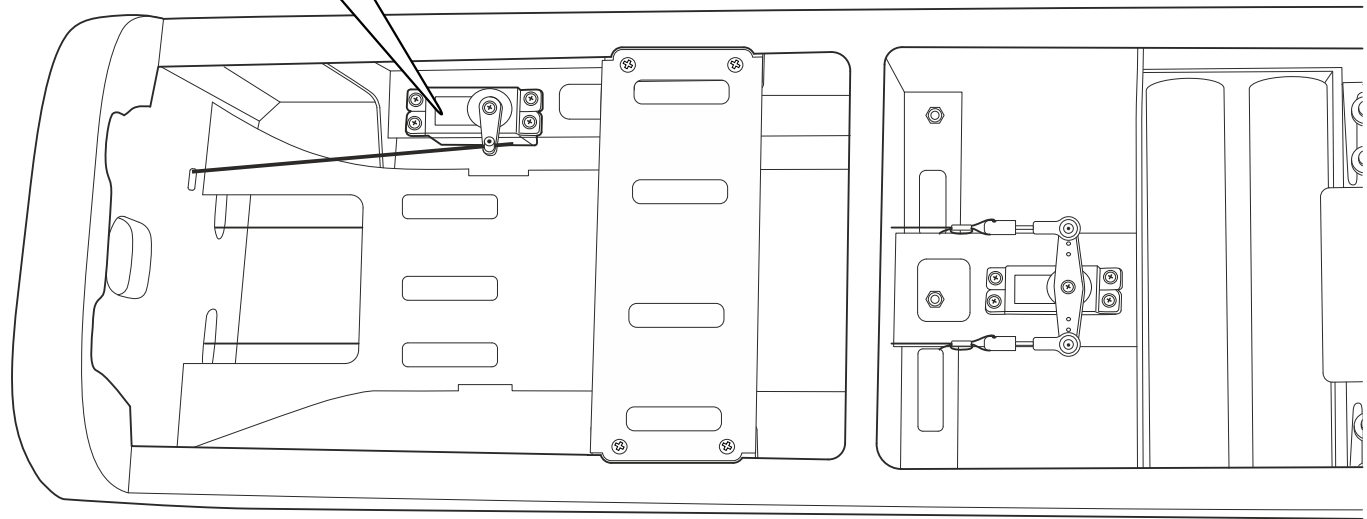
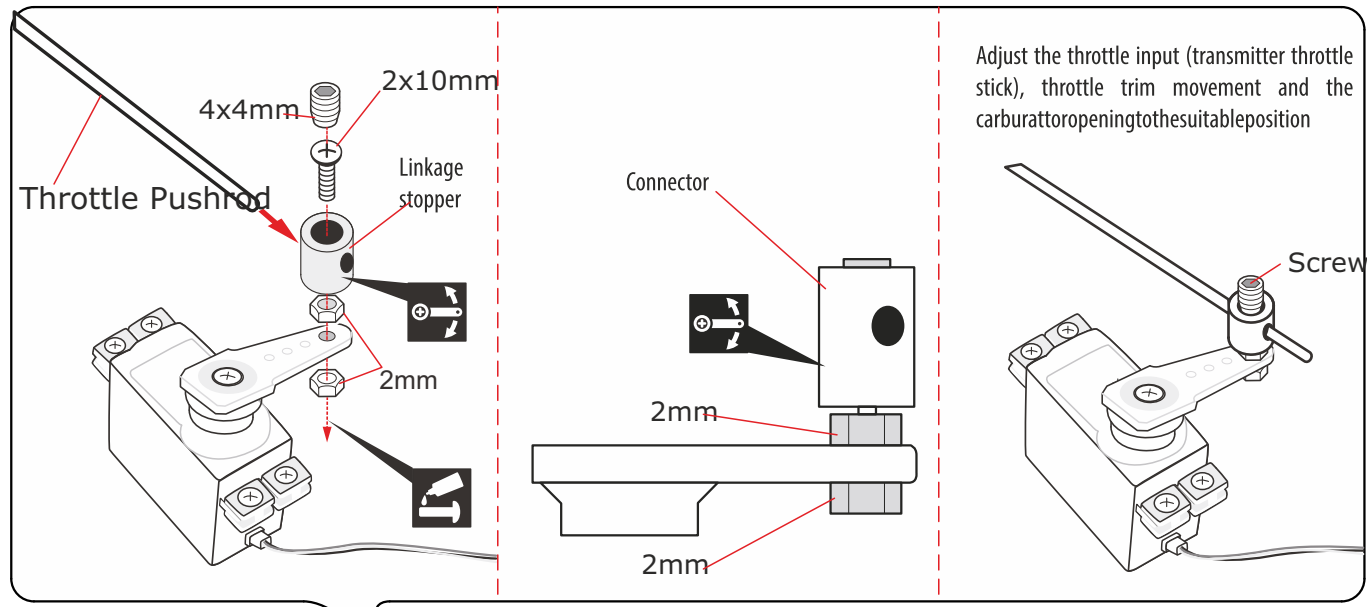
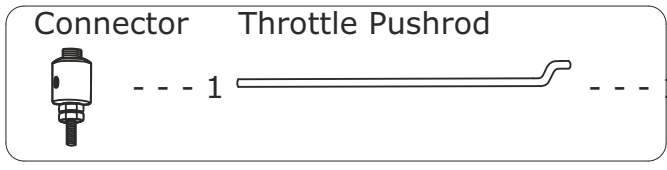

??/?/ INSTALLING THE FUEL TANK

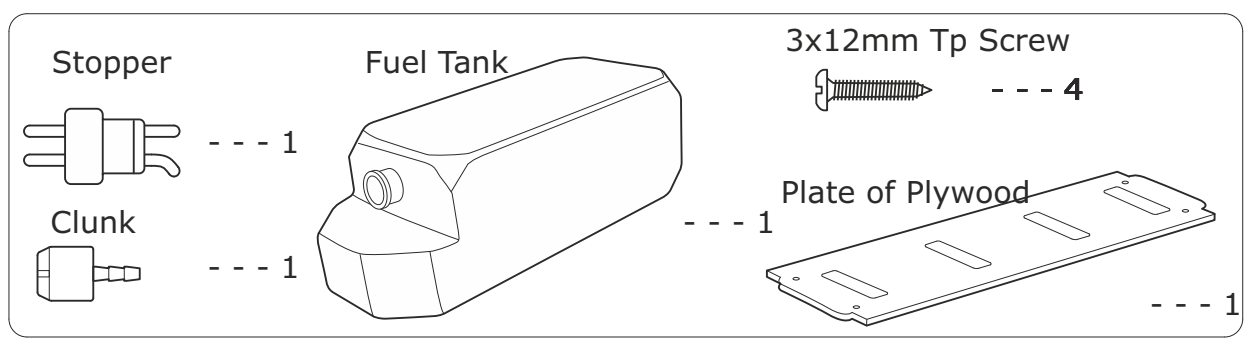

4. MONTAGE / ASSEMBLY

INSTALLING THE STOPPER

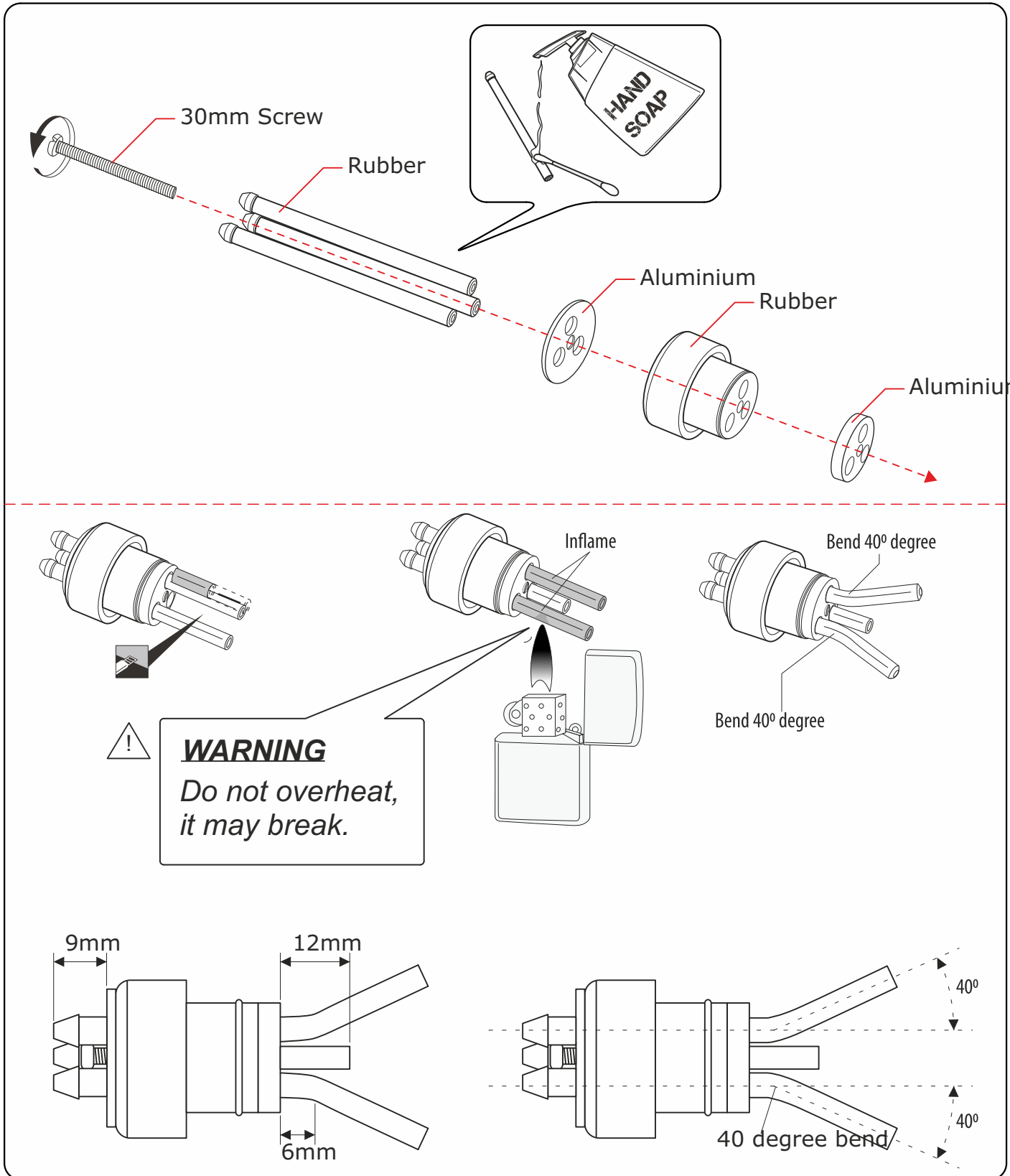

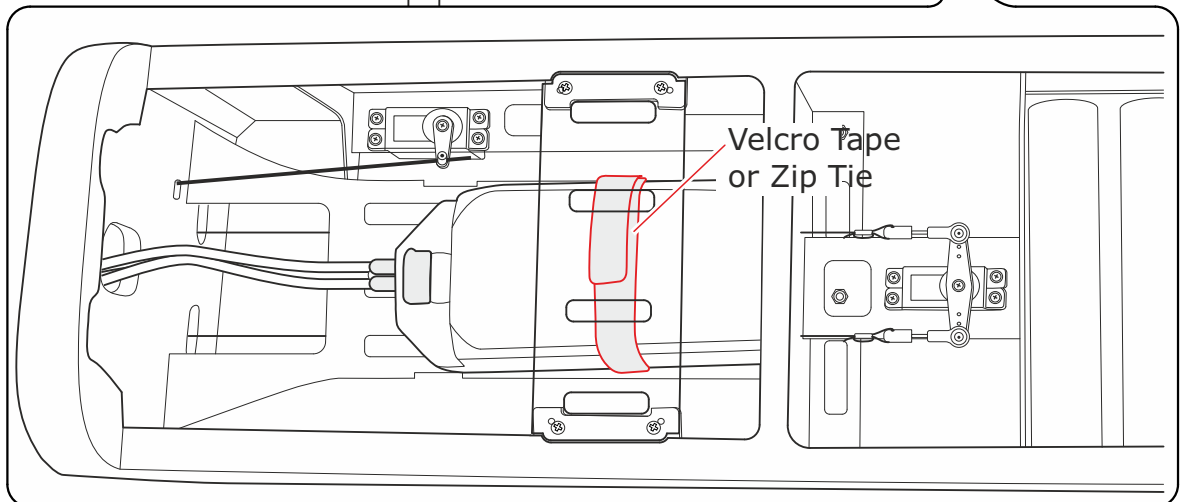
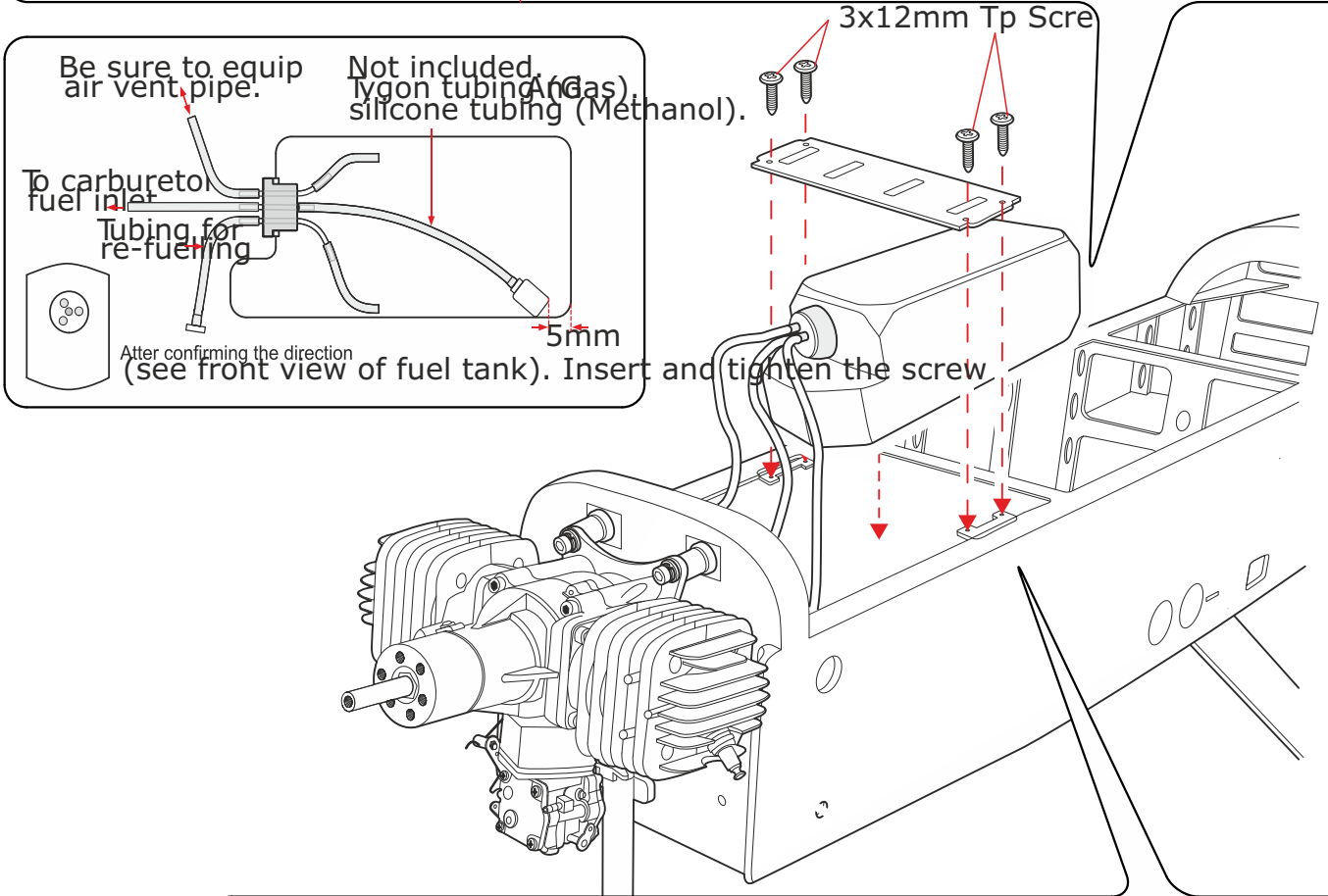
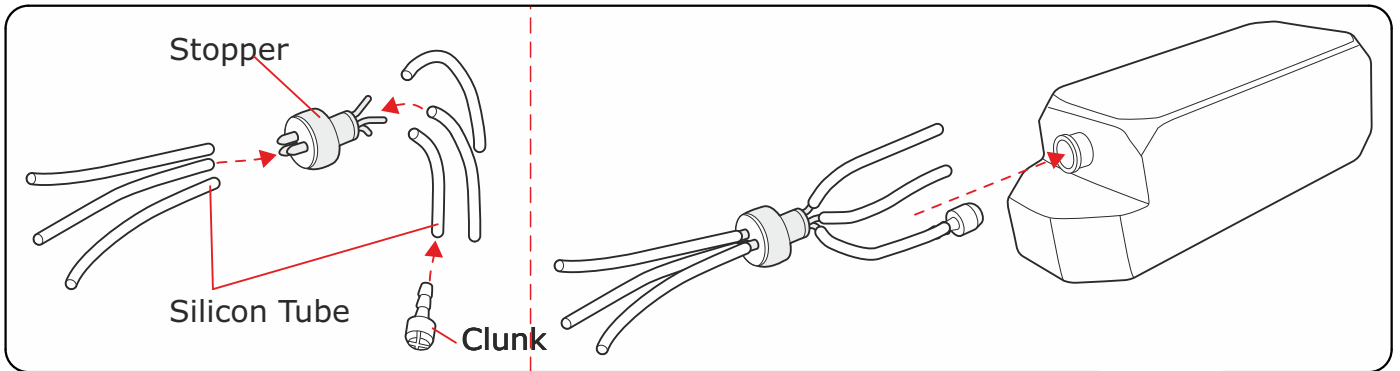

4. MONTAGE / ASSEMBLY

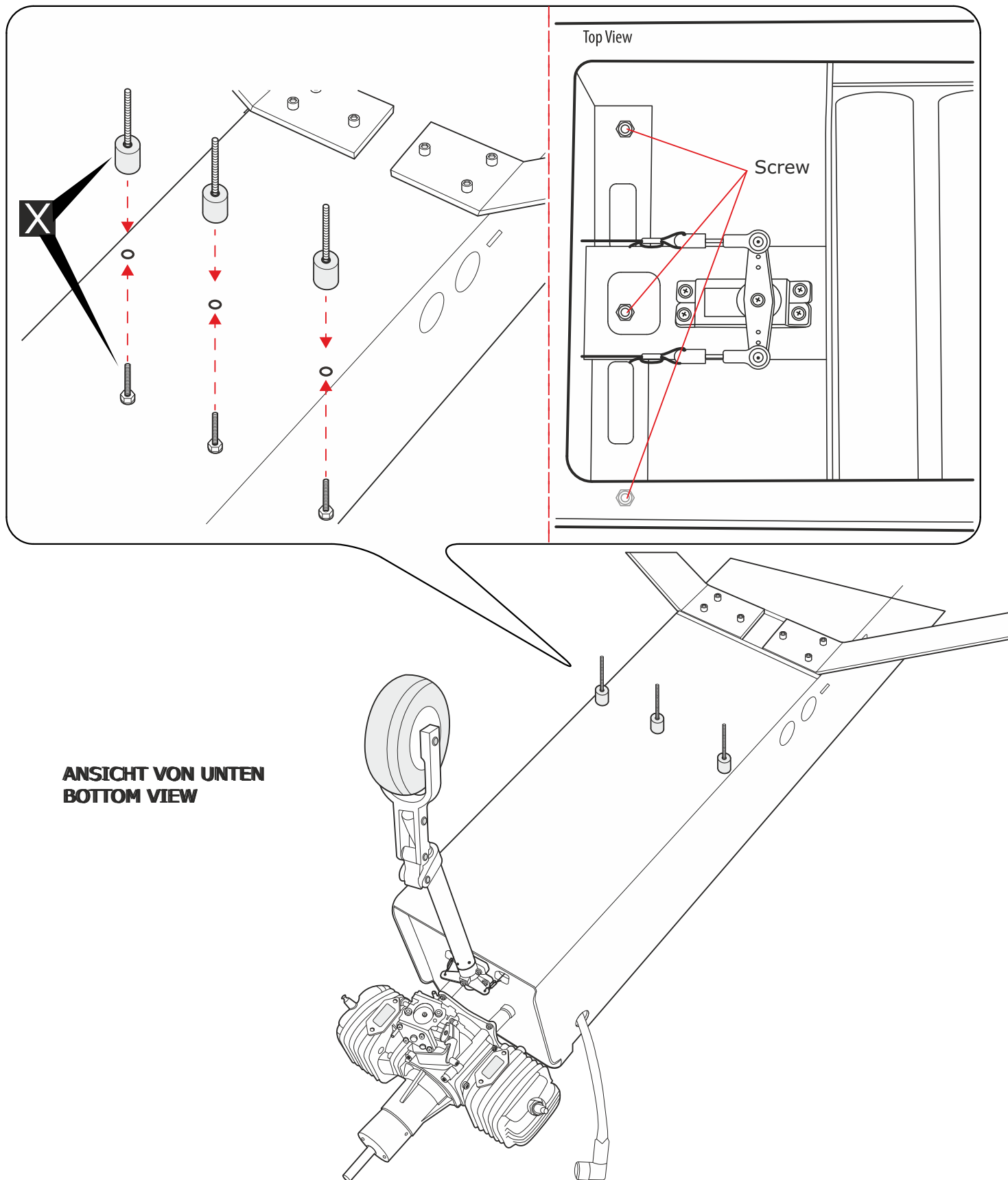

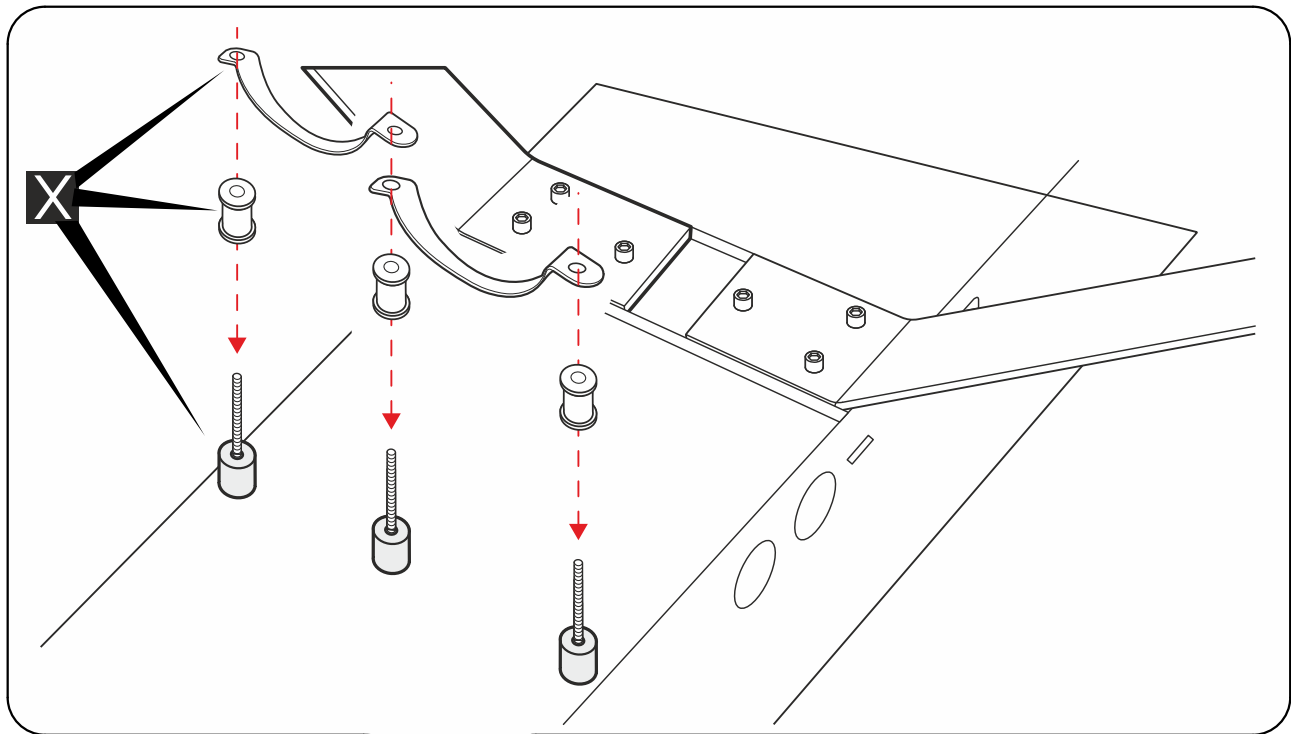

ANSICHT VON UNTEN
BOTTOM VIEW

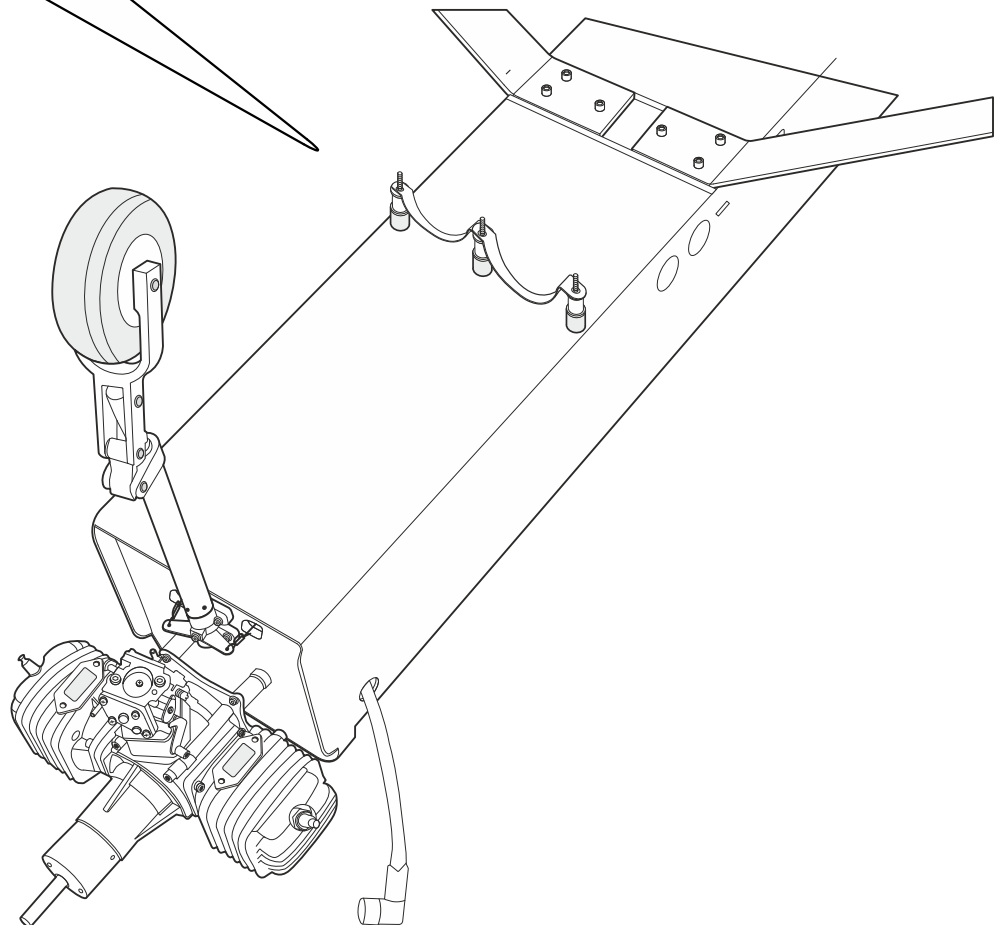

ANSICHT VON UNTEN
BOTTOM VIEW

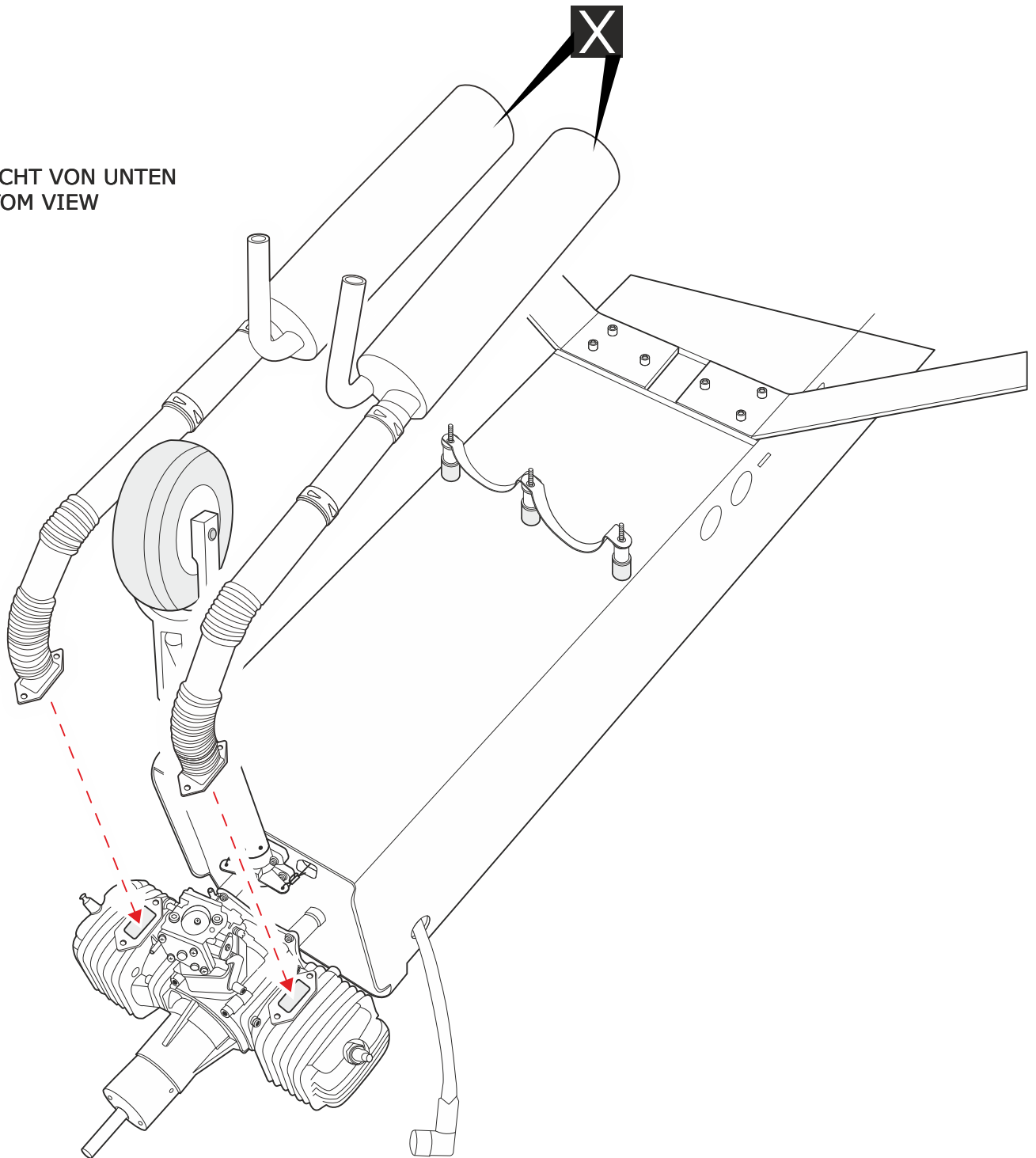



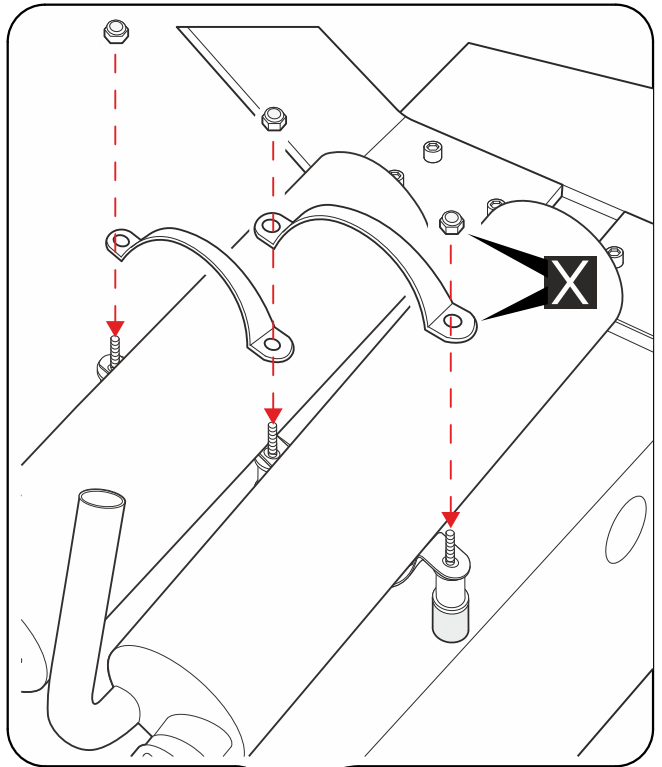
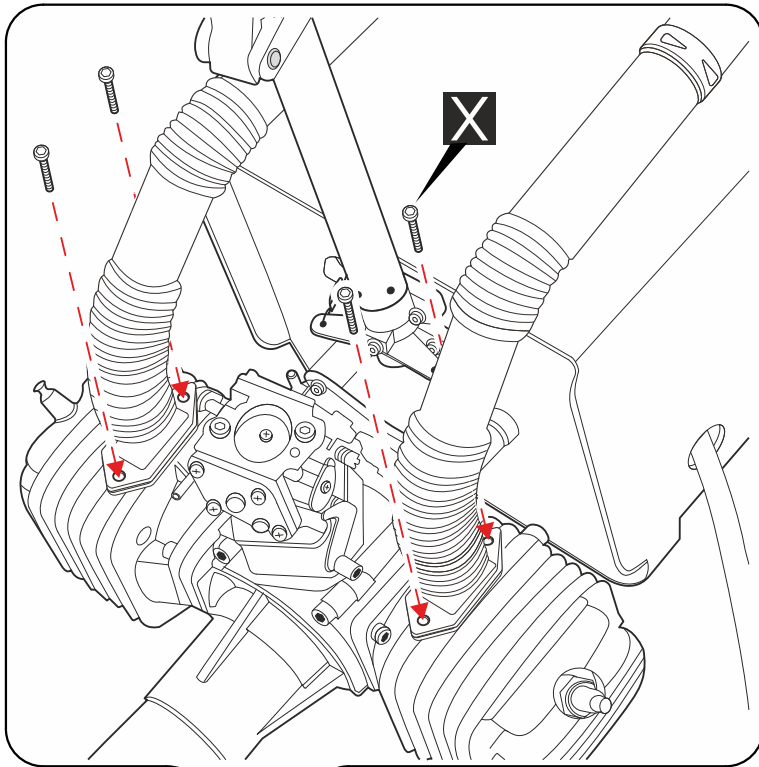

4. MONTAGE / ASSEMBLY

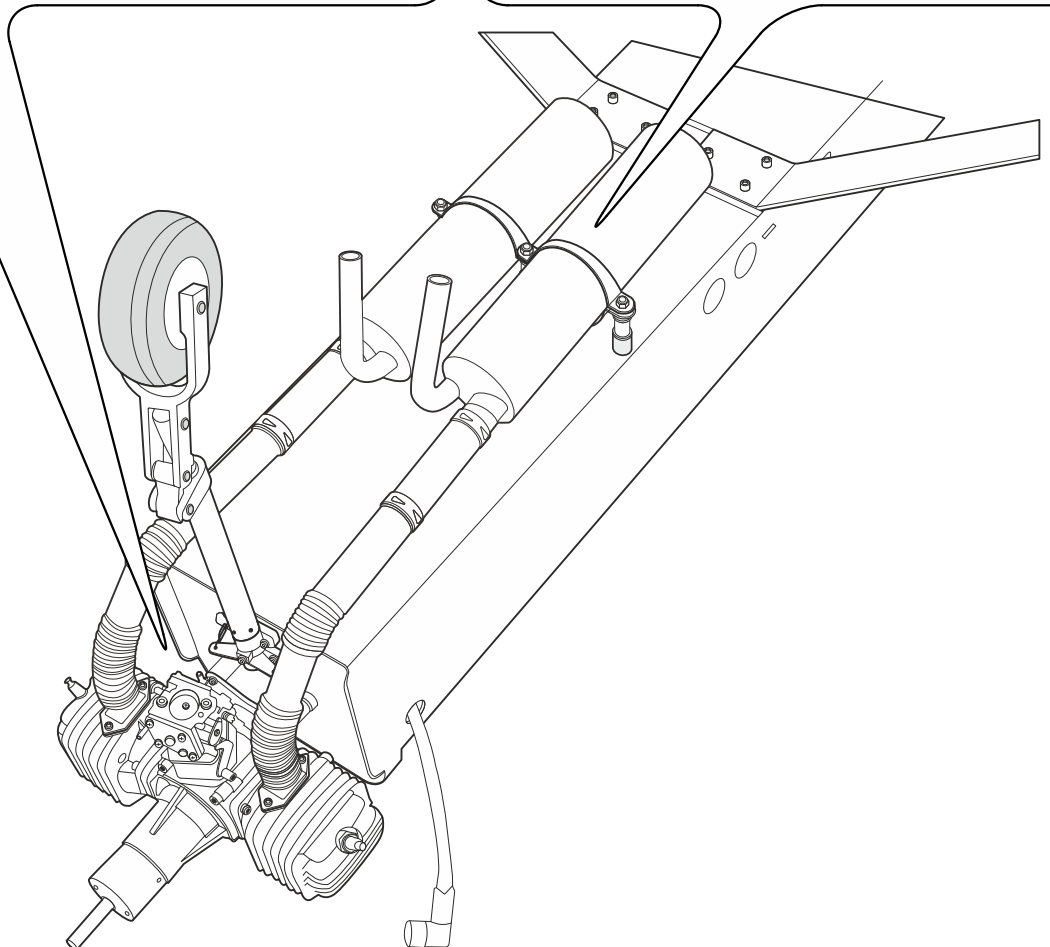

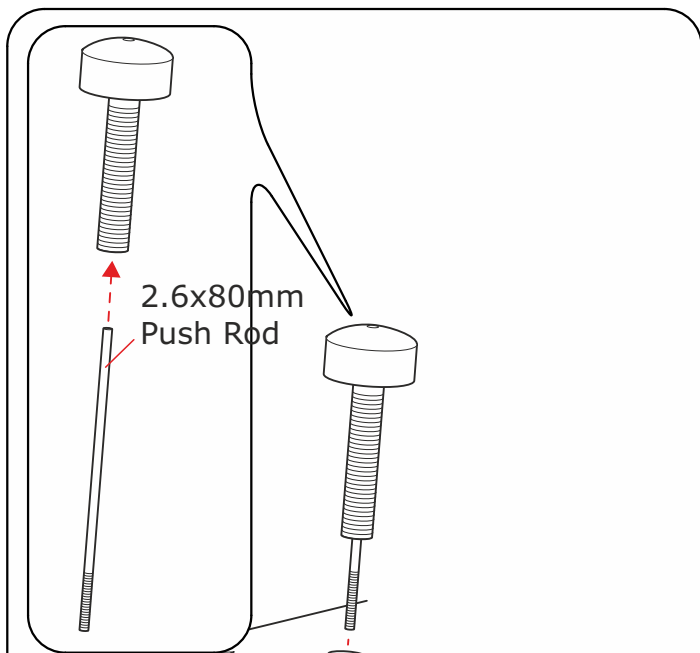
ANSICHT VON UNTEN
BOTTOM VIEW

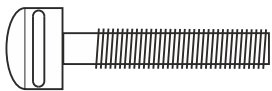
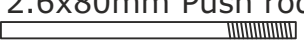

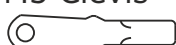

- Tow Screw  --- 4
- 2.6x80mm Push rod  --- 2
- 8mm Hex Nut  --- 1
- M3 Clevis  --- 1
- 3mm Hex Nut  --- 1

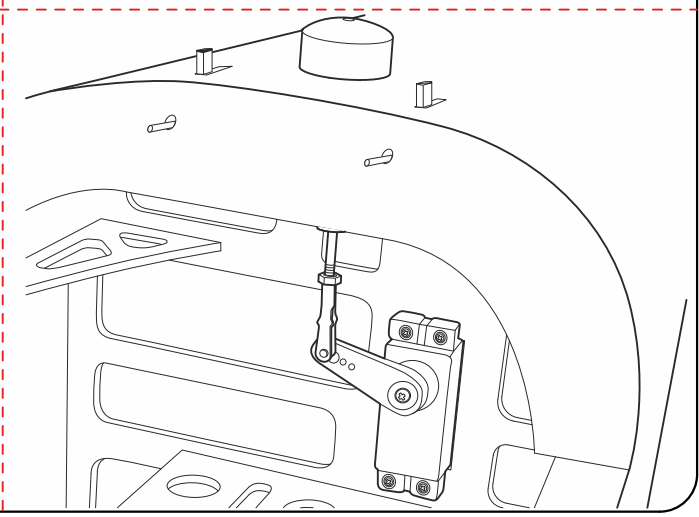
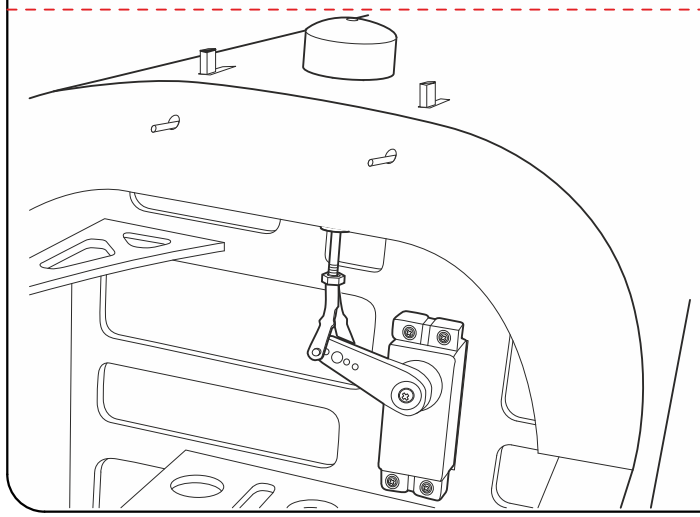
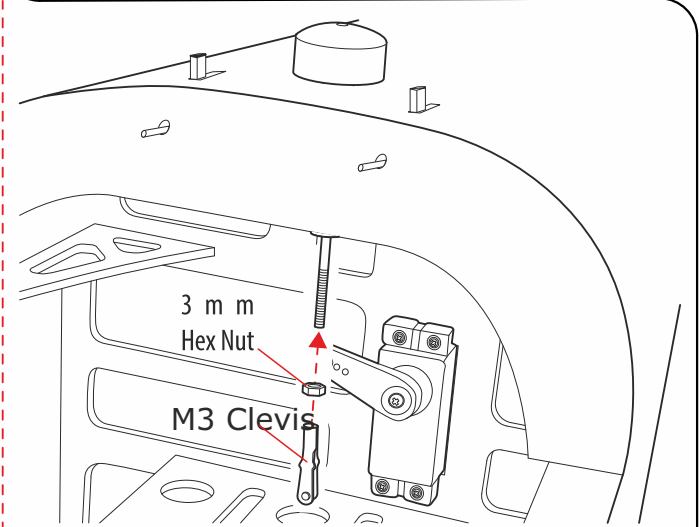
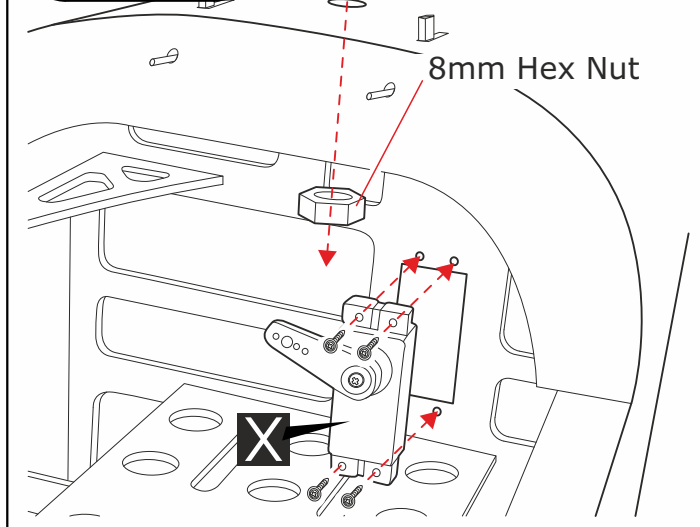

4. MONTAGE / ASSEMBLY

Ø32 -785mm Aluminium Tube



--- 1

Ø32 -985mm Aluminium Tube



--- 1

**DRAUFSICHT
TOP VIEW**

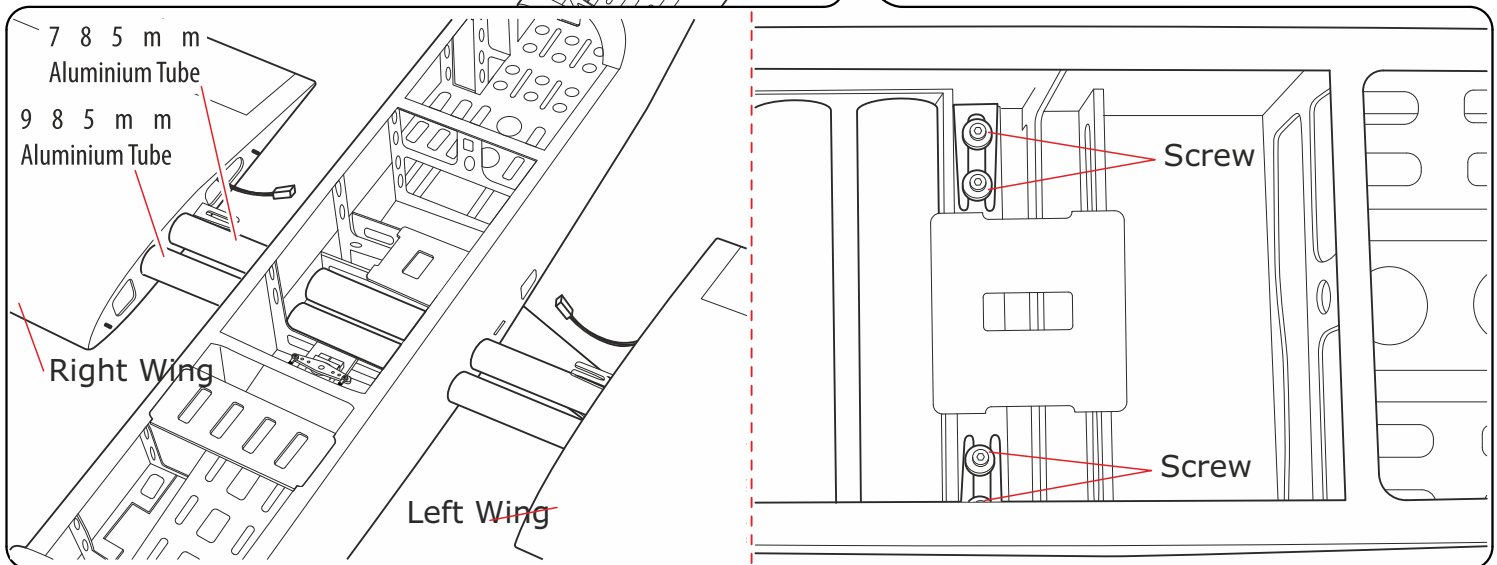
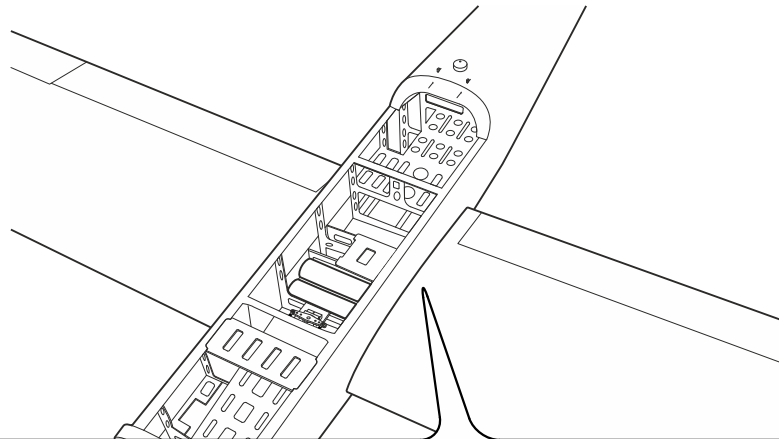

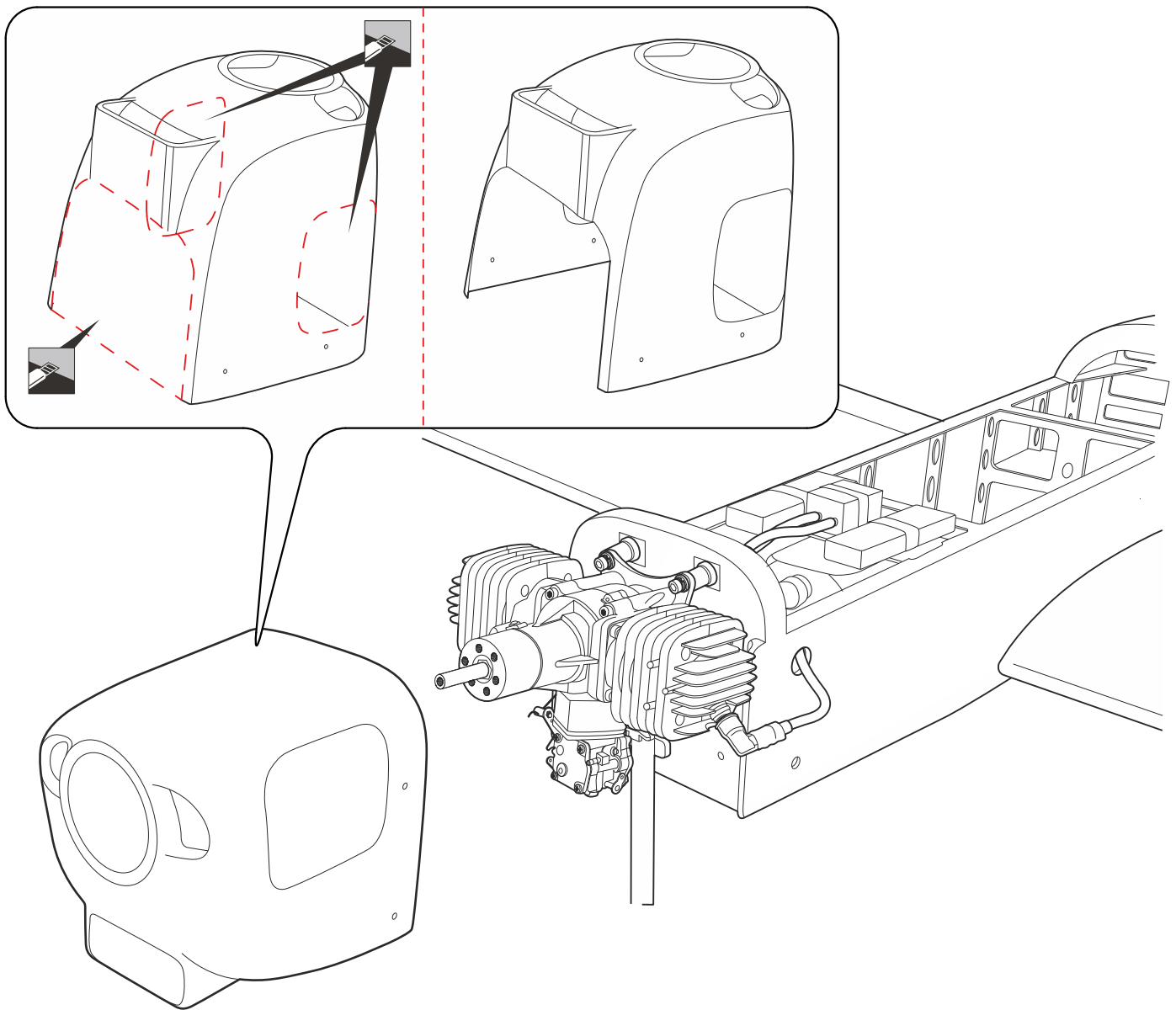
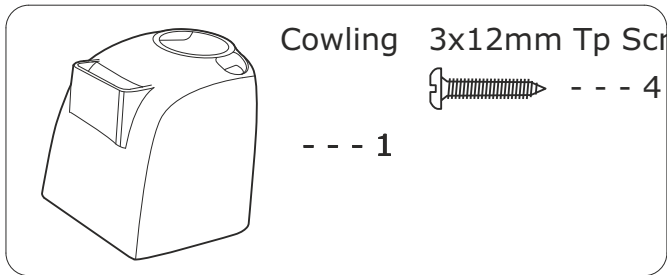

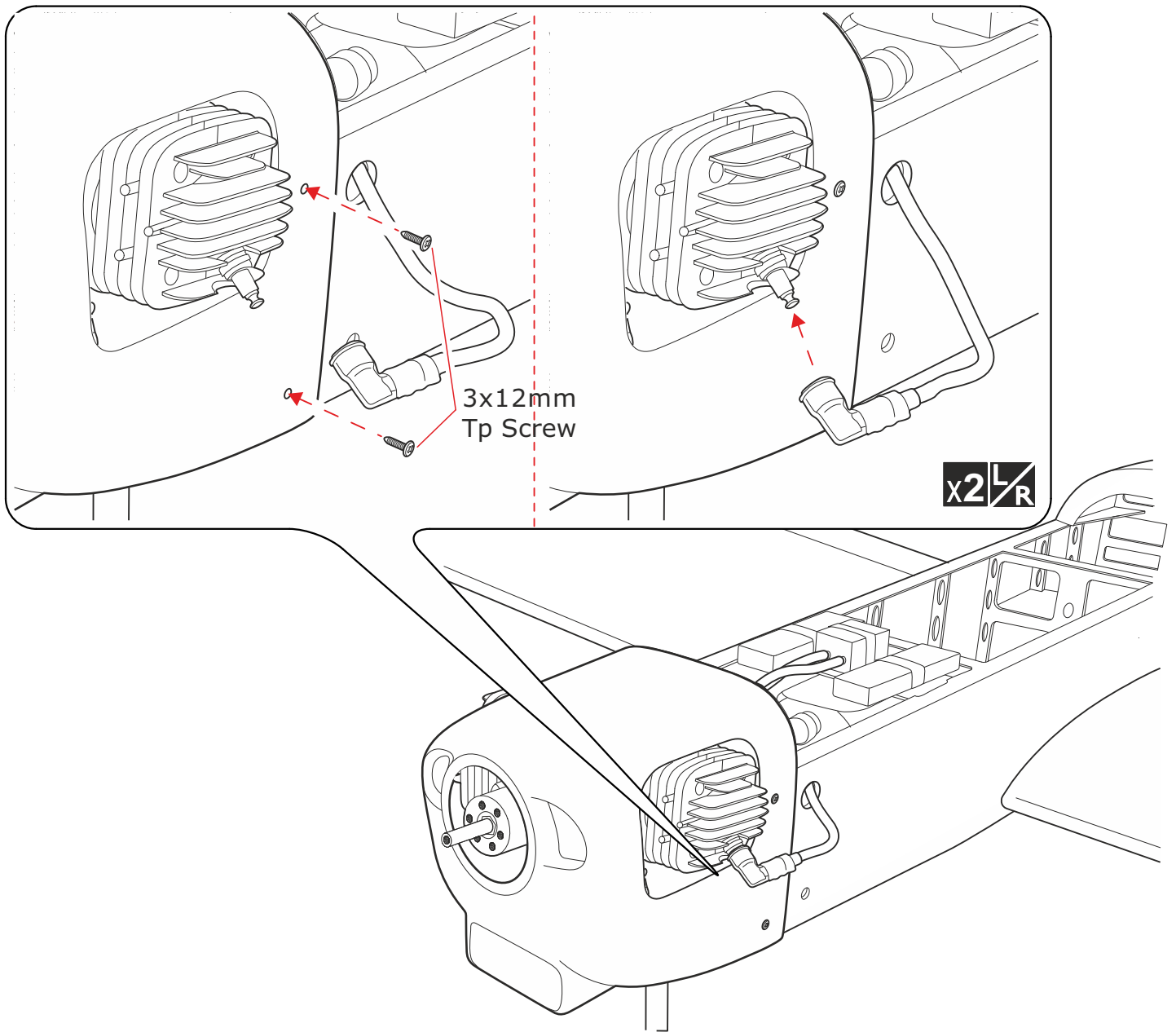

**DRAUFSICHT
TOP VIEW**

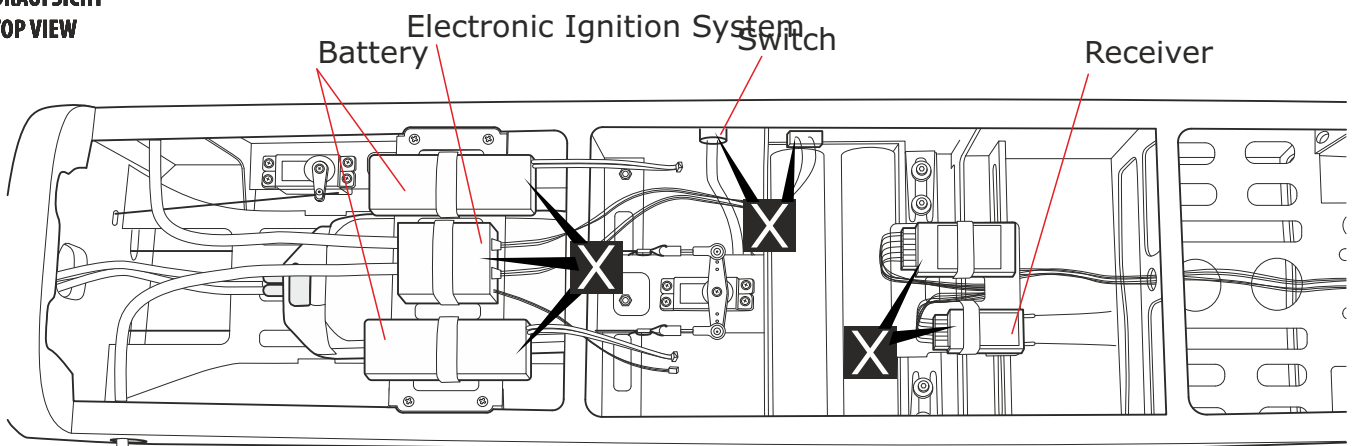

4. MONTAGE / ASSEMBLY

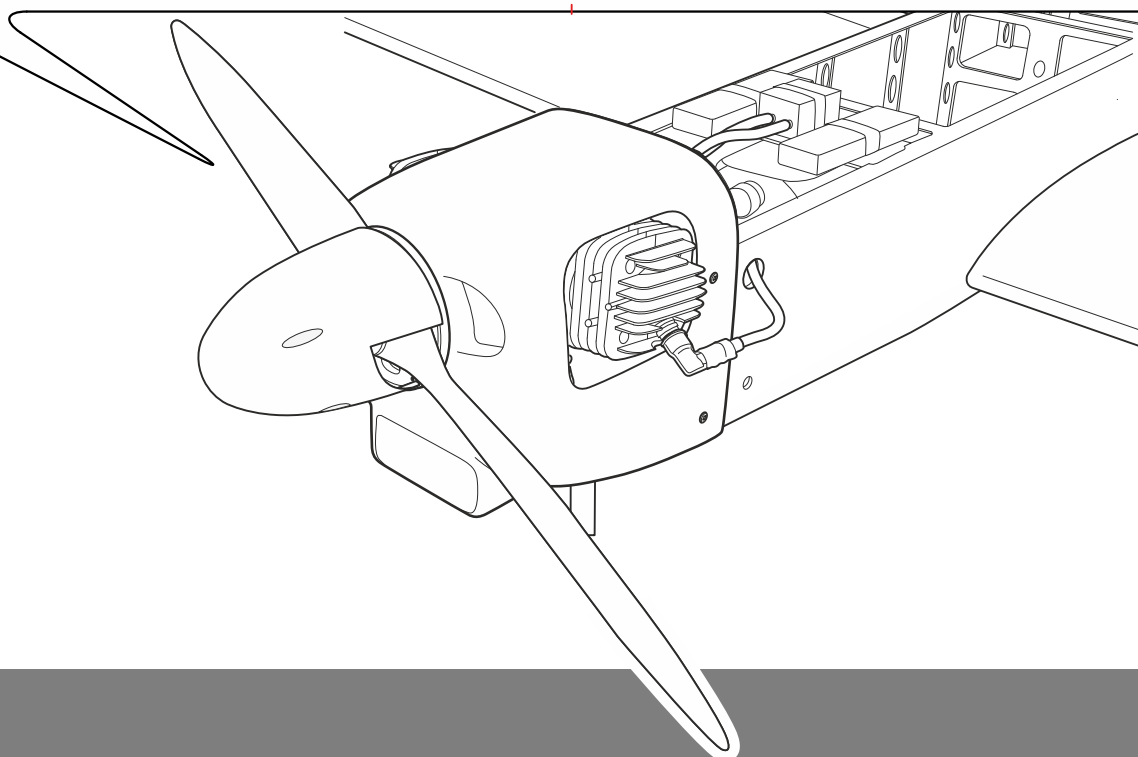
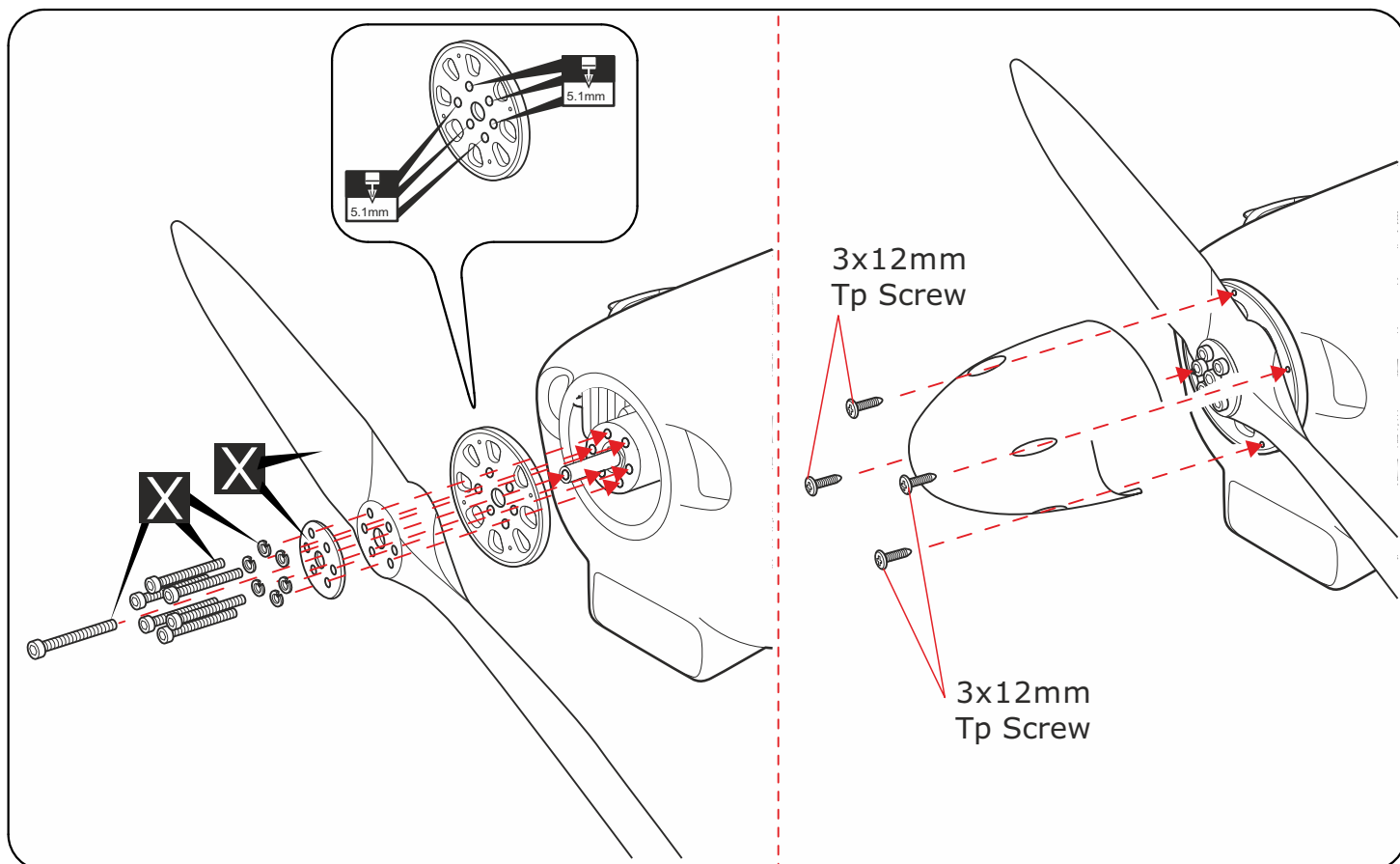
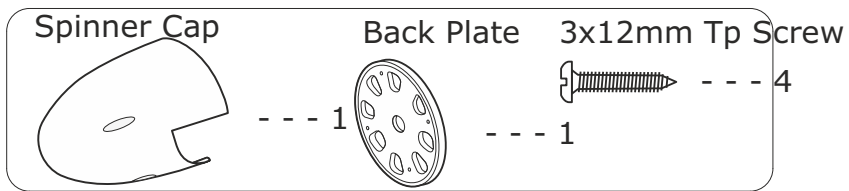

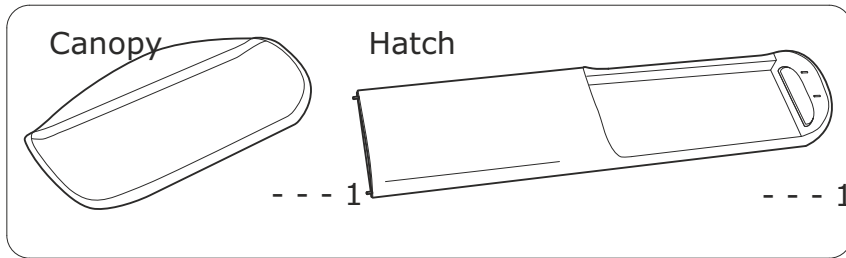

**Verwenden Sie den Klebstoff
Best.Nr. X3583 aus dem Pichler Sortiment
zum Ankleben der Kabinenhaube auf den
Kabinenhaubenrahmen**

**Use our glue No. X3583 to glue the
canopy to the canopy frame.**

Position the canopy so the rear frame on the canopy is aligned with the rear edge of the cockpit opening. Use canopy glue to secure the canopy to the canopy hatch. Use low-tack tape to hold the canopy in position until the glue fully cures. Wrap the tape completely around the canopy hatch.

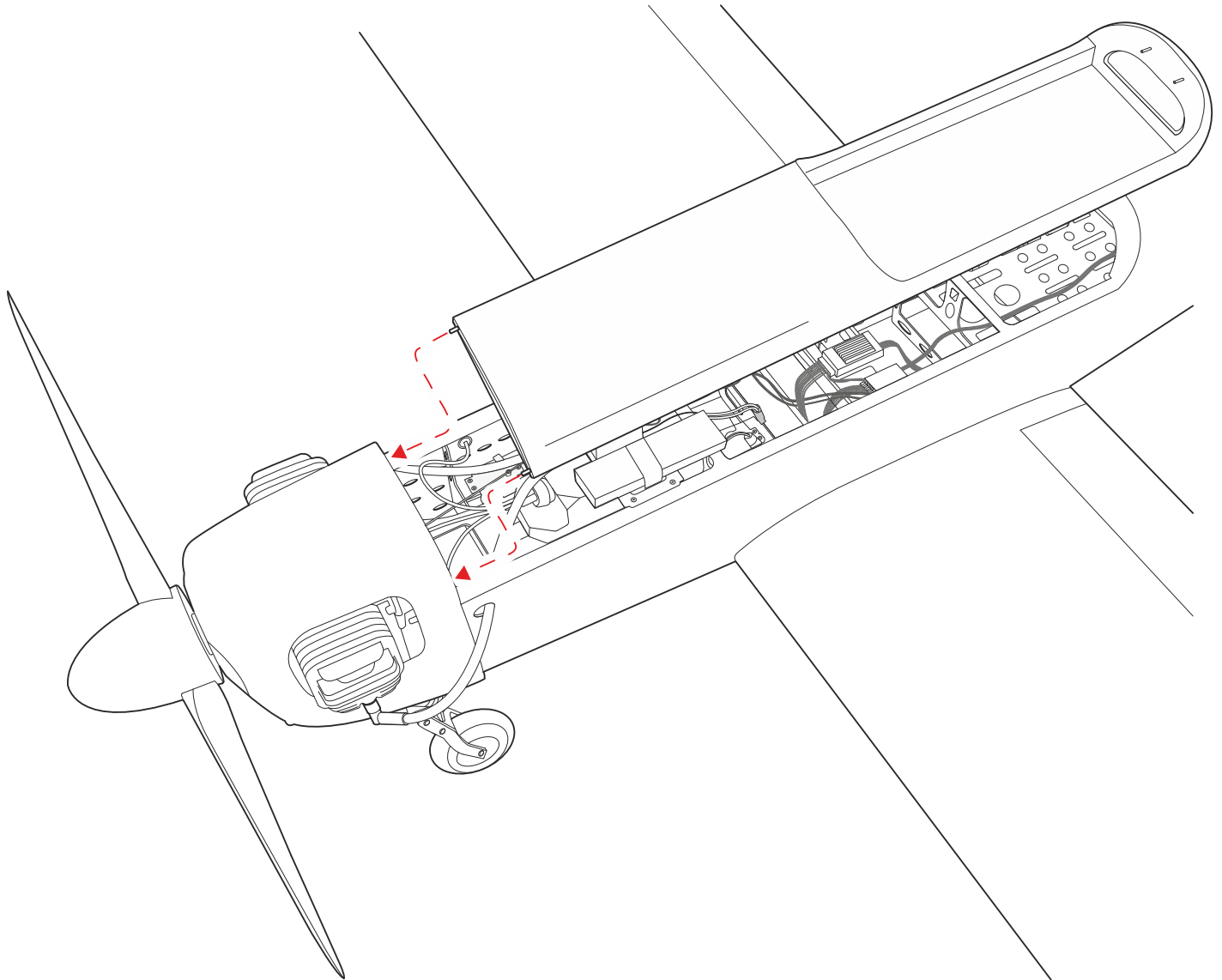

4. MONTAGE / ASSEMBLY

DRAUFSICHT
TOP VIEW

**Verwenden Sie den Klebstoff
Best.Nr. X3583 aus dem Pichler Sortiment
zum Ankleben der Kabinenhaube auf den
Kabinenhaubenrahmen**

Use our glue No. X3583 to glue the
canopy to the canopy frame.

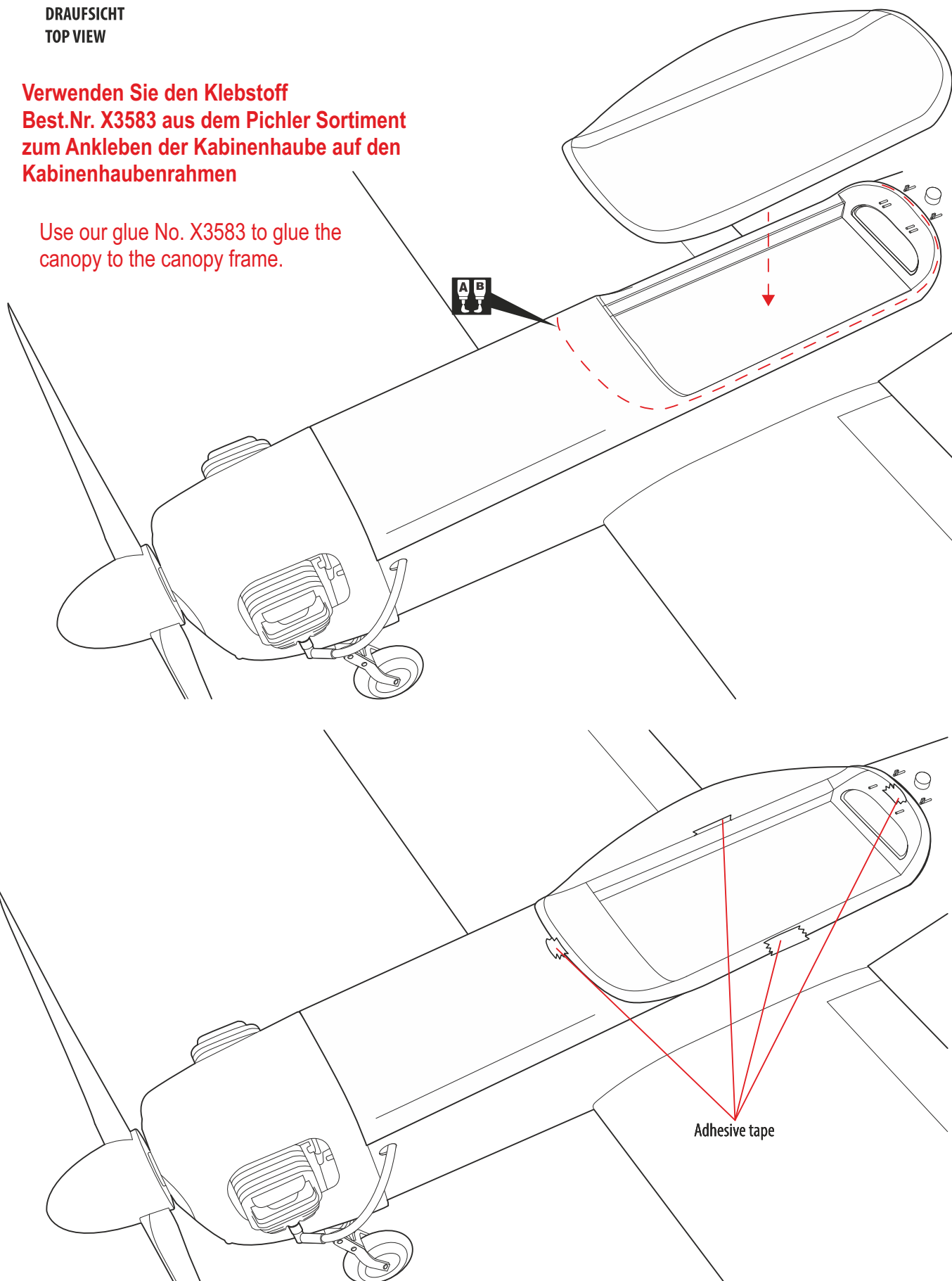

BOOST Elektromotor mit Getriebe / BOOST electric motor with gear box

5x60mm Socket Head Cap Screw 5mm Flat Washer 5mm Flat Washer



5mm Spring Washer 12x30mm Aluminium Tube 5mm Lock Nut

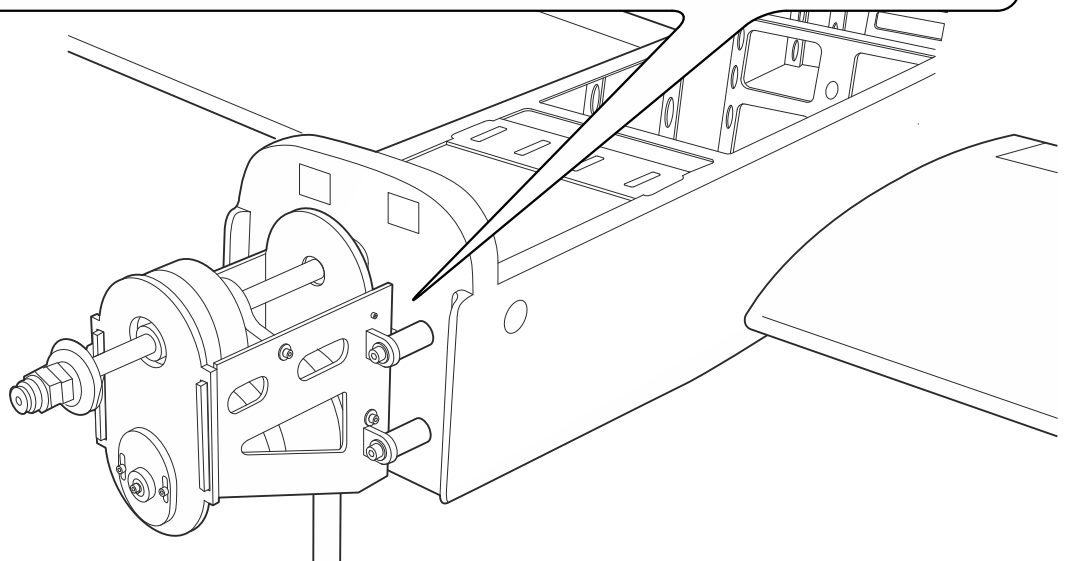
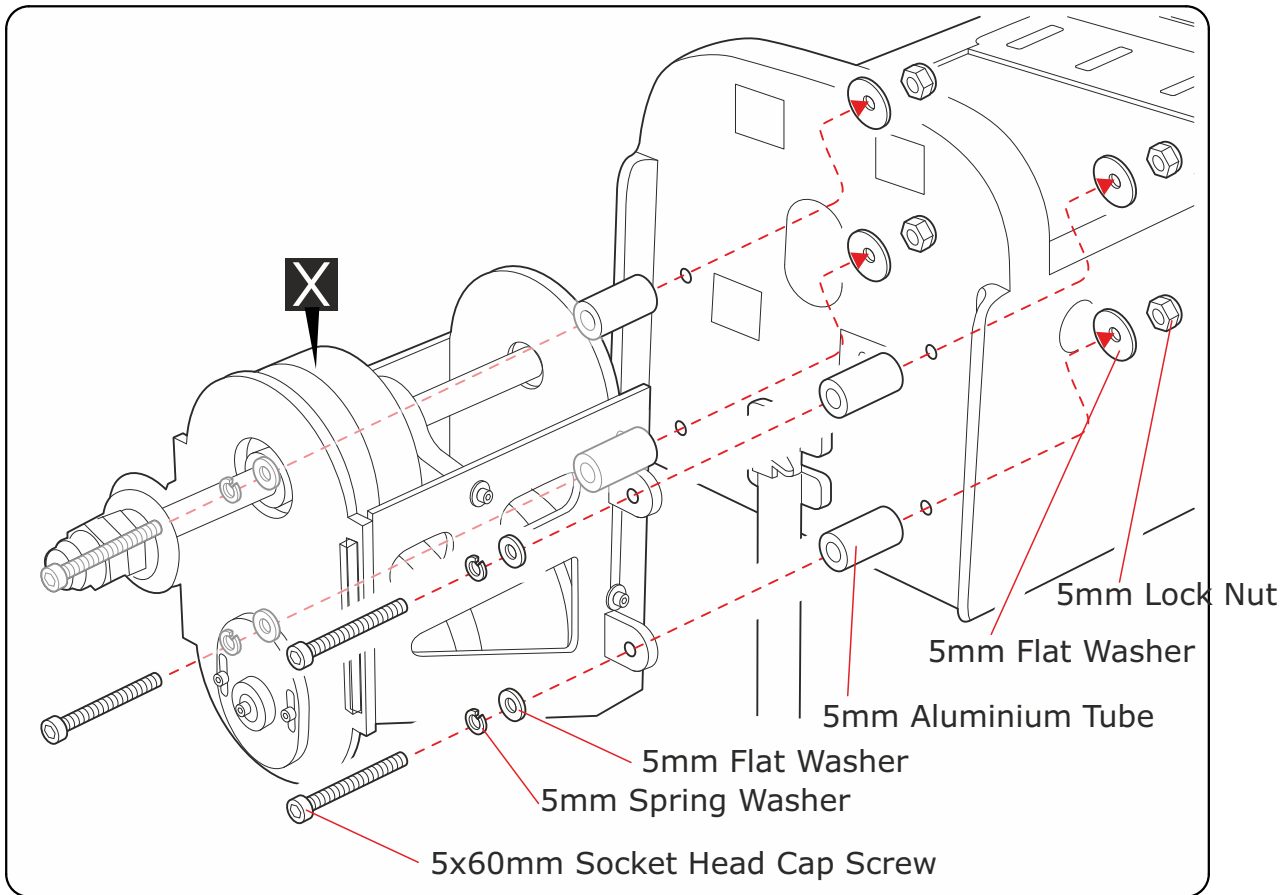
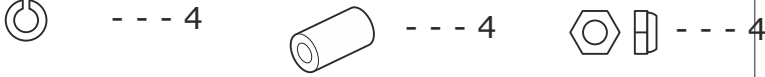

SCHWERPUNKT / CENTER OF GRAVITY

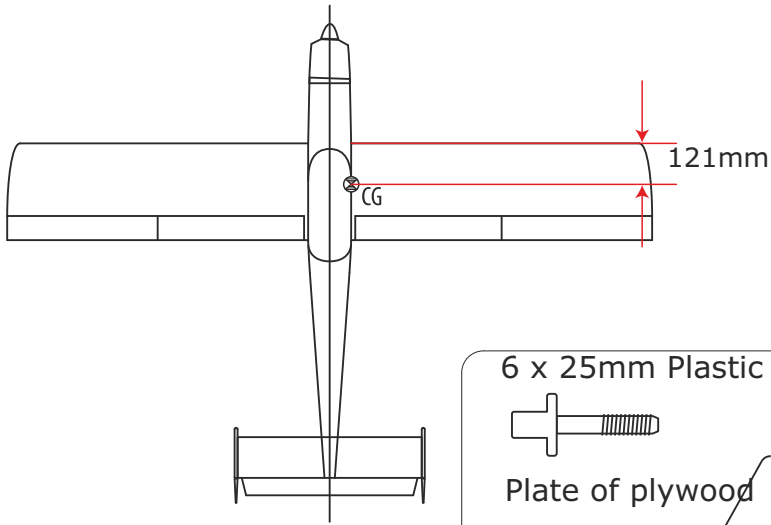

Abschließend muss der Schwerpunkt am Modell überprüft werden. Dazu werden alle Komponenten (auch der Akku!) im Modell montiert. Der Schwerpunkt liegt exakt **121mm** hinter der Naenleiste. Unterstützen Sie das Modell mit zwei Fingern exakt an diesen Punkten und beobachten Sie, wie das Modell auspendelt. Die Nase des Modells muss sich leicht nach unten neigen. Dann ist der Schwerpunkt optimal justiert.
 / Before the first flight you have to check the center of gravity. For doing so you have to mount all components (also the battery!) in to the model. The **CG** is placed **121mm** behind the nose cone of the main wing. Support the model exactly at the marked spots on the bottom side of the

6 x 25mm Plastic Screw	---	2	Ø 12x100mm Aluminium Tube	---	1
Plate of plywood	---	2	2000mm Wire	---	1

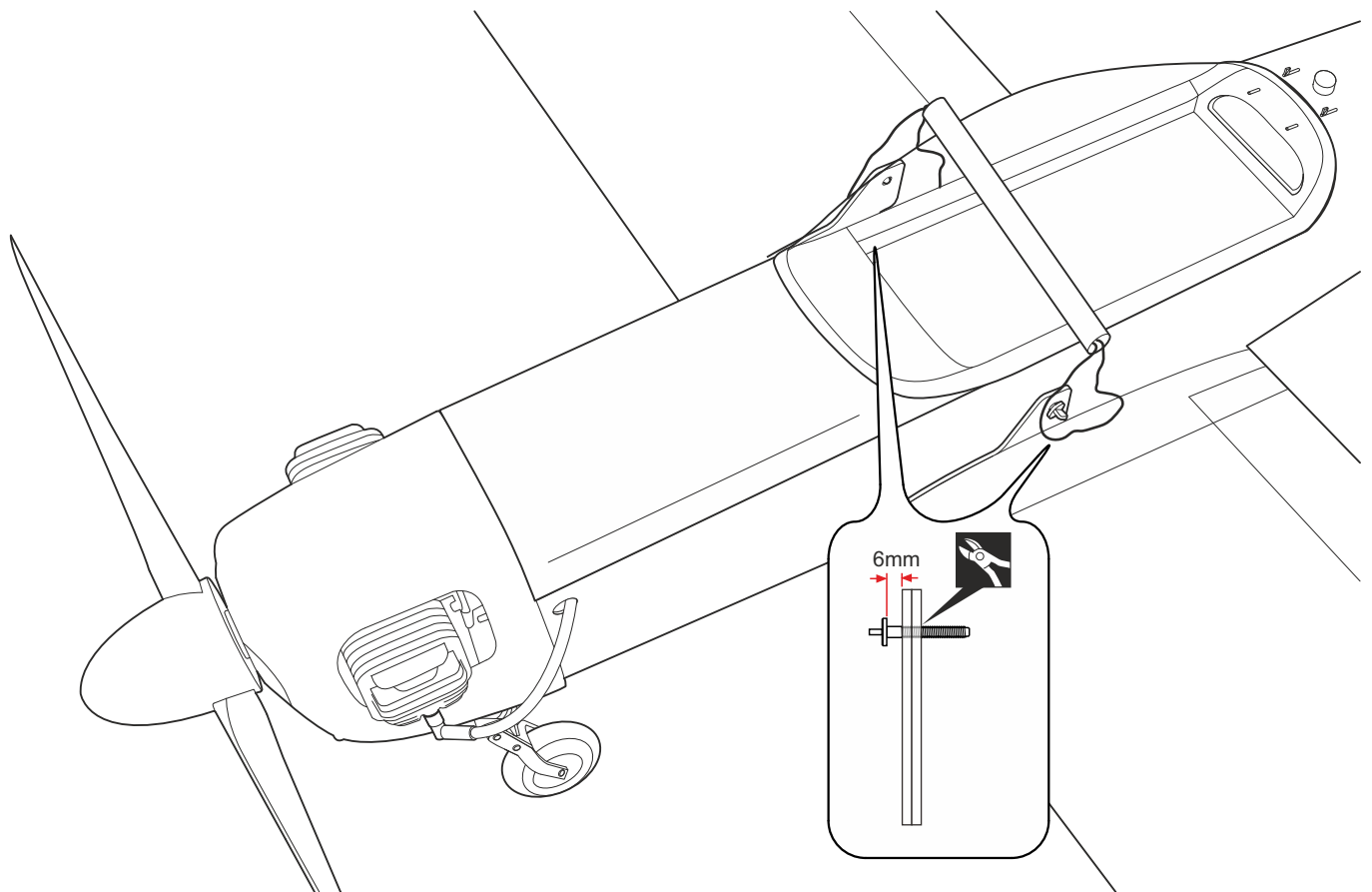

4. MONTAGE / ASSEMBLY

- ▶ In order to obtain the CG specified, reposition the receiver and other equipment.
- ▶ If not obtain the CG specified, add a weight and adjust.

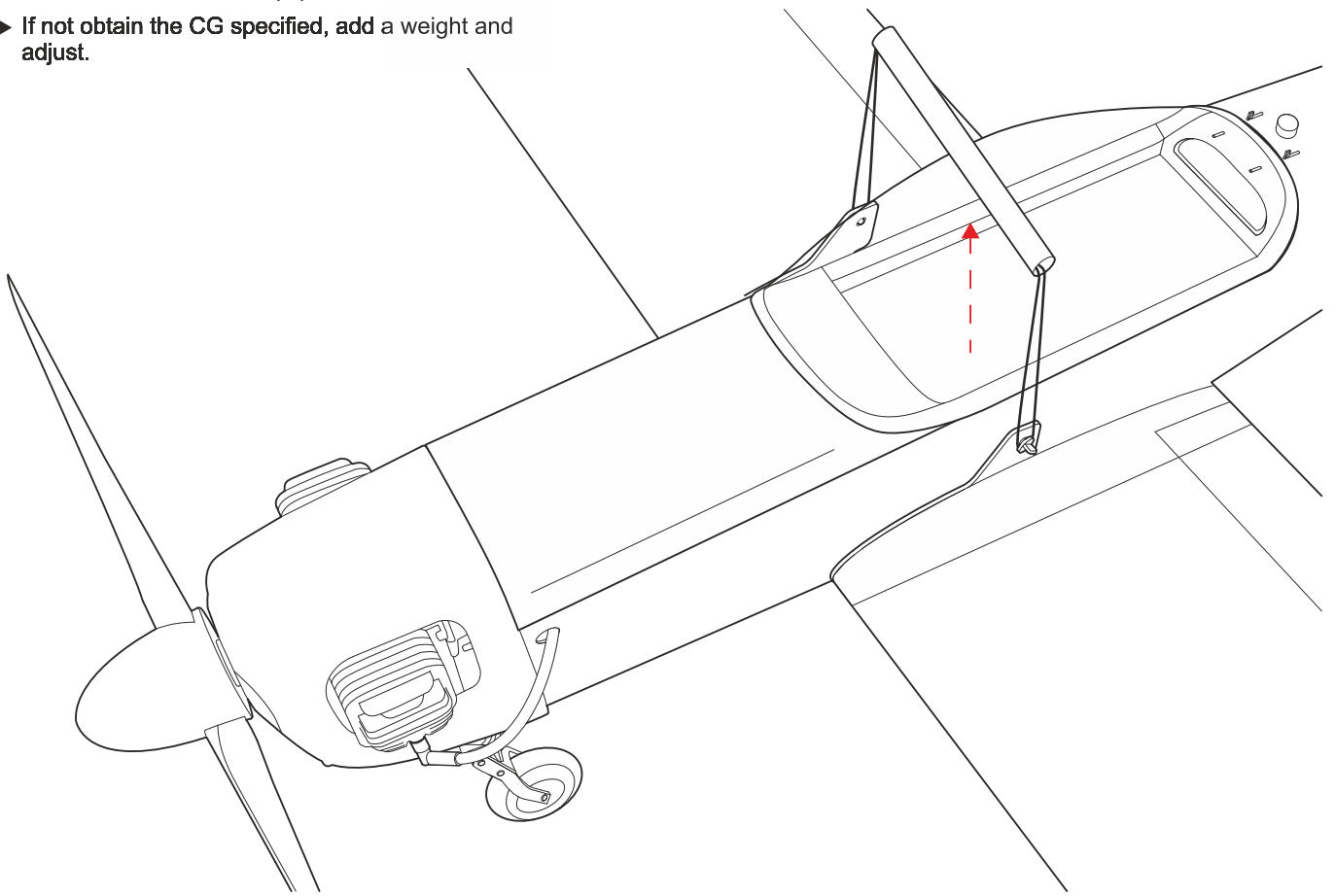

RUDERAUSSCHLÄGE / CONTROL THROWS

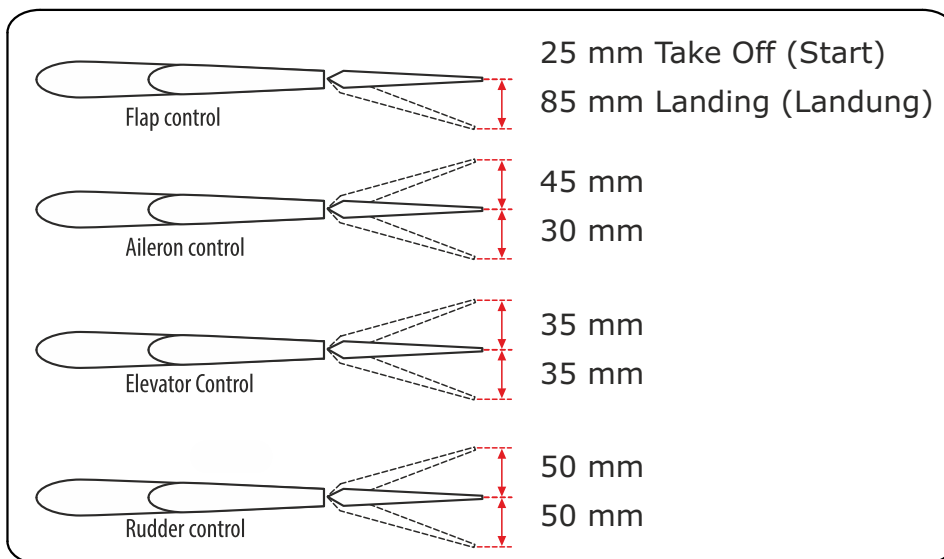

Top View

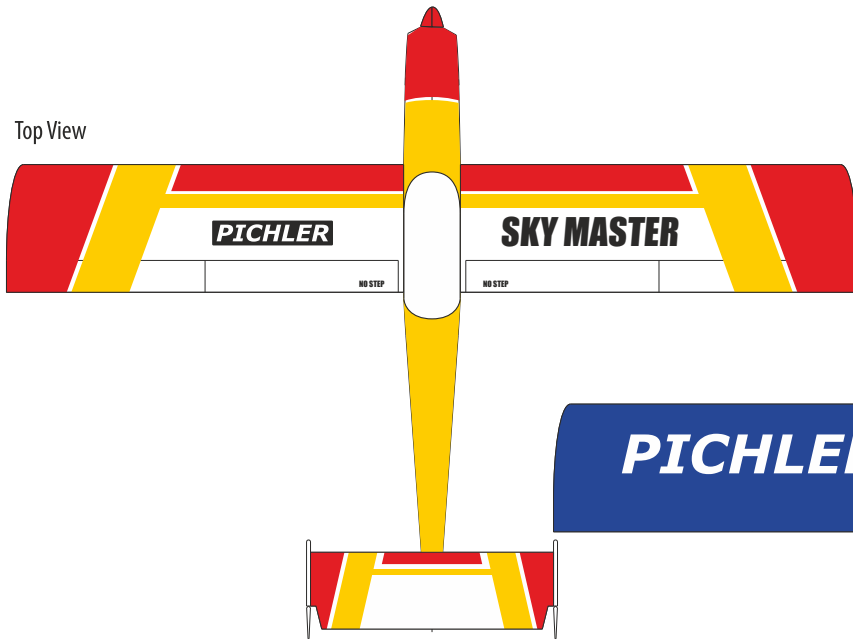

Bottom View

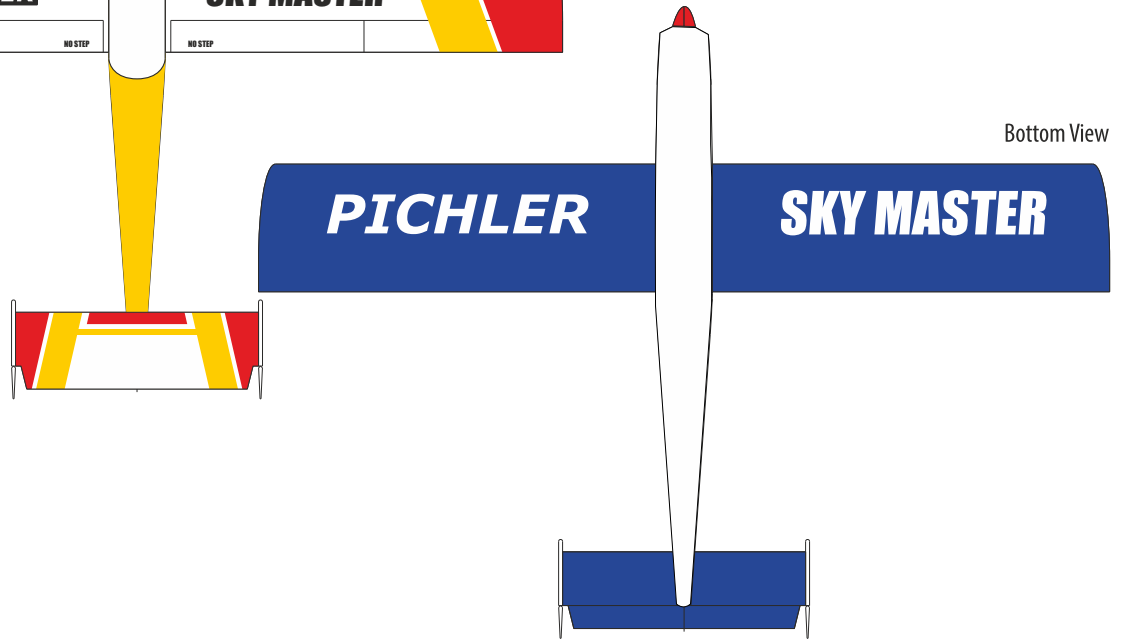

SideView: Left

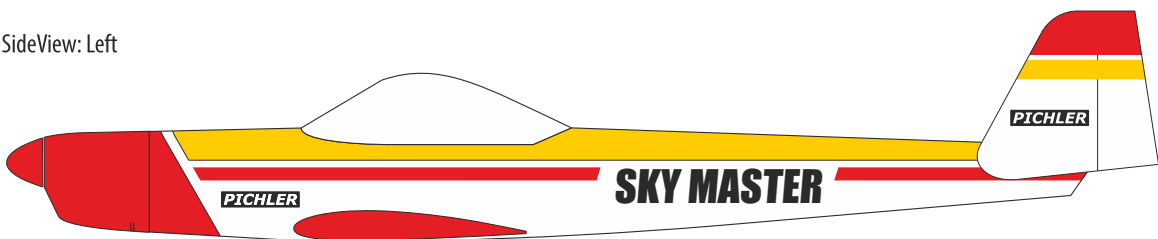

SideView: Right



5. HINWEISE ZUR BEDIENUNG / HOW TO USE

5.1 LAUFRICHTUNG DER RUDER / STEERING DIRECTION OF FLIGHT CONTROLS

Vor dem Erstflug des Modells muss unbedingt die Laufrichtung aller Ruder überprüft werden. / Before the first flight of the model, the steering direction must be checked carefully!

HÖHENRUDER / ELEVATOR

Wird der Höhenruderknüppel am Sender nach hinten gezogen, muss das Höhenruder nach oben ausschlagen. Wird der Höhenruderknüppel nach vorn gedrückt, muss das Höhenruder nach unten ausschlagen. / When you pull the elevator stick, the elevator has to move up, the model will climb. When you push the elevator stick, the elevator has to move down, the model will decline.

SEITENRUDER / RUDDER

Das Modell wird von hinten betrachtet. Wird der Seitenruderknüppel am Sender nach links bewegt, muss das Seitenruder nach links ausschlagen. Entsprechend umgekehrt erfolgt der Ausschlag für die andere Richtung. / Take a look to the model from behind. When you move the rudder stick to the left, the rudder has to move to the left. For the right side it works accordingly.

QUERRUDER / AILERON

Das Modell wird von hinten betrachtet. Wird der Querruderknüppel am Sender nach links bewegt, muss die linke Querruderklappe nach oben und die rechte Querruderklappe nach unten ausschlagen. Entsprechend umgekehrt erfolgen die Ausschläge für die andere Richtung. / Take a look to the model from behind. When you move the aileron stick to the left, the left flap has to move up and the right flap has to move down. For the right side it works accordingly.

MOTOR / MOTOR

Wird der Gasknüppel in die Leerlauf Position gebracht, muss der Motor stillstehen. Bei Vollgas muss der Motor seine maximale Drehzahl erreichen. / When you move the throttle stick to idle, the motor has to stop completely. Putting the throttle stick to full power, the motor has to reach its maximum rpm.

5.2 STARTVORGANG / TAKE OFF

- Starten Sie prinzipiell immer gegen den Wind! / Always start the model against the wind!
- Überprüfen Sie die Funktion aller Ruder vor jedem(!) Start. / Check all rudder controls before each(!) start.
- Geben Sie Vollgas und korrigieren Sie in Bodennähe nur mit kleinen Steuerausschlägen. / For take off always use maximum power. When you are near the ground only small control action is recommended.
- Steigen Sie in einem flachen Winkel. / Climb in a smooth angle.

5.3 LANDEVORGANG / LANDING PROCEDURE

- Drosseln Sie den Motor und fliegen Sie in ca. 40 m Entfernung mit Rückenwind parallel zur Landebahn. / Reduce motor power and fly parallel to the runway in a distance of about 40 meters.
- Fliegen Sie eine 90° Kurve in Richtung Landebahn und bauen Sie Höhe ab. / Turn 90° to the runway and decline continuously.
- Fliegen Sie erneut eine 90° Kurve, Sie fliegen nun direkt auf die Landebahn zu. Turn again 90° to the runway and decline continuously. You are now approaching the runway.
- Lassen Sie das Modell weiter sinken bis das Modell 1 m über der Landebahn schwebt. / Decline until you are about 1 meter over the runway.
- Ziehen Sie den Höhenruderknüppel etwas stärker und halten Sie ihn gezogen. / Pull the elevator carefully and keep it pulled.
- Je mehr sich das Modell dem Boden nähert, desto mehr muss der Höhenruderknüppel gezogen werden. Da das Modell ständig langsamer wird, setzt es sich praktisch von allein auf die Landebahn. / The closer you come to the ground the more you have to pull the elevator. As the model gets slower, it will land more or less automatically.

7. SERVICE & GEWÄHRLEISTUNG / SERVICE & WARRANTY

SERVICE & GEWÄHRLEISTUNG

Dieses Produkt unterliegt der gesetzlichen Gewährleistung. Die Haftung im Schadensfall ist begrenzt m Schadensfall ist begrenzt auf die Sache und gilt nicht für weiteres Zubehör. Für etwaige Folgeschäden übernehmen wir keine Haftung.

Im Servicefall wenden Sie sich zuerst bitte schriftlich (eMail, Brief oder Fax) mit einer aussagekräftigen Beschreibung des Problems sowie einer Kopie des Kaufbelegs an untenstehende Adresse. Sie verkürzen damit die Bearbeitungszeit erheblich. Die meisten Fragen und Probleme lassen sich am schnellsten per eMail klären.

UNERLAUBTE RÜCKSENDUNGEN WERDEN NICHT ANGENOMMEN!

Pichler Modellbau GmbH, 84307 Eggenfelden
mail@pichler.de www.pichler-modellbau.de

HINWEIS ZUR BATTERIEVERORDNUNG

Defekte Akkus sind Sondermüll und dürfen nicht über die Mülltonne entsorgt werden. Im Fachhandel, wo Sie die Akkus erworben haben, stehen Batterie- Recycling-Behälter für die Entsorgung bereit. Der Fachhandel ist zur Rücknahme verpflichtet.

Technische Änderungen sind ohne vorherige Ankündigungen möglich! Jeder Nachdruck, auch auszugsweise, bedarf unserer ausdrücklichen, schriftlichen Genehmigung.