



Instruction Manual Book

Item code: BH183

L-39 Albatros

95% PRE BUILT
ARF
ALMOST READY TO FLY



95% ALMOST READY TO FLY

**ALL Balsa - PLY WOOD CONSTRUCTION
COVERED IN A HEAT-SHRINK FILM WITH PRINTED.**

SPECIFICATION:

- Wingspan: 1,720 mm (67.7 in).
- Length: 2,163 mm (85 in).
- Weight: 9.6 – 10.5 kg (21 - 23 lbs).
- Wing area: 60.7 dm².
- Wing loading: 158 g/dm².
- Wing type: Naca Airfoil.
- Gear type: Electric Retract Gear (included) with controller box (included).

Parts listing required (not included):

- Radio: 8 channels minimum.
- Servo: 8 servos , size: (35 x 15)mm.
- Engine: Turbine Jet Engine with thrust 8kg (not included).

Recommended Battery set up (not included):

- Battery receiver: 2S- 7.4V - 3,200mAh.
2S- 7.4V - 2,200mAh.

TABLE OF CONTENTS

▶ Introduction.....	2	▶ Installing the vertical stabilizer.....	17
▶ Warranty.....	3	▶ Installing the vertical stabilizer servo.....	18
▶ Disclaimer.....	3	▶ Installing the wheel well.....	20
▶ Safety precaution.....	3	▶ Installing the fuselage.....	21
▶ Important building notes.....	3	▶ Installing the air intake.....	21
▶ Suggestion.....	3	▶ Installing the wings to fuselage.....	22
▶ Flight warnings.....	3	▶ Installing the nose gear retract.....	23
▶ Covering tools.....	4	▶ Installing the horizontal stabilizer to fuselage...25	
▶ Adhesives and required tools.....	4	▶ Installing the vertical stabilizer to fuselage...26	
▶ Academy of Model Aeronautics National Model Aircraft Safety Code.....	4	▶ Installing the engine.....	27
▶ Parts listing (not included).....	6	▶ Installing the fuel tank.....	28
▶ Tools & supplies needed.....	6	▶ Installing the receiver, battery, controller box and switch.....	31
▶ Symbols used throughout this instruction manual comprise.....	6	▶ Installing cockpit fuselage.....	31
▶ Installing the ailerons and flaps.....	8	▶ Balancing.....	33
▶ Installing the aileron and flap servo.....	9	▶ Lateral balance.....	33
▶ Installing the wings tip.....	13	▶ Control throws.....	35
▶ Installing the main landing gear.....	14	▶ Electric retract system.....	36
▶ Installing horizontal stabilizer.....	15	▶ Flight preparation pre flight check.....	37
▶ Installing the horizontal stabilizer servo....	15	▶ For your radio installation Basic connection for airplane And adjustment of servos.....	37
▶		▶ Main gear dimensional detail.....	38
		▶ Nose gear dimensional detail.....	38
		▶ Exploded view.....	39
		▶ Decoration.....	40

INTRODUCTION

Thank you for purchasing Black Horse Model products. With over 18 years experience in production and fly testing, Black Horse Model is committed to bring the best quality products and good service to customers. Along with a team of creative engineers and skilled workers, we will always accompany with customers by our great experiences, fully enthusiasm... which will burn our passion!! Joining with us to explore and conquer challenges in the sky ...

Your satisfaction is our success. Please read through this manual before starting construction.

Academy of Model Aeronautics: If you are not already a member of the AMA, please join! The AMA is the governing body of model aviation and membership provides liability insurance coverage, protects modelers' rights and interests and is required to fly at most R/C sites.

Academy of ModelAeronautics
5151 East Memorial Drive Muncie IN 47302-9252

Tele. (800) 435-9262
Fax. (765) 741-0057

Or via the Internet at: <http://www.modelaircraft.org>



WARRANTY

Black Horse Model guarantees the component parts in this kit to be free from defects in both material and workmanship at the date of purchase by the purchaser.

This warranty does not cover cosmetic damage or damage due to acts of God, accident, misuse, abuse, negligence, commercial use, or modification of or to any part of the Product.

This warranty does not cover damage due to improper installation, operation, maintenance, or attempted repair by anyone other than Black Horse Model.

Further, Black Horse Model reserves the right to change or modify this warranty without notice.

DISCLAIMER

Read this disclaimer carefully before using this product. Please strictly follow the instruction manual to assemble and use this.

In that Black Horse Model has no control over the final assembly or material used for final assembly, Black Horse Model is not responsible for loss of use, or other incidental or consequential damages.

Furthermore, Black Horse Model cannot be held liable for personal injury or property damage caused by the use or misuse of Black Horse Model products. By the act of using the user-assembled products, the user accepts all resulting liability.

SAFETY PRECAUTION

- This is not a toy and pilots must be over the age of 14
- Be sure that no other flyers are using your radio frequency.
- Do not smoke near fuel
- Store fuel in a cool, dry place, away from children and pets.
- Wear safety glasses.
- The glow plug clip must be securely attached to the glow plug.
- Do not flip the propeller with your fingers.
- Keep loose clothing and wires away from the propeller.
- Do not start the engine if people are near. Do not stand in line with the side of the propeller.
- Make engine adjustments from behind the propeller only. Do not reach around the spinning propeller.
- Moisture causes damage to electronics. Avoid water exposure to all equipment not specifically designed and protected for this purpose.

IMPORTANT BUILDING NOTES

- Please trial fit all the parts. Make sure you have the correct parts and that they fit and are aligned properly before gluing! This will assure proper assembly. This kit is hand made from natural materials, every plane is unique and minor adjustments may have to be made. However, you should find the fit superior and assembly simple.
- The painted and plastic parts used in this kit are fuel proof. However, they are not tolerant of many harsh chemicals including the following: paint thinner, C/A glue accelerator, C/A glue debonder and acetone. Do not let these chemicals come in contact with the colors on the covering and the plastic parts.
- Some parts included in this kit such as the cowl or wheel pants are made of fiberglass, the fibers of which may cause eye, skin and respiratory tract irritation. Never blow into a part to remove fiberglass dust, as the dust will blow back into your eyes. Always wear safety goggles, a particle mask and rubber gloves when grinding, drilling and sanding fiberglass parts. Vacuum the parts and the work area thoroughly after working with fiberglass parts.

SUGGESTION

To avoid scratching your new airplane, do not unwrap the pieces until they are needed for assembly. Cover your workbench with an old towel or brown paper, both to protect the aircraft and to protect the table. Keep a couple of jars or bowls handy to hold the small parts after you open the bag.

FLIGHT WARNINGS

- Always operate in open areas, away from factories, hospitals, schools, buildings and houses etc.
- NEVER fly your aircraft close to people or built up areas.
- NEVER fly near power lines, aerials or other dangerous areas including airports, motorways etc.
- NEVER fly in wet conditions or on windy or stormy days.
- ALWAYS adjust the engine from behind the propeller, and do not allow any part of your body to be in line with the propeller.
- THE PROPELLER IS DANGEROUS Keep fingers, clothing (ties, shirt sleeves, scarves) or any other loose objects that could be caught or drawn in, away from the propeller. Take care at ALL times.
- NEVER use damaged or deformed propellers or spinners.
- Keep all onlookers (especially small children and animals) well back from the area of operation. This is a flying aircraft, which will cause serious injury in case of impact with a person or animal.
- DO NOT dispose of empty fuel containers on a fire, this can lead to an explosion.

FLIGHT WARNINGS

- When ready to fly, first extend the transmitter aerial.
- Switch on the transmitter.
- Switch on the receiver.
- Check that the wings are correctly fitted to the fuselage.
- Operate the control sticks on the transmitter and check that the control surfaces move freely and in the CORRECT directions.
- Check that the transmitter batteries have adequate power.
- ALWAYS take off into the wind.
- If the model does not respond correctly to the controls, land it as soon as possible and correct the fault.
- ALWAYS land the model INTO the wind, this ensures that the model lands at the slowest possible speed.
- Switch off the receiver.
- Switch off the transmitter.
- Empty the fuel tank after flying, fuel left in the tank can cause corrosion and lead to engine problems.

COVERING TOOLS

- Top Flite® MonoKote® Sealing Iron
- Top Flite Hot Sock Iron Cover
- Top Flite MonoKote Trim Seal Iron
- Top Flite MonoKote Heat Gun

ADHESIVES AND REQUIRED TOOLS

- Thin CA
- 30-minute epoxy
- 6-minute epoxy
- Threadlocker thread locking cement
- Mixing sticks
- Mixing cups (GPMR8056)
- Epoxy brushes
- Denatured alcohol
- Canopy Glue
- Felt-tipped pen or pencil
- Flat screwdriver
- Adjustable wrench
- Drill
- Hobby knife
- Masking tape
- Phillips screwdriver (large)
- Phillips screwdriver (small)
- Ruler
- Sandpaper
- Soldering iron
- Solder
- Hex wrench
- Drill bit: 1/16-inch (1.5mm), 5/64-inch (2mm), 1/8-inch (3,2mm), 3/16-inch (4,8mm), 11/64-inch (4.5mm), 13/64-inch (5,2mm), 1/4-inch (6,4mm)

Academy of Model Aeronautics National Model Aircraft Safety Code

Effective January 1, 2014

A. GENERAL: A model aircraft is a non-human-carrying aircraft capable of sustained flight in the atmosphere. It may not exceed limitations of this code and is intended exclusively for sport, recreation, education and/or competition. All model flights must be conducted in accordance with this safety code and any additional rules specific to the flying site.

1. Model aircraft will not be flown:
 - (a) In a careless or reckless manner.
 - (b) At a location where model aircraft activities are prohibited.
2. Model aircraft pilots will:
 - (a) Yield the right of way to all human-carrying aircraft.
 - (b) See and avoid all aircraft and a spotter must be used when appropriate. (AMA Document #540-D.)
 - (c) Not fly higher than approximately 400 feet above ground level within three (3) miles of an airport without notifying the airport operator.
 - (d) Not interfere with operations and traffic patterns at any airport, heliport or seaplane base except where there is a mixed use agreement.
 - (e) Not exceed a takeoff weight, including fuel, of 55 pounds unless in compliance with the AMA Large Model Airplane program. (AMA Document 520-A.)
 - (f) Ensure the aircraft is identified with the name and address or AMA number of the owner on the inside or affixed to the outside of the model aircraft. (This does not apply to model aircraft flown indoors.)
 - (g) Not operate aircraft with metal-blade propellers or with gaseous boosts except for helicopters operated under the provisions of AMA Document #555.
 - (h) Not operate model aircraft while under the influence of alcohol or while using any drug that could adversely affect the pilot's ability to safely control the model.
 - (i) Not operate model aircraft carrying pyrotechnic devices that explode or burn, or any device which propels a projectile or drops any object that creates a hazard to persons or property.





Exceptions:

- Free Flight fuses or devices that burn producing smoke and are securely attached to the model aircraft during flight.
- Rocket motors (using solid propellant) up to a G-series size may be used provided they remain attached to the model during flight. Model rockets may be flown in accordance with the National Model Rocketry Safety Code but may not be launched from model aircraft.

- Officially designated AMA Air Show Teams (AST) are authorized to use devices and practices as defined within the Team AMA Program Document. (AMA Document #718.)
- (j) Not operate a turbine-powered aircraft, unless in compliance with the AMA turbine regulations. (AMA Document #510-A.)
- 3. Model aircraft will not be flown in AMA sanctioned events, air shows or model demonstrations unless:
 - (a) The aircraft, control system and pilot skills have successfully demonstrated all maneuvers intended or anticipated prior to the specific event.
 - (b) An inexperienced pilot is assisted by an experienced pilot.
- 4. When and where required by rule, helmets must be properly worn and fastened. They must be OSHA, DOT, ANSI, SNELL or NOCSAE approved or comply with comparable standards.
- B. RADIO CONTROL (RC)
 - 1. All pilots shall avoid flying directly over unprotected people, vessels, vehicles or structures and shall avoid endangerment of life and property of others.
 - 2. A successful radio equipment ground-range check in accordance with manufacturer's recommendations will be completed before the first flight of a new or repaired model aircraft.
 - 3. At all flying sites a safety line(s) must be established in front of which all flying takes place. (AMA Document #706.)
 - (a) Only personnel associated with flying the model aircraft are allowed at or in front of the safety line.
 - (b) At air shows or demonstrations, a straight safety line must be established.
 - (c) An area away from the safety line must be maintained for spectators.
 - (d) Intentional flying behind the safety line is prohibited.
 - 4. RC model aircraft must use the radio-control frequencies currently allowed by the Federal Communications Commission (FCC). Only individuals properly licensed by the FCC are authorized to operate equipment on Amateur Band frequencies.
 - 5. RC model aircraft will not knowingly operate within three (3) miles of any pre-existing flying site without a frequency-management agreement. (AMA Documents #922 and #923.)
 - 6. With the exception of events flown under official AMA Competition Regulations, excluding takeoff and landing, no powered model may be flown outdoors closer than 25 feet to any individual, except for the pilot and the pilot's helper(s) located at the flightline.
 - 7. Under no circumstances may a pilot or other person touch an outdoor model aircraft in flight while it is still under power, except to divert it from striking an individual.
 - 8. RC night flying requires a lighting system providing the pilot with a clear view of the model's attitude and orientation at all times. Hand-held illumination systems are inadequate for night flying operations.
 - 9. The pilot of an RC model aircraft shall:
 - (a) Maintain control during the entire flight, maintaining visual contact without enhancement other than by corrective lenses prescribed for the pilot.
 - (b) Fly using the assistance of a camera or First-Person View (FPV) only in accordance with the procedures outlined in AMA Document #550.
 - (c) Fly using the assistance of autopilot or stabilization system only in accordance with the procedures outlined in AMA Document #560.
- C. FREE FLIGHT
 - 1. Must be at least 100 feet downwind of spectators and automobile parking when the model aircraft is launched.
 - 2. Launch area must be clear of all individuals except mechanics, officials, and other fliers.
 - 3. An effective device will be used to extinguish any fuse on the model aircraft after the fuse has completed its function.
- D. CONTROL LINE
 - 1. The complete control system (including the safety thong where applicable) must have an inspection and pull test prior to flying.
 - 2. The pull test will be in accordance with the current Competition Regulations for the applicable model aircraft category.
 - 3. Model aircraft not fitting a specific category shall use those pull-test requirements as indicated for Control Line Precision Aerobatics.
 - 4. The flying area must be clear of all utility wires or poles and a model aircraft will not be flown closer than 50 feet to any above-ground electric utility lines.
 - 5. The flying area must be clear of all nonessential participants and spectators before the engine is started.

PARTS LISTING (NOT INCLUDED).

Servo extension leads.

-  2 pcs.
-  920mm 3 pcs.
-  330mm 2 pcs.
-  220mm 9 pcs.
-  420mm 4 pcs.

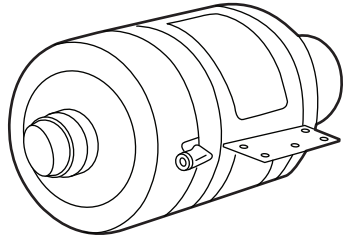

Turbine Jet Engine with thrust 8kg

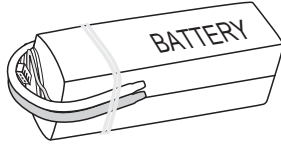



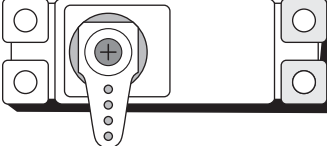





LiPo: 2S- 7.4V - 3,200mAh.....2 Packs
 LiPo: 2S- 4V - 2,200mAh.....2 Packs

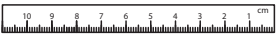



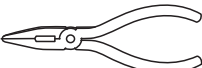

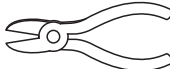







Servos size: (35x15)mm.
 Torque: 6V(4.6kg-cm), 7.4V(8kg-cm).... 8pcs

Ø20x1600mm
 600 Deg High Temperature Braided Soft Chemical Fiber Tubing
 ----- 1

TOOLS & SUPPLIES NEEDED

 Medium C/A glue	 Straight edge ruler.	 30 minute epoxy. 5 minute epoxy.	 Hex Wrench.	 Hand or electric drill.
 Threadlocker (screw cement).	 2 bender plier	 Screw driver	Some more tools. ■ Assorted drill bits. ■ Masking tape. ■ Paper towels. ■ Rubbing alcohol ■ 90° square or builder's triangle.	
 Modeling knife.	 Wire cutters.			

Symbols used throughout this instruction manual, comprise:

 Cut off excess.	 Apply threadlocker (screw cement).	 Must be purchased separately!
 Cut off shaded portion carefully.	 Apply instant glue (C.A glue, super glue).	 Ensure smooth, non-binding movement when assembling.
 Pay close attention here.	 Apply epoxy glue.	 Drill holes using the stated. (in this case 1.5mm Ø).
 Take particular care here.	 Assemble left and right sides the same way.	 The number of times the same way Assembly (in this case twice).
 Warning! ► Set all screws securely. If they come off during flight you will lose control of your aircraft!		

1: Fuselage set. 2: Cockpit set. 3: Wing set. 4: Horizontal stabilizer set 5: Vertical stabilizer set.

6: Nose gear set. 7: Main gear set. 8: Fuel tank set. 9: Engine set. 10: CG set. 11: Controller box set. 12: Decal.

1

Wheel Well L R ---1

Air Intake L R ---1

Ø12x198mm Aluminium Tube ---3

4x12mm Socket Head Cap Screw ---4

4mm Spring Washer ---4

4mm Flat Washer ---4

2

Canopy ---1

Pilot ---1

Centre Stick ---1

2x10mm Tp Screw ---7

3

44mm Pinned Hinge Aileron ---6

67mm Pinned Hinge Flap ---8

6x50mm Aluminium ---4

3x12mm Tp Screw ---8

Horn ---2

2.6x75mm Pushrod Aileron ---2

2.6x100mm Pushrod Flap ---2

Ball Link ---8

Horn ---2

3x12mm Button Head Cap Screw ---8

3mm Lock Nut ---4

3mm Flat Washer ---4

2x10mm Tp Screw ---16

Ø20x765mm Fiber Carbon Tube ---1

Wing Tip ---2

4x12mm Socket Head Cap Screw ---4

Spring Washer ---4

4

Horn ---2

2.6x50mm Pushrod Elevator ---2

Ball Link ---4

3x12mm Button Head Cap Screw ---4

3mm Flat Washer ---4

3mm Lock Nut ---4

44mm Pinned Hinge Aileron ---6

6x50mm Aluminium ---2

Ø12x345mm Fiber Carbon Tube ---1

5

Horn ---1

2.6x45mm Pushrod Elevator ---1

Ball Link ---2

3x12mm Button Head Cap Screw ---2

3mm Flat Washer ---2

3mm Lock Nut ---2

Ø12x172mm Fiber Carbon Tube ---1

44mm Pinned Hinge Aileron ---4

6x50mm Aluminium ---1

2.6x28mm Pushrod ---1

Ball Link ---2

4x16mm Button Head Cap Screw ---4

4mm Spring Washer ---4

3x12mm Button Head Cap Screw ---1

3mm Flat Washer ---1

3mm Lock Nut ---1

3x8mm Button Head Cap Screw ---4

7

L R ---1

4x16mm Button Head Cap Screw ---8

4mm Spring Washer ---8

8

Clunks ---1

Rubber ---1

3x25mm Screw ---1

Aluminium ---1

4x55mm Copper Tube ---2

4x87mm Copper Tube ---1

Main Fuel Tank ---1

9

Exhaust Tube ---1

3x15mm Tp Screw ---10

10

6 x 25mm Plastic Screw ---2

Plate of plywood CG ---2





2000mm Wire ---1

11

Controller Box ---1

12

INSTALLING THE AILERONS AND FLAPS

44mm Pinned Hinge Aileron 	--- 6	3x12mm Tp Screw 	--- 8
67mm Pinned Hinge Flap 	--- 8	Horn 	--- 2
6x50mm Aluminium 	--- 4		

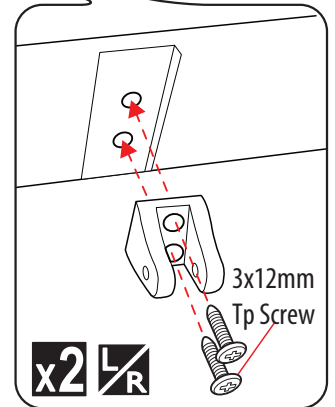
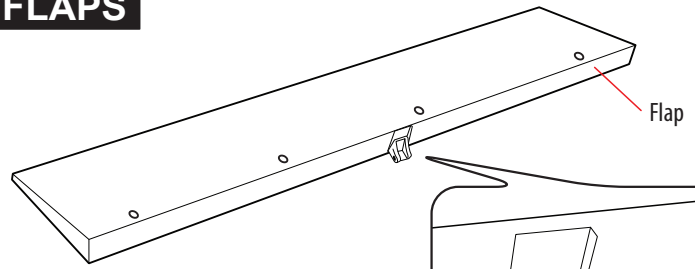

Bottom view

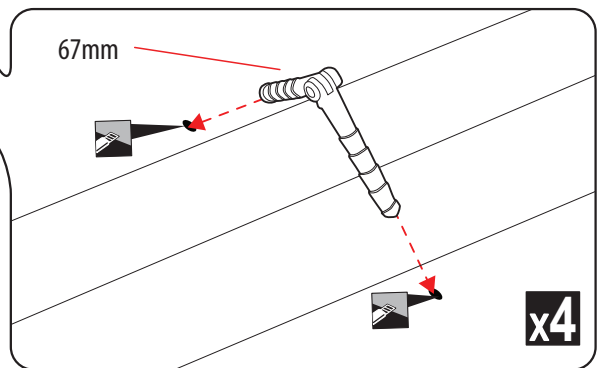
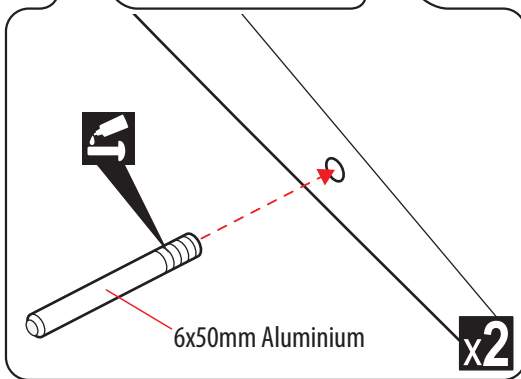
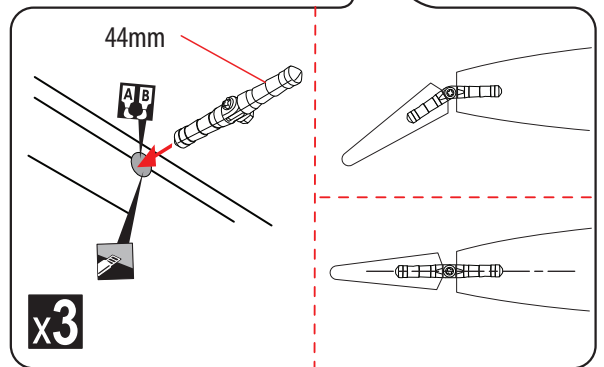
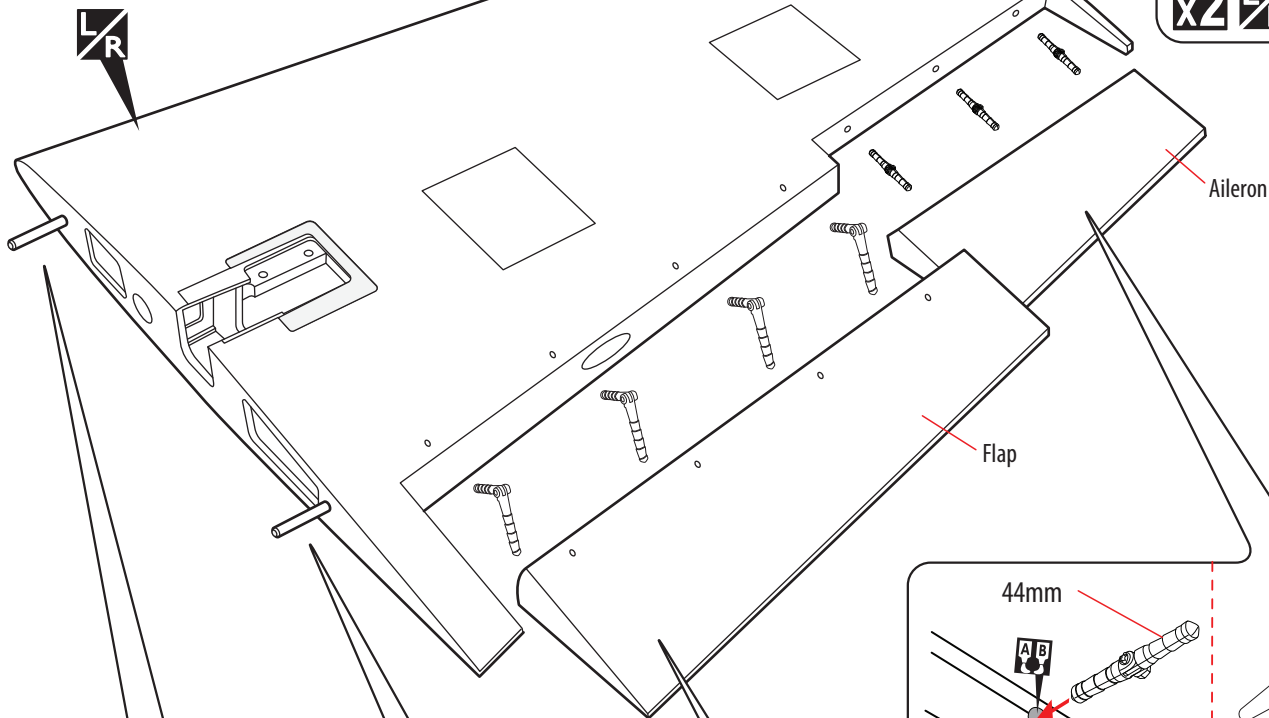

L/R Assemble left and right sides the same way.

x2 The number of times the same way Assembly (in this case twice).

A/B Apply epoxy glue.

INSTALLING THE AILERON AND FLAP SERVOS

- 2.6x75mm Pushrod Aileron --- 2
- 2.6x100mm Pushrod Flap --- 2
- Ball Link --- 8
- Horn --- 8
- Horn --- 2
- 3x12mm Button Head Cap Screw --- 8
- 3mm Flat Washer --- 4
- 3mm Lock Nut --- 4
- 2x10mm Tp Screw --- 16

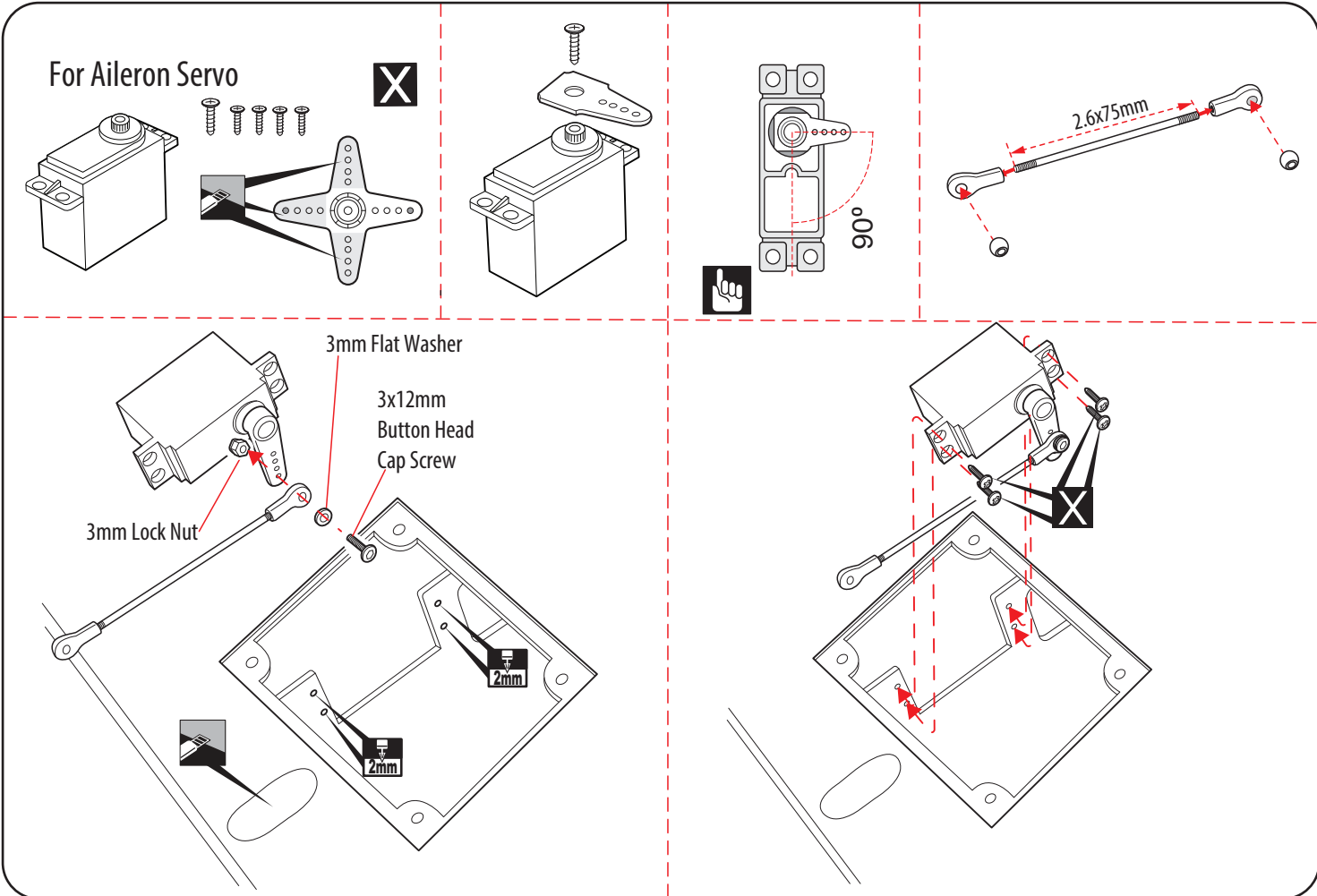
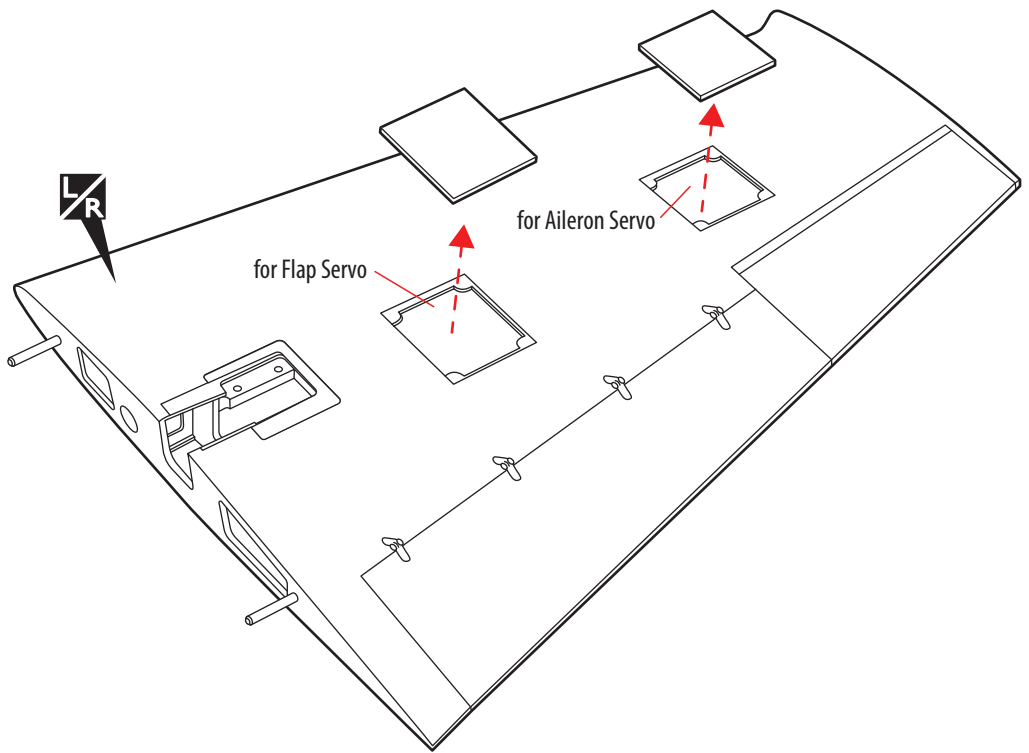

Cut off shaded portion carefully.
 Apply threadlocker (screw cement).
 Must be purchased separately!
 Drill holes using the stated. (in this case 2mm \varnothing 9

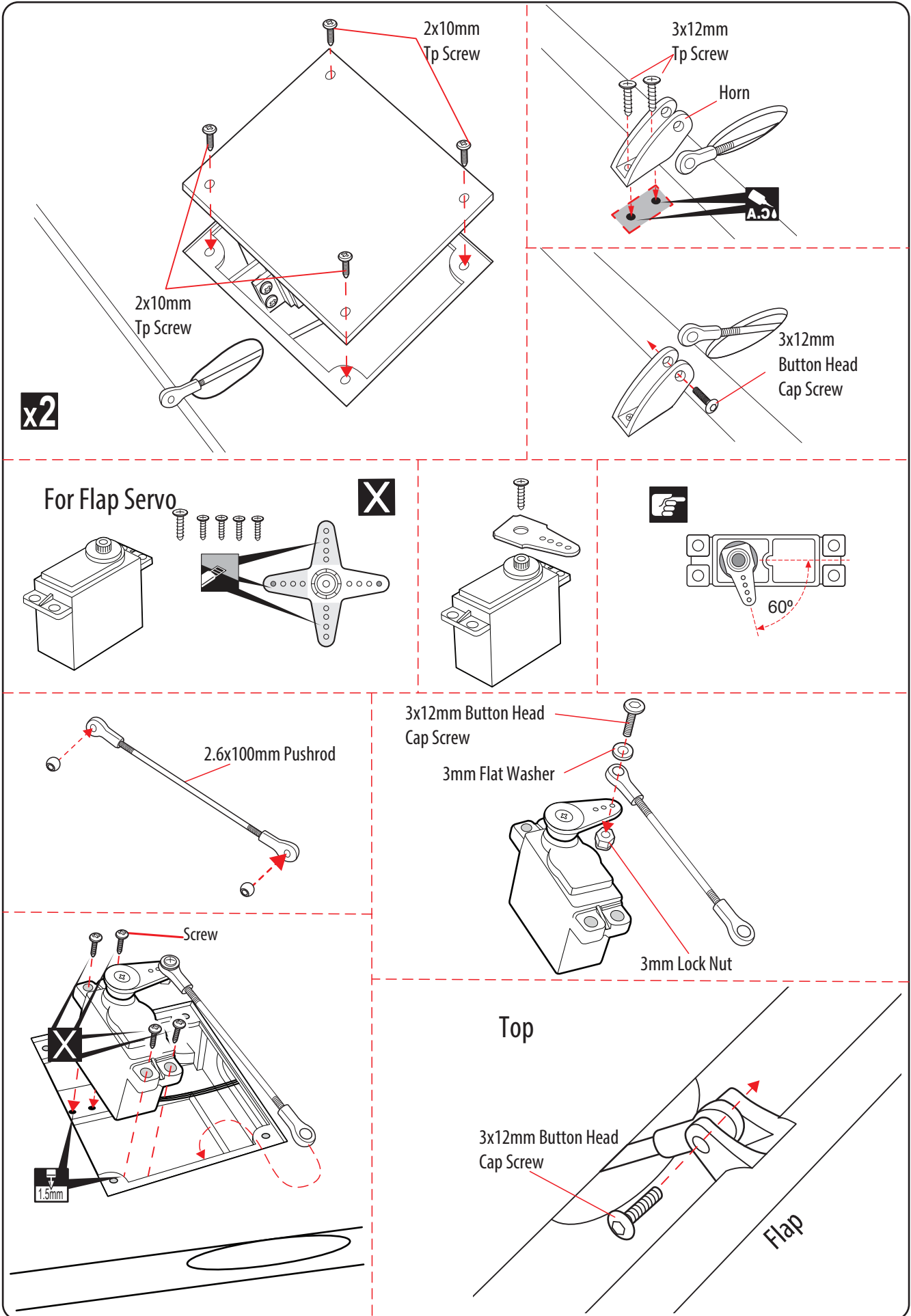

x2

For Flap Servo

X

Hand icon

60°

2.6x100mm Pushrod

3x12mm Button Head Cap Screw

3mm Flat Washer

3mm Lock Nut

Top

3x12mm Button Head Cap Screw

Flap

1.5mm



Drill holes using the stated. (in this case 1.5mm Ø).

x2

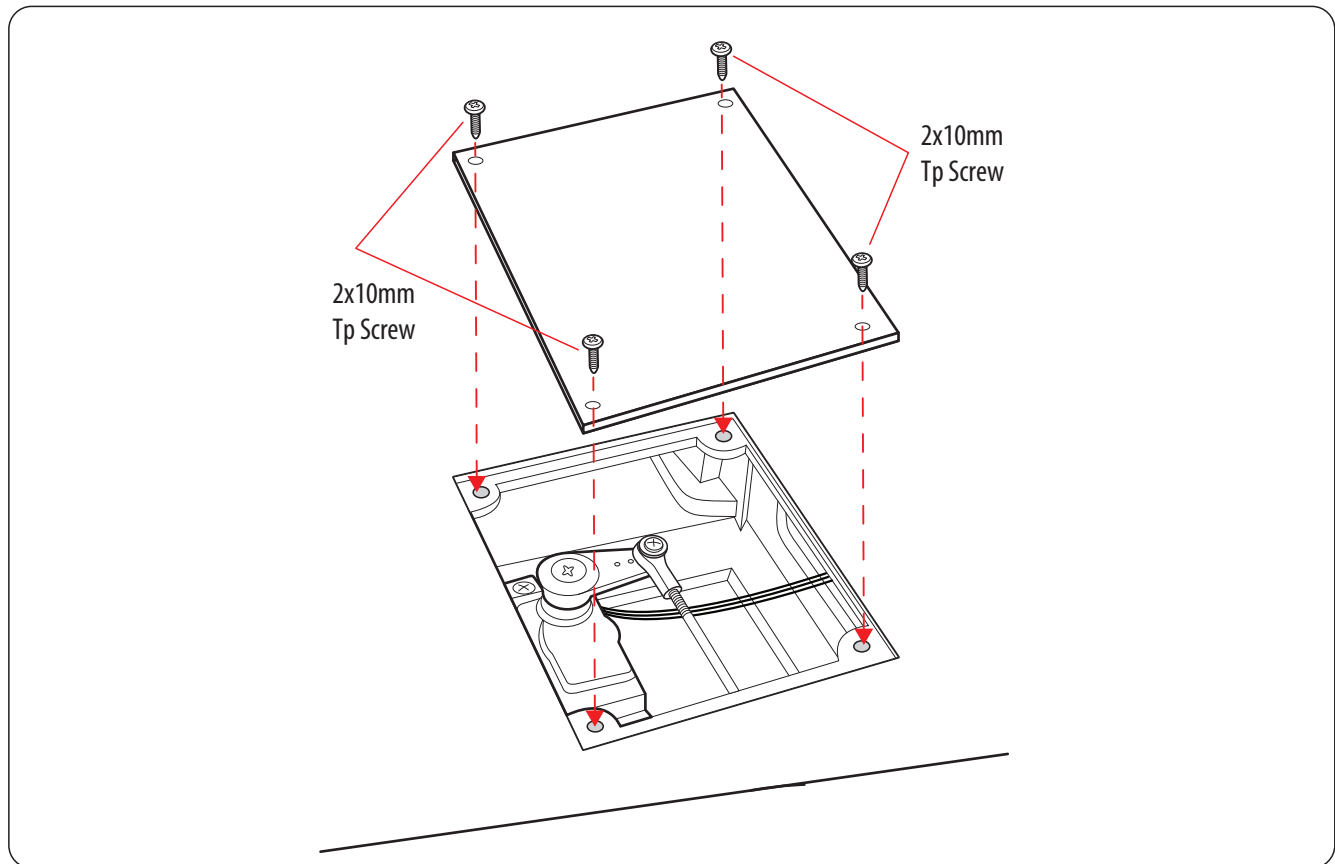

The number of times the same way Assembly (in this case twice).

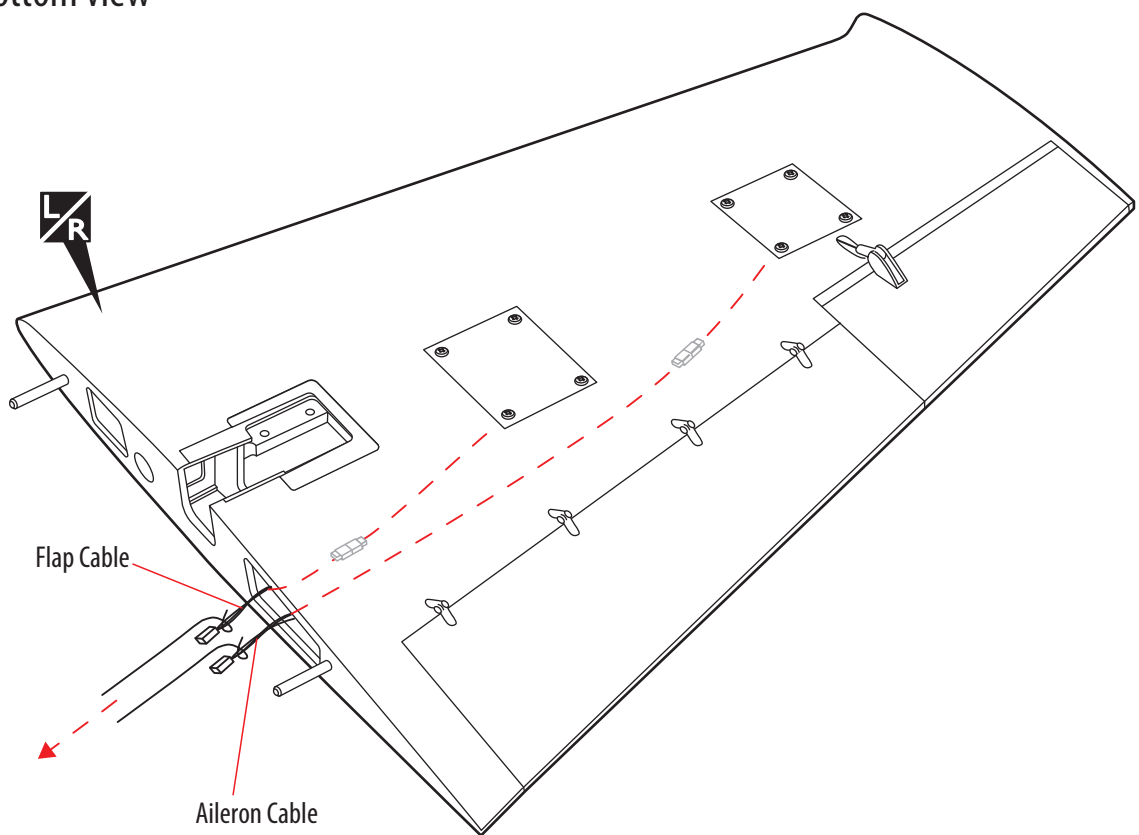

Bottom view

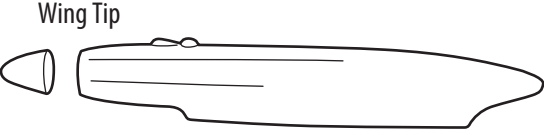

 Assemble left and right sides the same way.

 Wing Tip ---2	 4x12mm Button Head Cap Screw ---4	 Spring Washer ---4
---	--	---

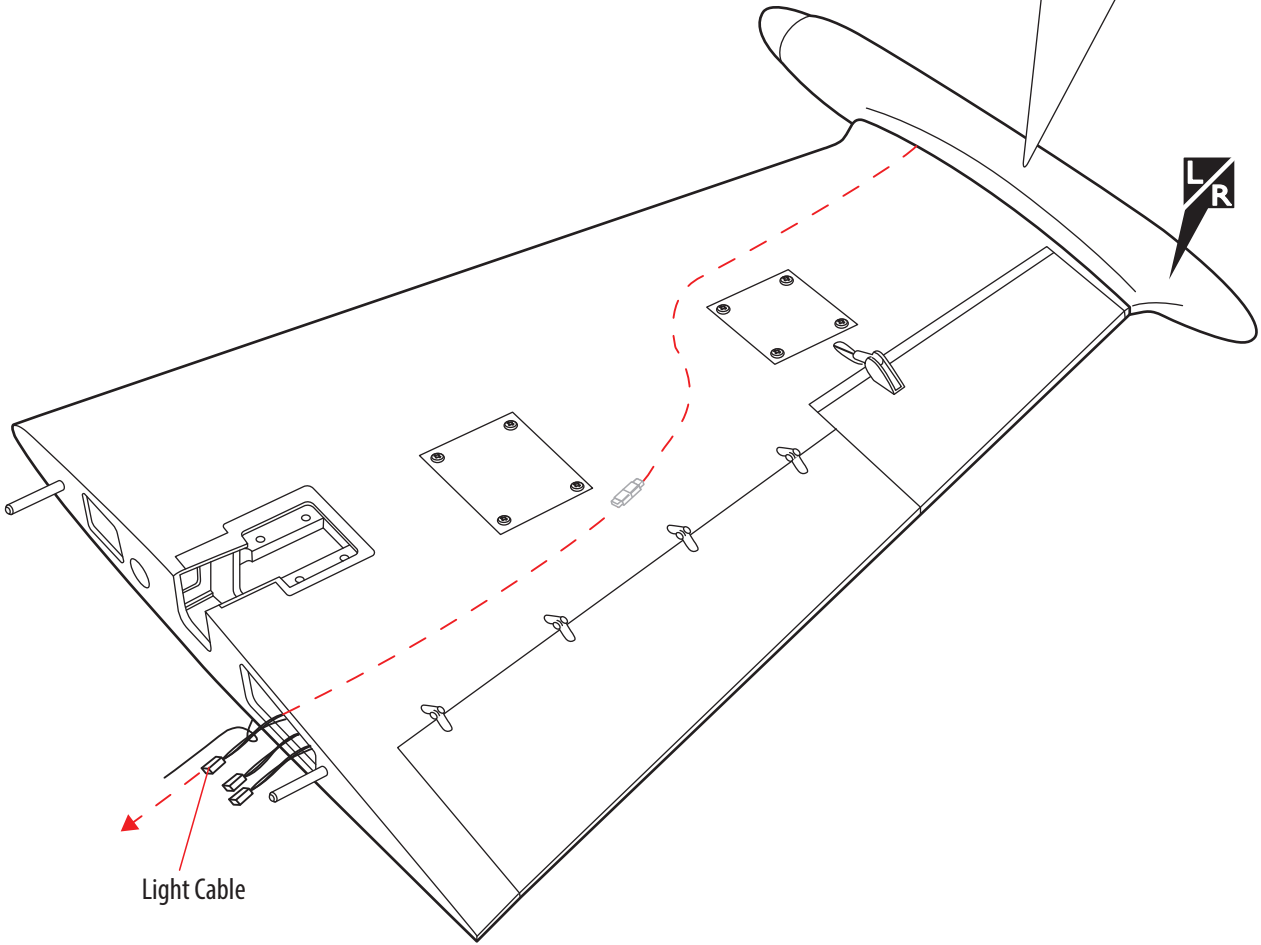
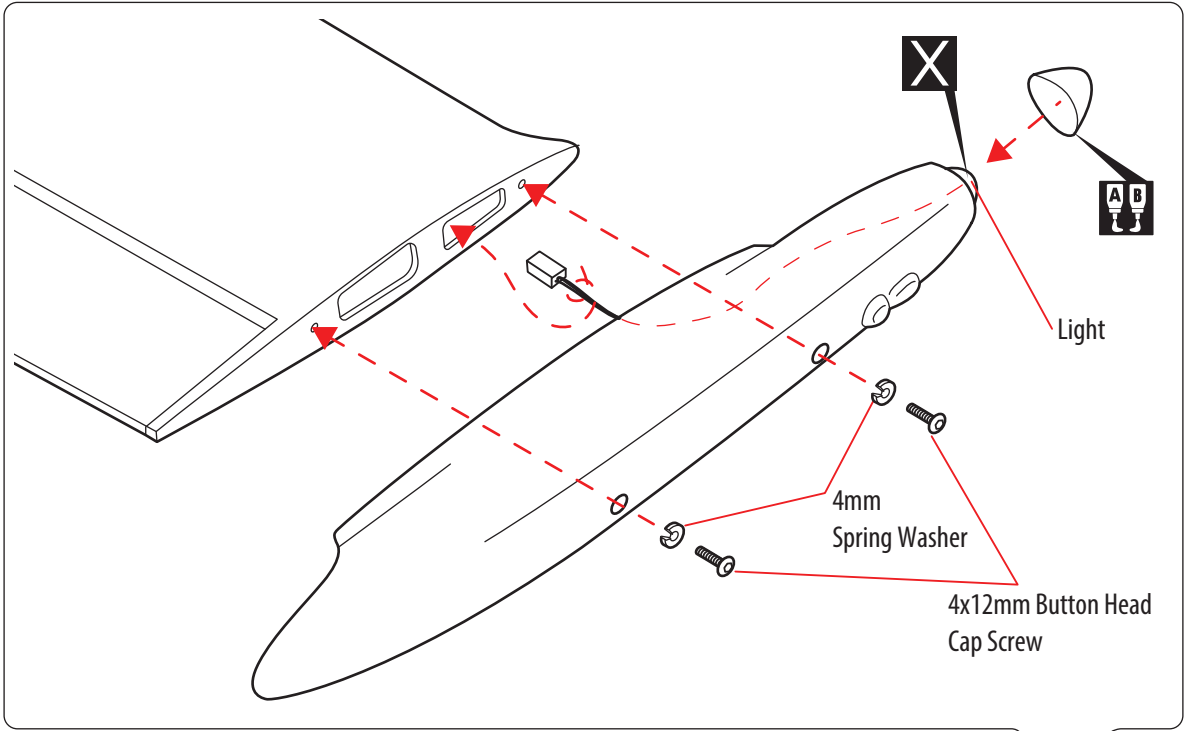

X Must be purchased separately!

 Cut off shaded portion carefully.

INSTALLING THE MAIN LANDING GEAR

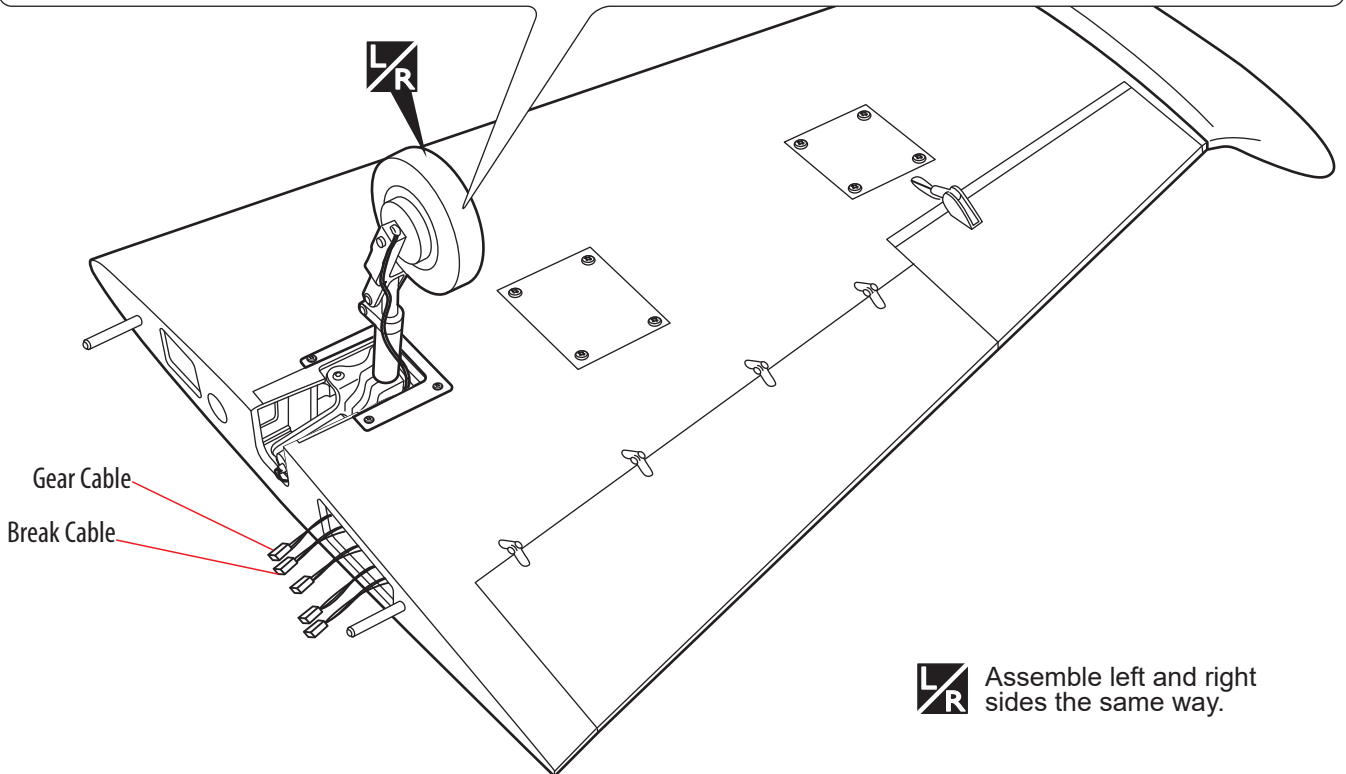
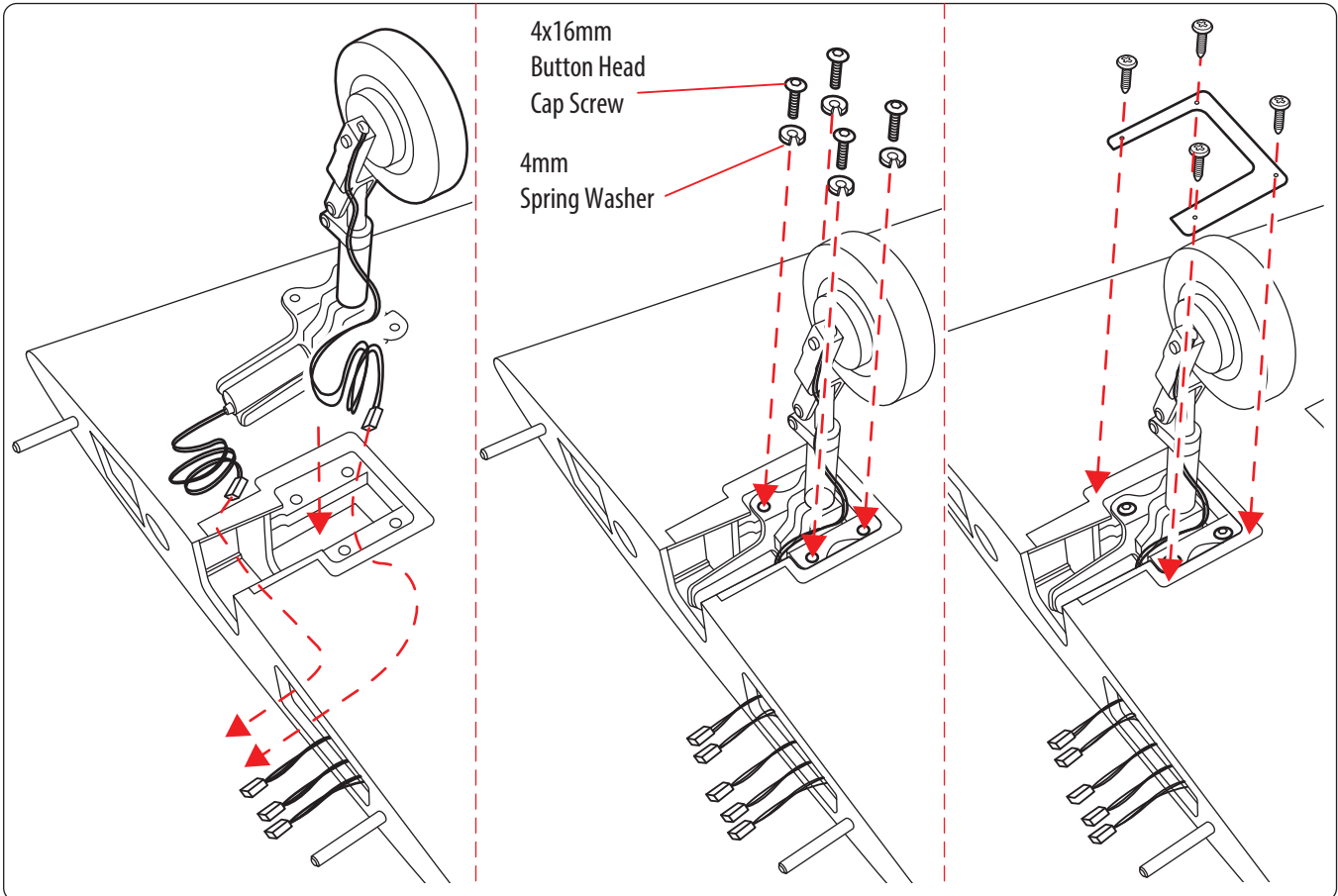
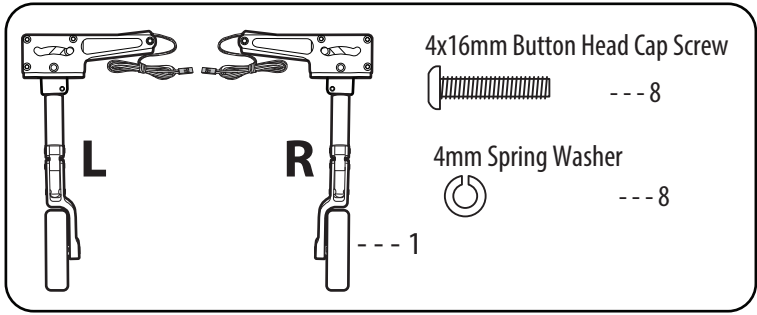

LR Assemble left and right sides the same way.



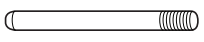

INSTALLING THE HORIZONTAL STABILIZER

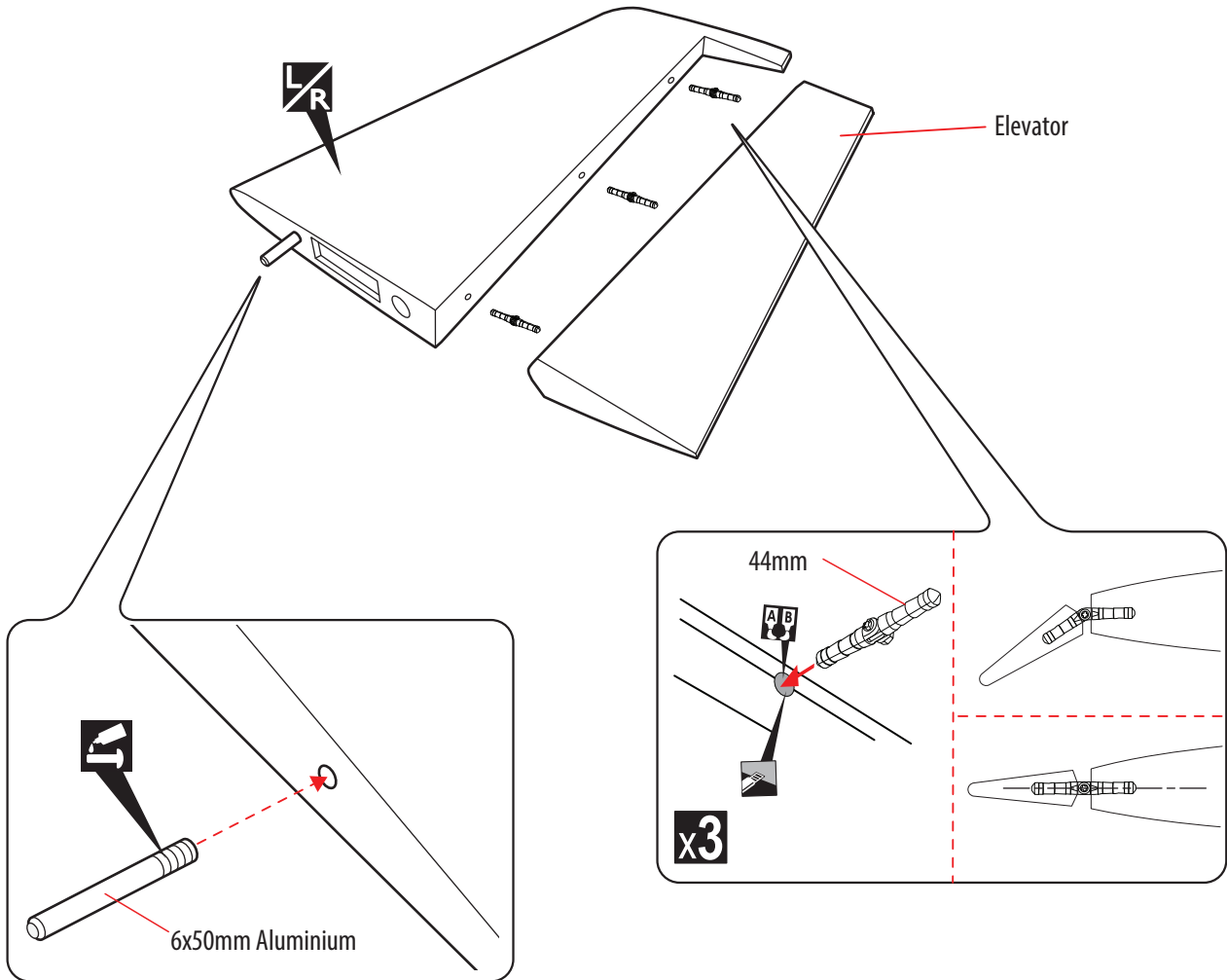
 44mm Pinned Hinge Aileron --- 6	 6x50mm Aluminium --- 2
---	--

Bottom view

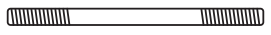

INSTALLING THE HORIZONTAL STABILIZER SERVO

 Horn --- 2	 2.6x50mm Pushrod Elevator --- 2	 3x12mm Button Head Cap Screw --- 4
 Ball Link --- 4	 3mm Flat Washer --- 4	 3mm Lock Nut --- 4

 Cut off shaded portion carefully.

 Apply threadlocker (screw cement).

 Apply epoxy glue.

x2 The number of times the same way Assembly (in this case twice).

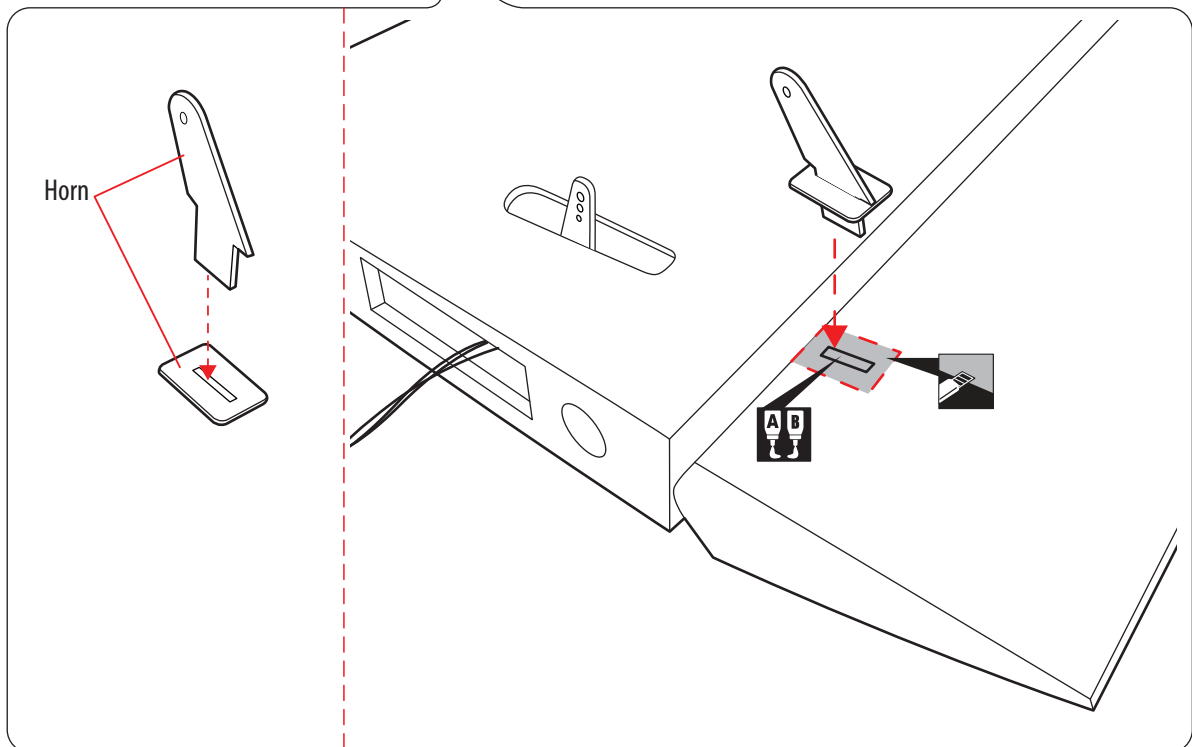
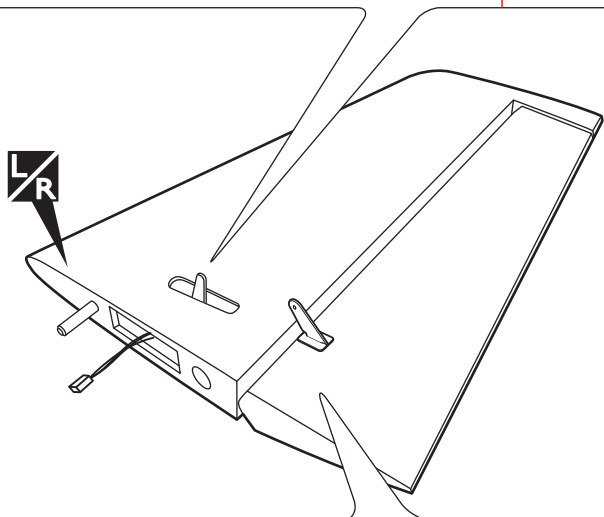
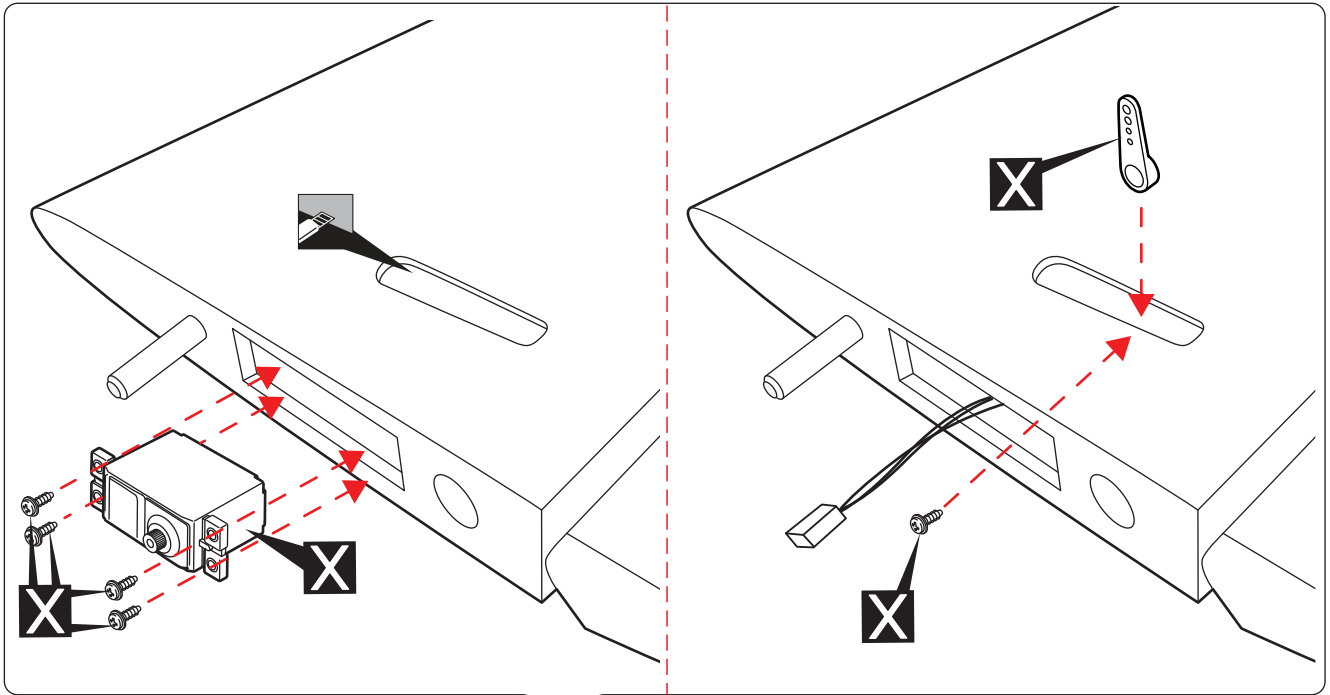

X Must be purchased separately!

L/R Assemble left and right sides the same way.

A B Apply epoxy glue.

X Cut off shaded portion carefully.

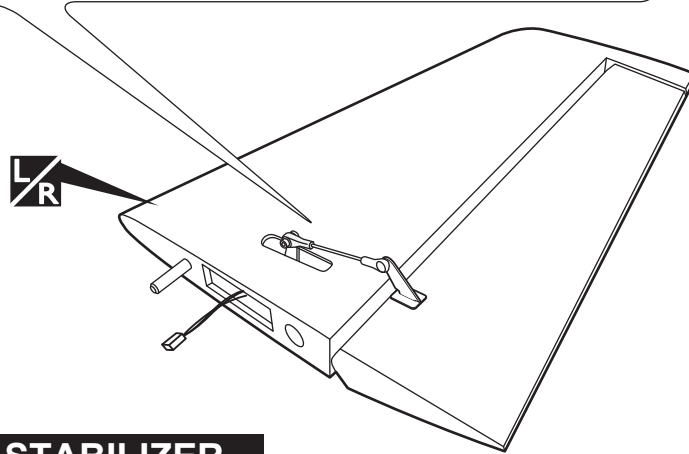
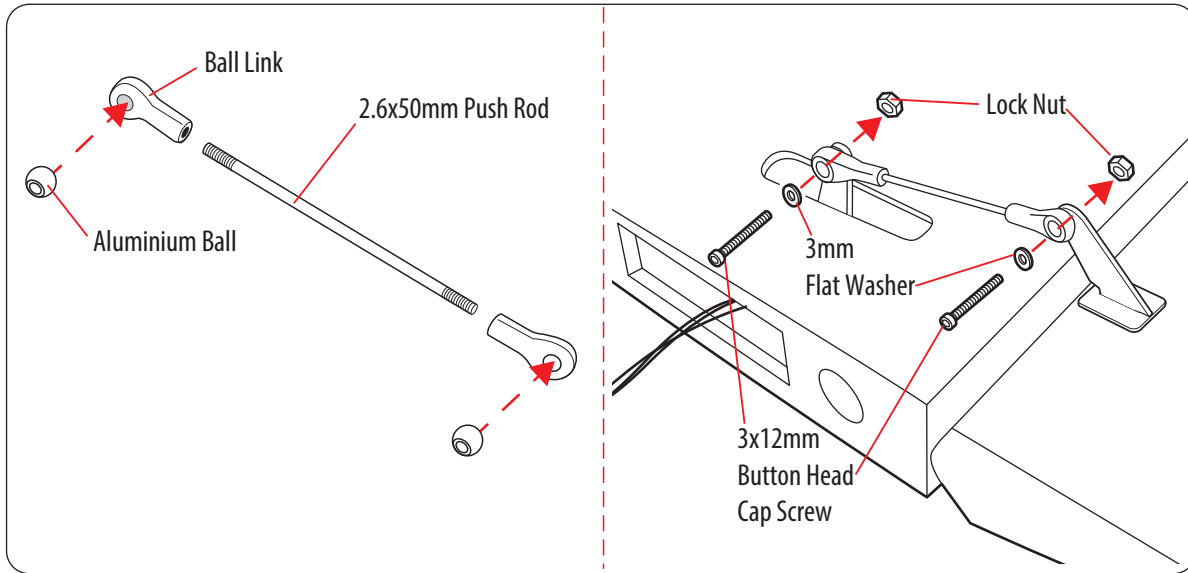





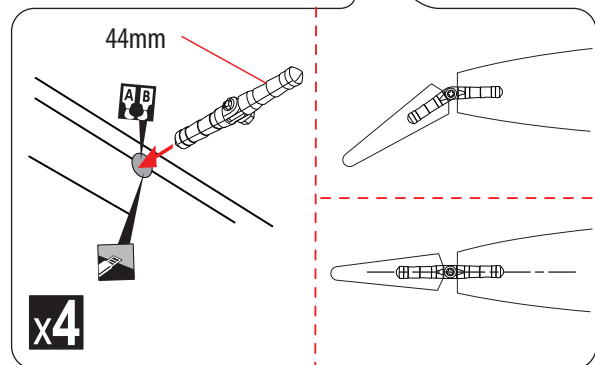
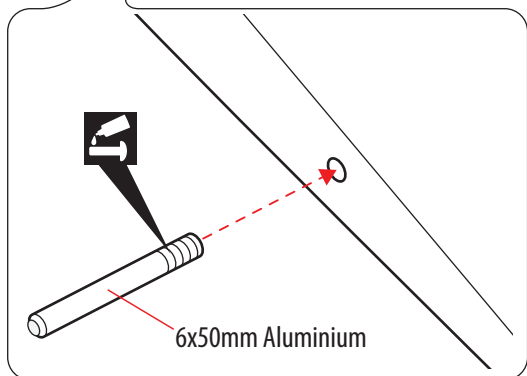
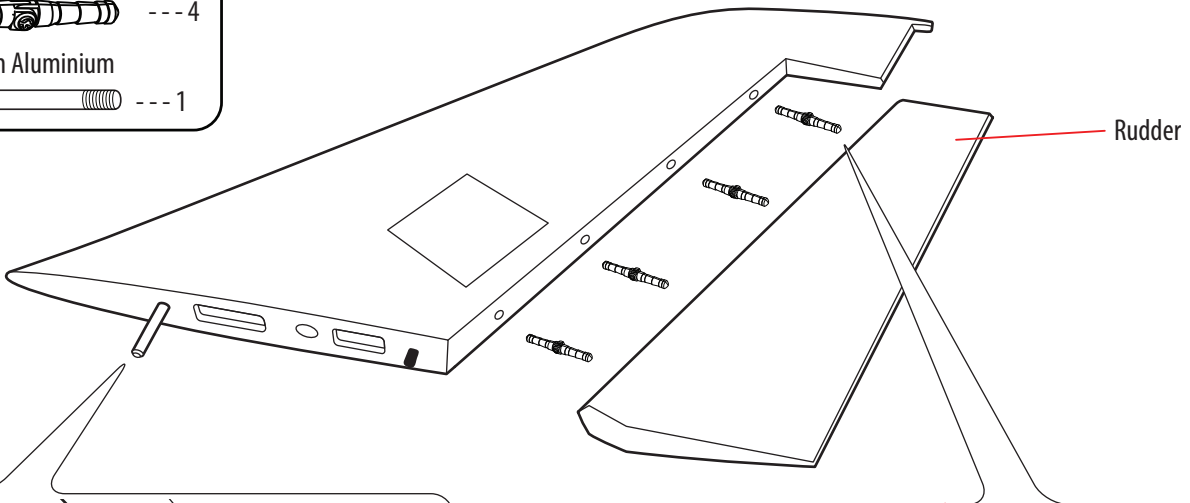



INSTALLING THE VERTICAL STABILIZER

- 44mm Pinned Hinge Aileron --- 4
- 6x50mm Aluminium --- 1





INSTALLING THE VERTICAL STABILIZER SERVO

 Horn ---1	 2.6x45mm Pushrod Elevator ---1	 3x12mm Button Head Cap Screw ---2
 Ball Link ---1	 ---2	 3mm Flat Washer ---2
 ---2	 2x10mm Tp Screw ---4	 3mm Lock Nut ---2

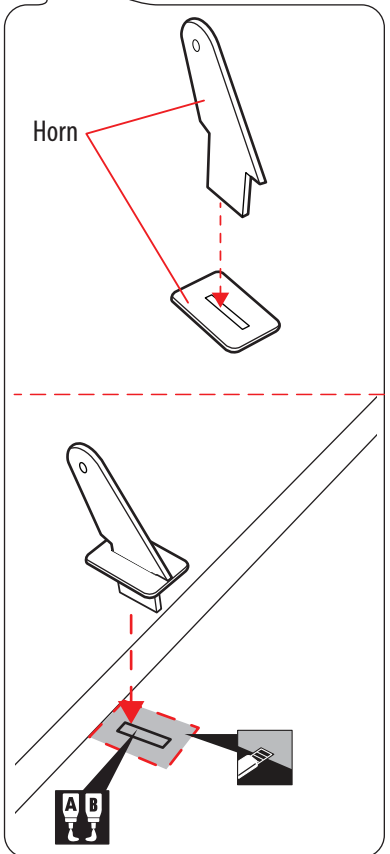
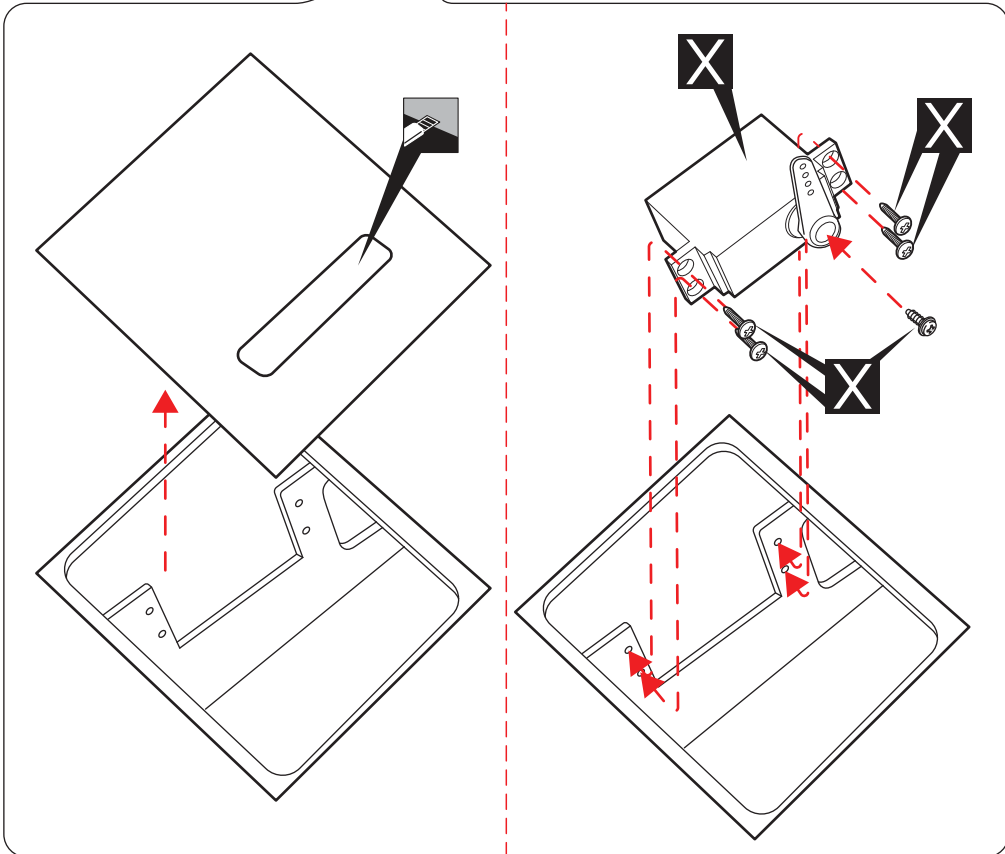
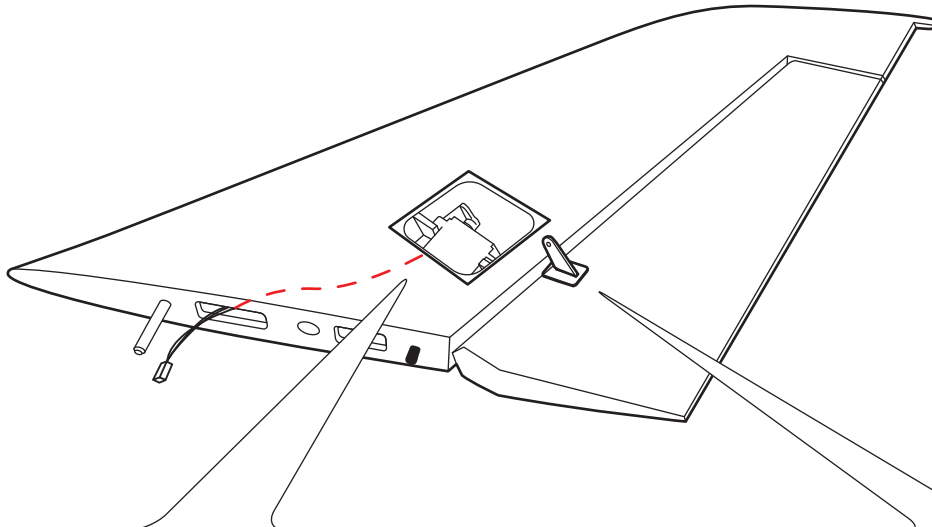
Left view



 Must be purchased separately!

 Apply epoxy glue.

Left view

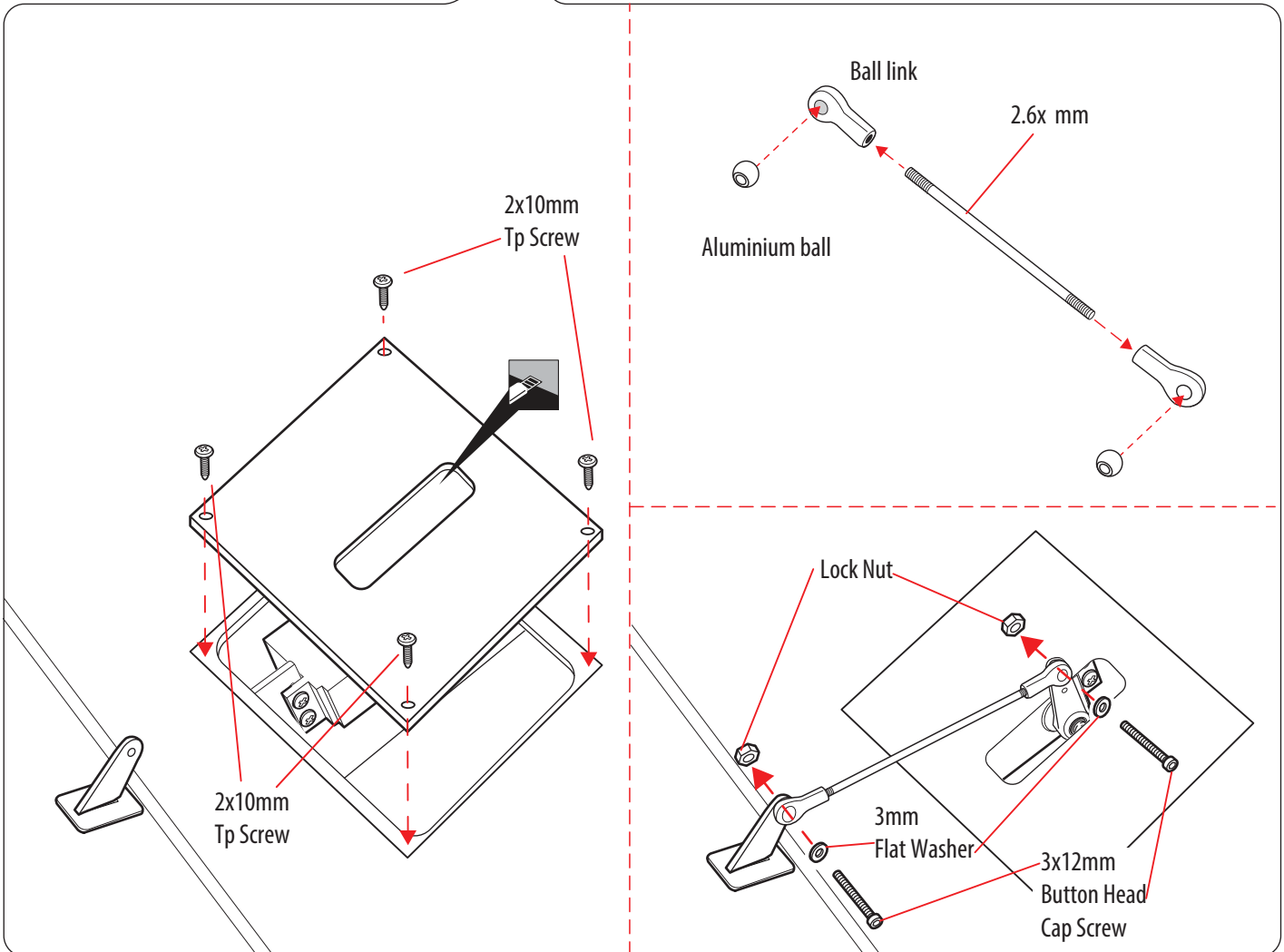
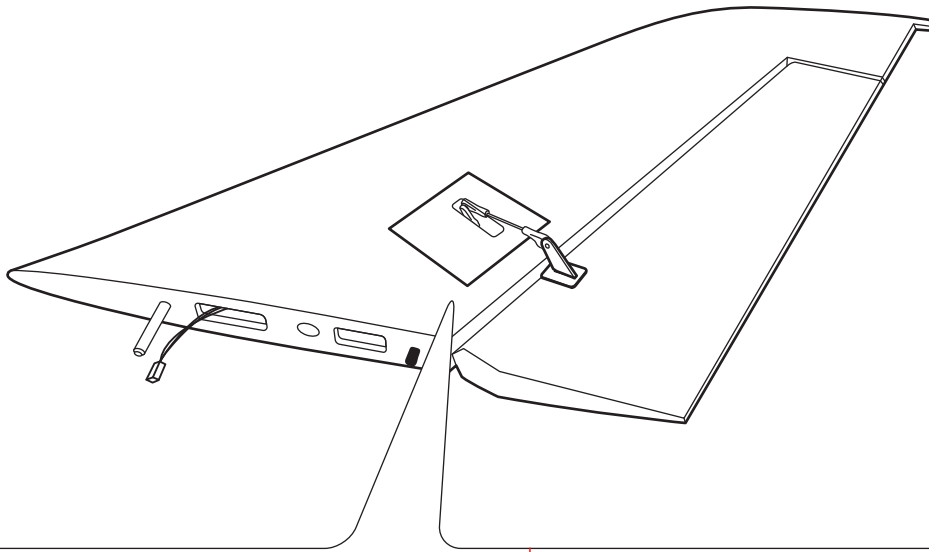

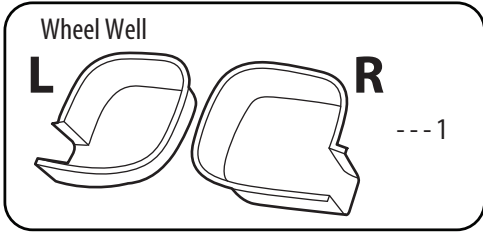

 Cut off shaded portion carefully.

INSTALLING THE WHEEL WELL

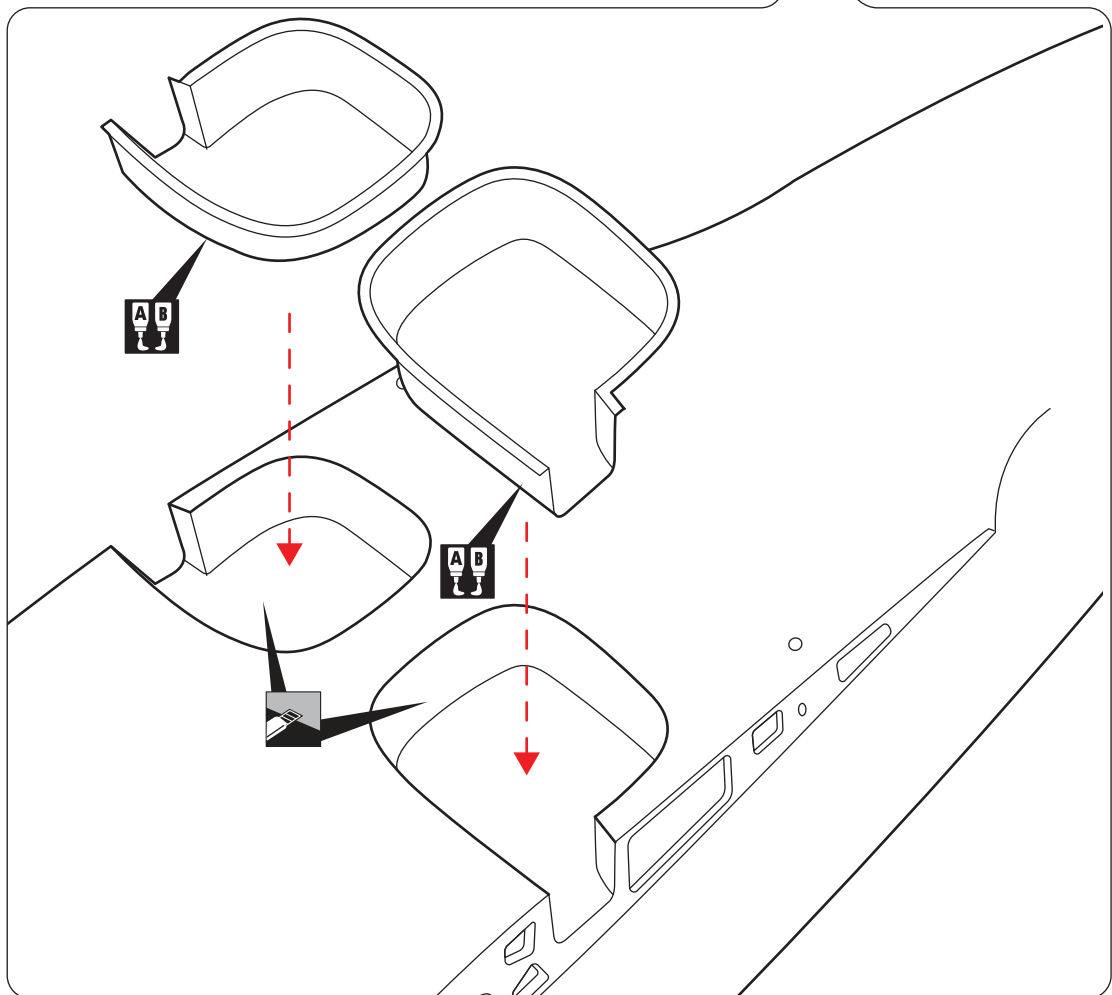
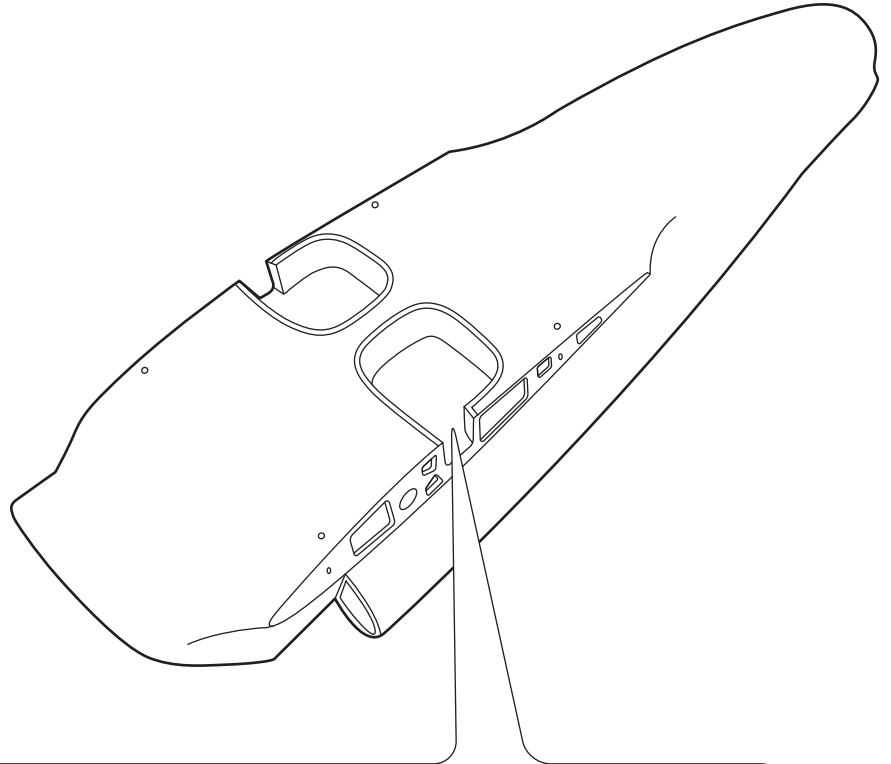

Bottom view



 Cut off shaded portion carefully.

 Apply epoxy glue.

INSTALLING THE FUSELAGE

Ø12x198mm Aluminium Tube --- 3
 4x16mm Button Head Cap Screw --- 4
 4mm Aluminium Washer --- 4

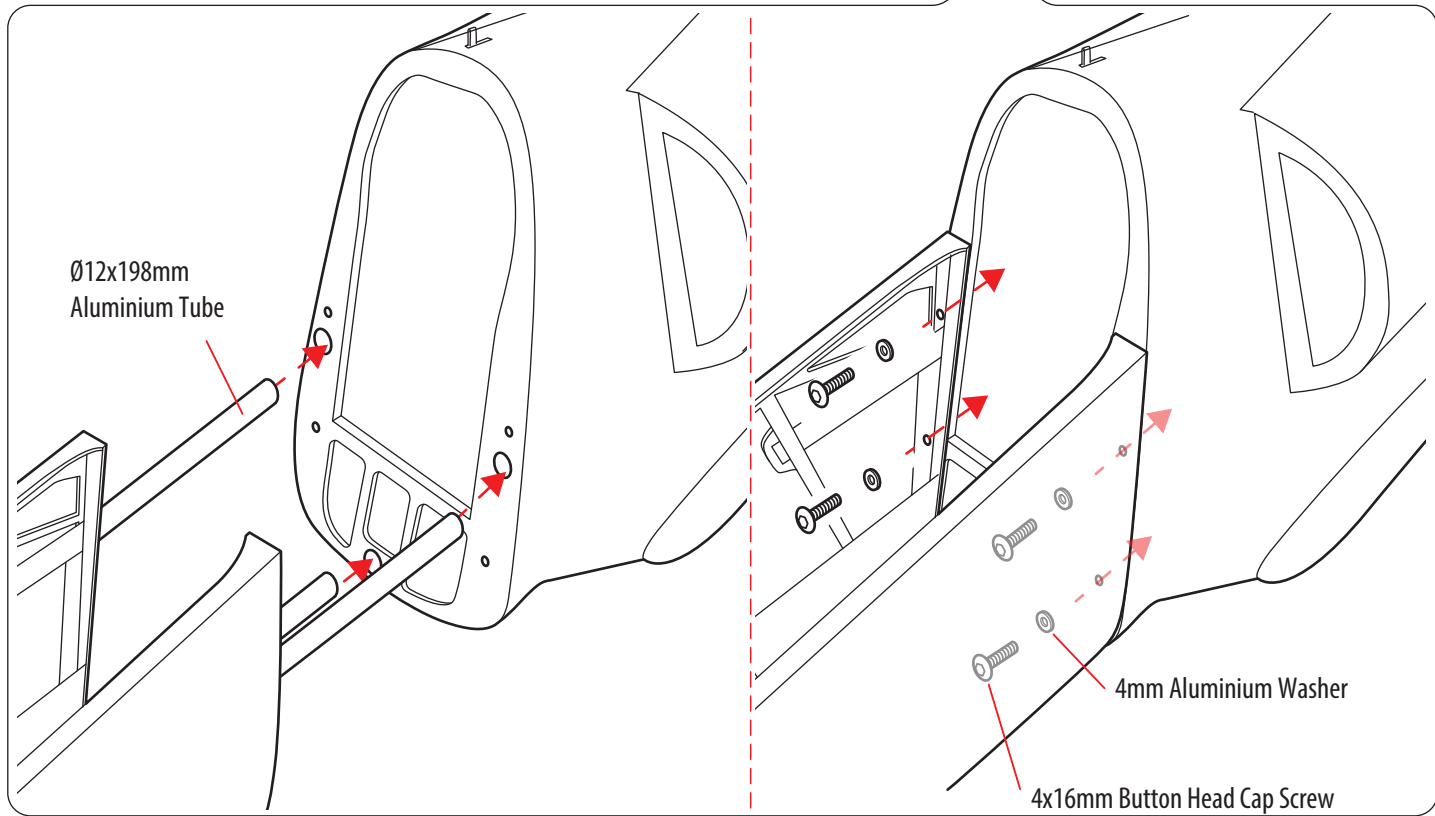
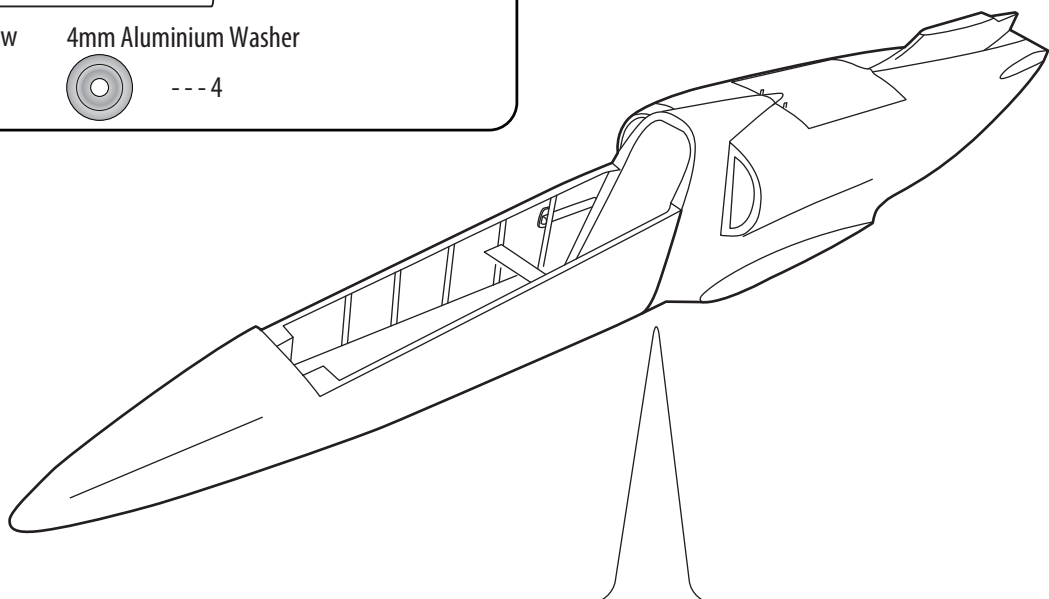

INSTALLING THE AIR INTAKE

Air Intake

L **R** --- 1

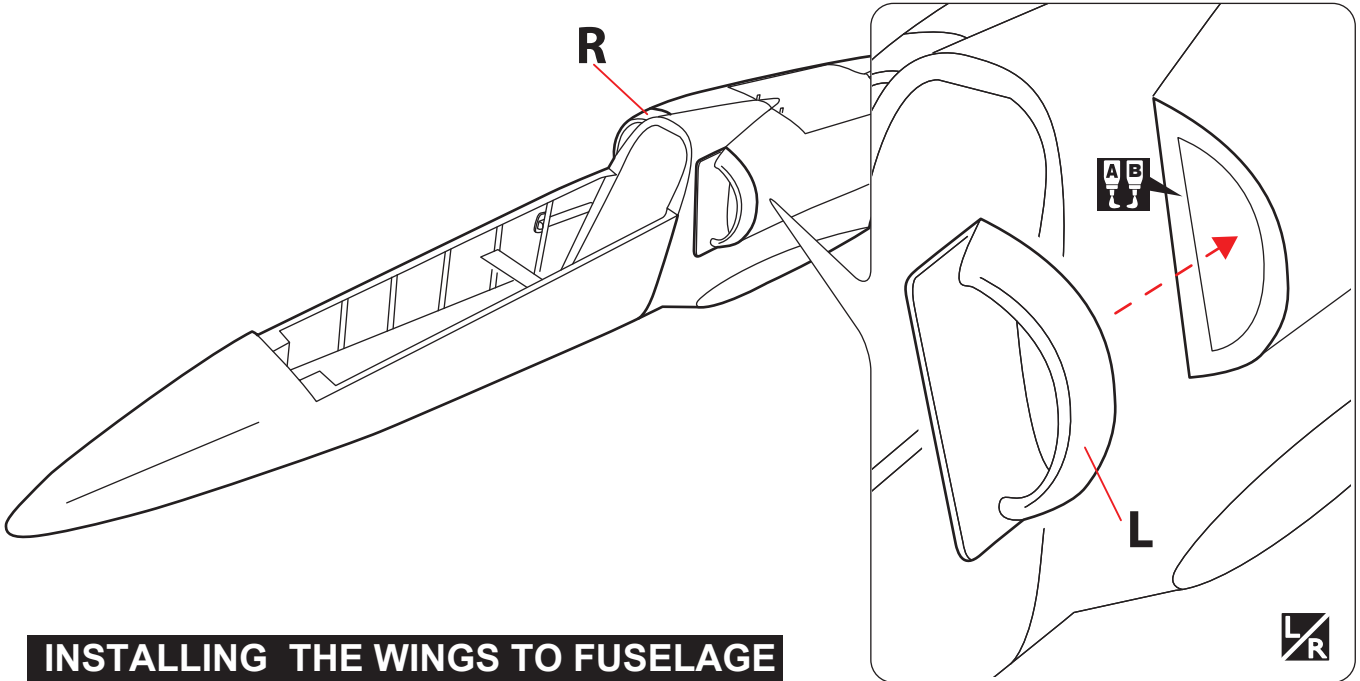



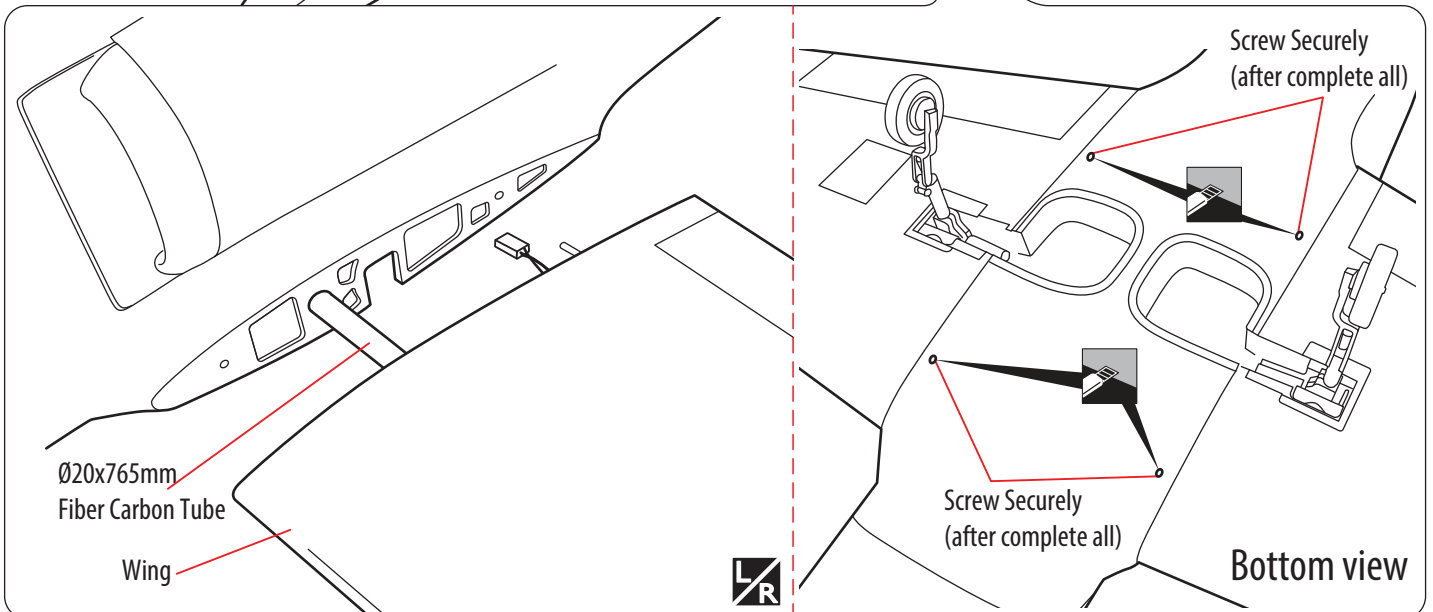
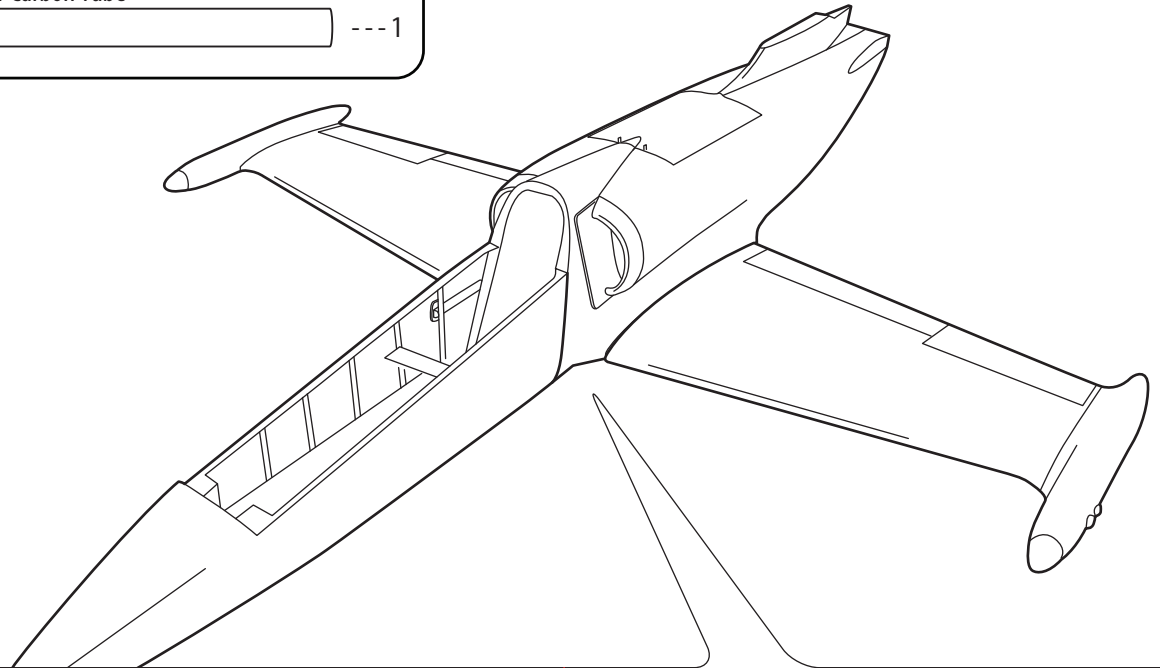
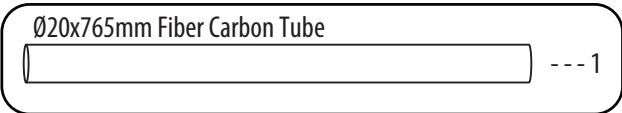



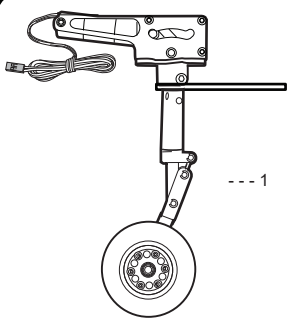

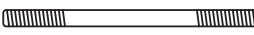
INSTALLING THE WINGS TO FUSELAGE



INSTALLING THE NOSE GEAR RETRACT

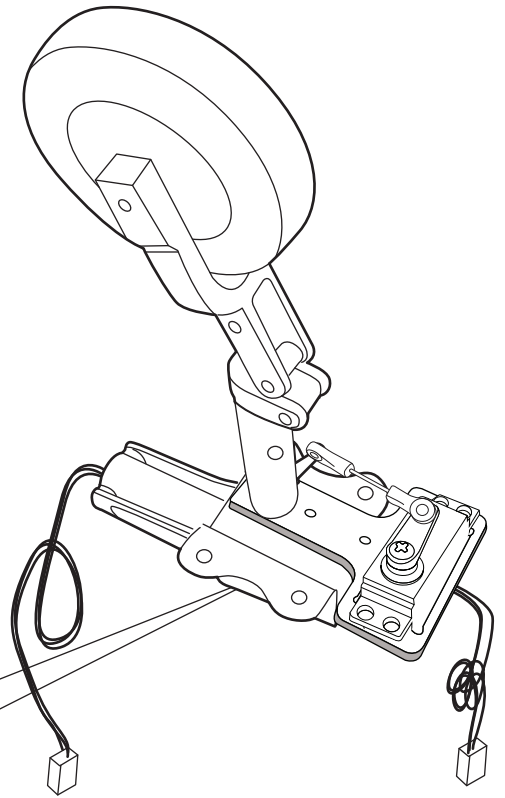
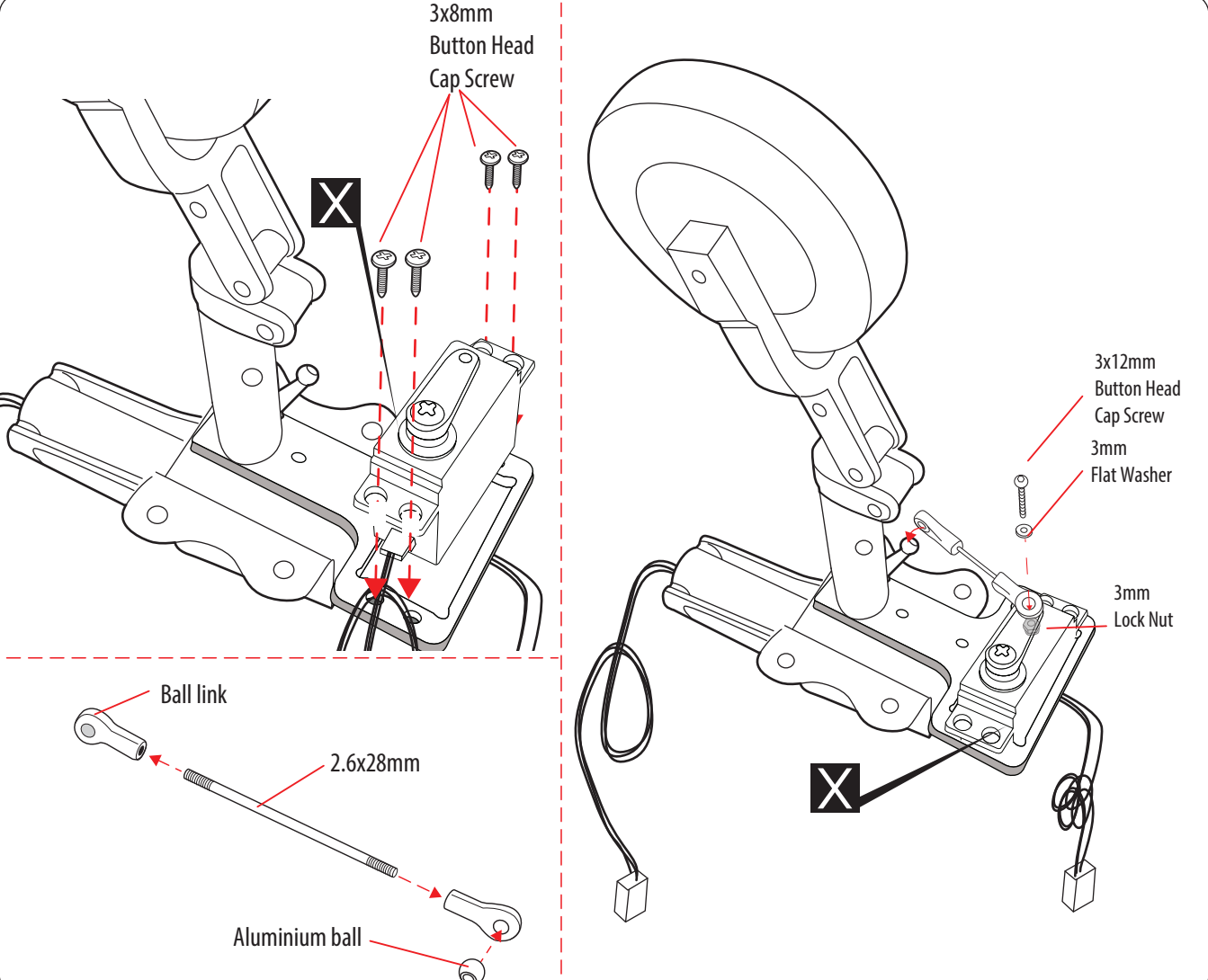

2.6x28mm Pushrod 	--- 1	3x12mm Button Head Cap Screw 	--- 1
Ball Link 	--- 2	3mm Flat Washer 	--- 1
	--- 1	3mm Lock Nut 	--- 1
4x16mm Button Head Cap Screw 	--- 4	3x8mm Button Head Cap Screw 	--- 4
4mm Spring Washer 	--- 4		

3x8mm Button Head Cap Screw

Ball link

2.6x28mm

Aluminium ball

3x12mm Button Head Cap Screw

3mm Flat Washer

3mm Lock Nut

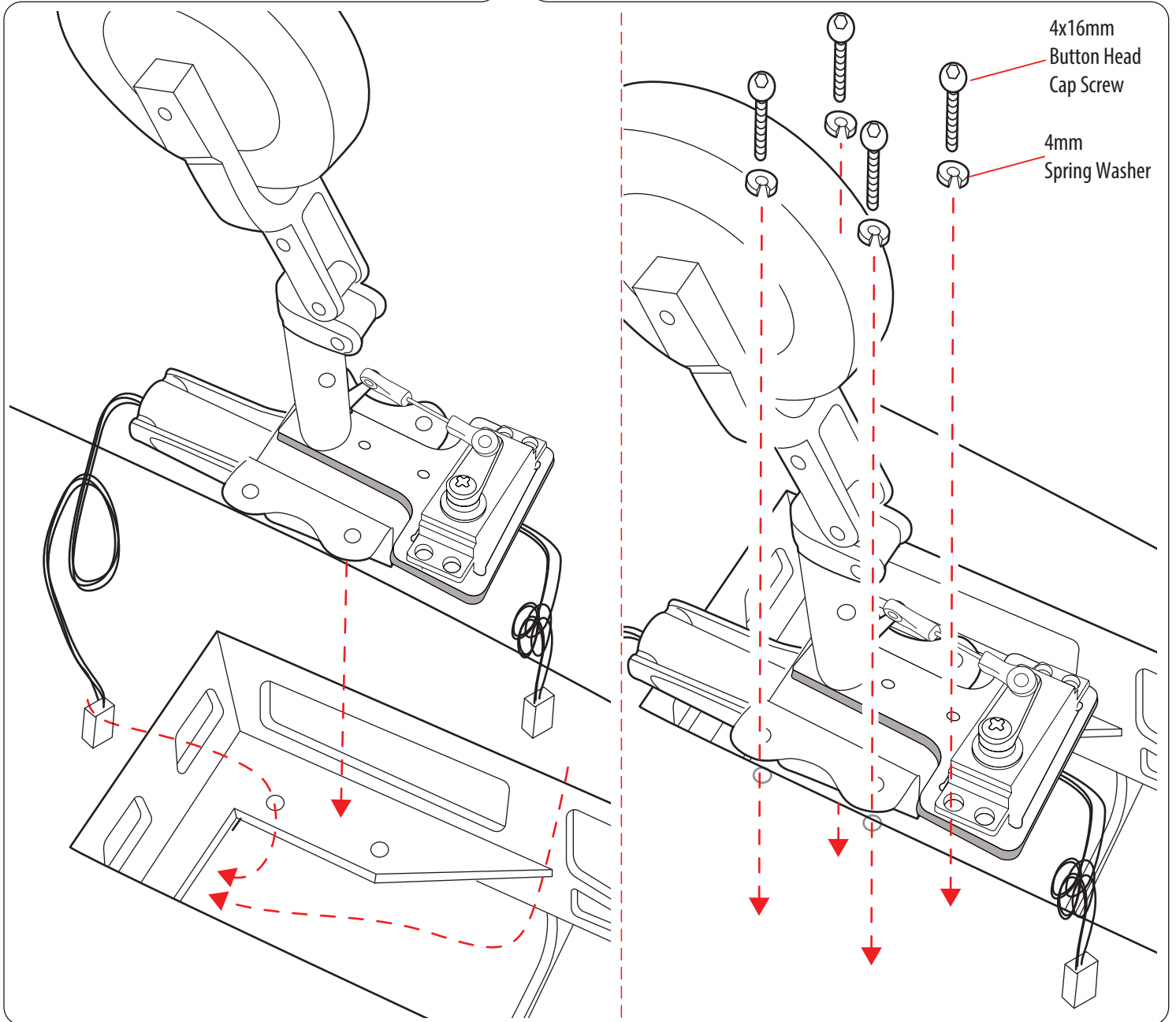
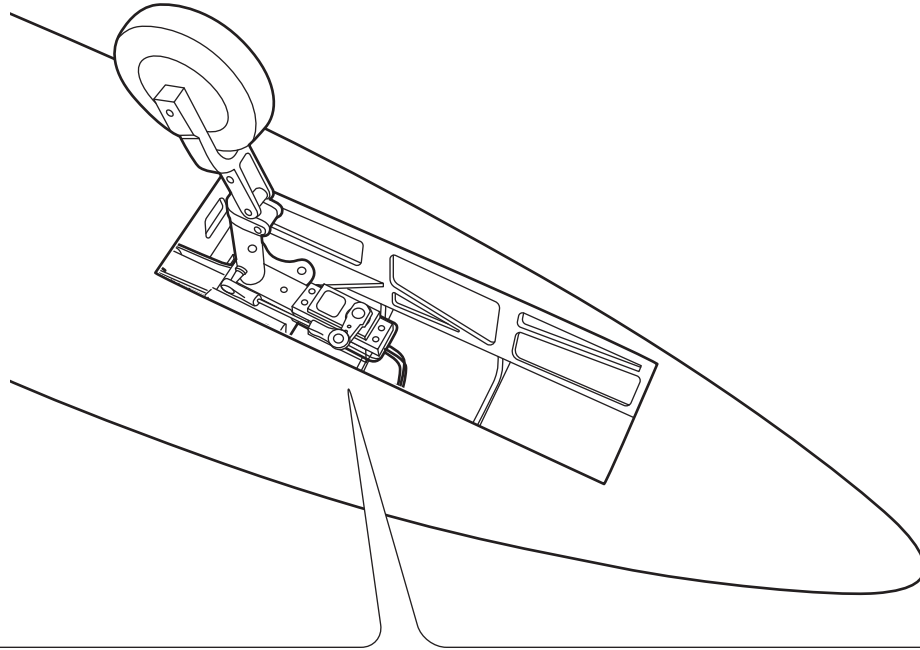

INSTALLING THE HORIZONTAL STABILIZER TO FUSELAGE

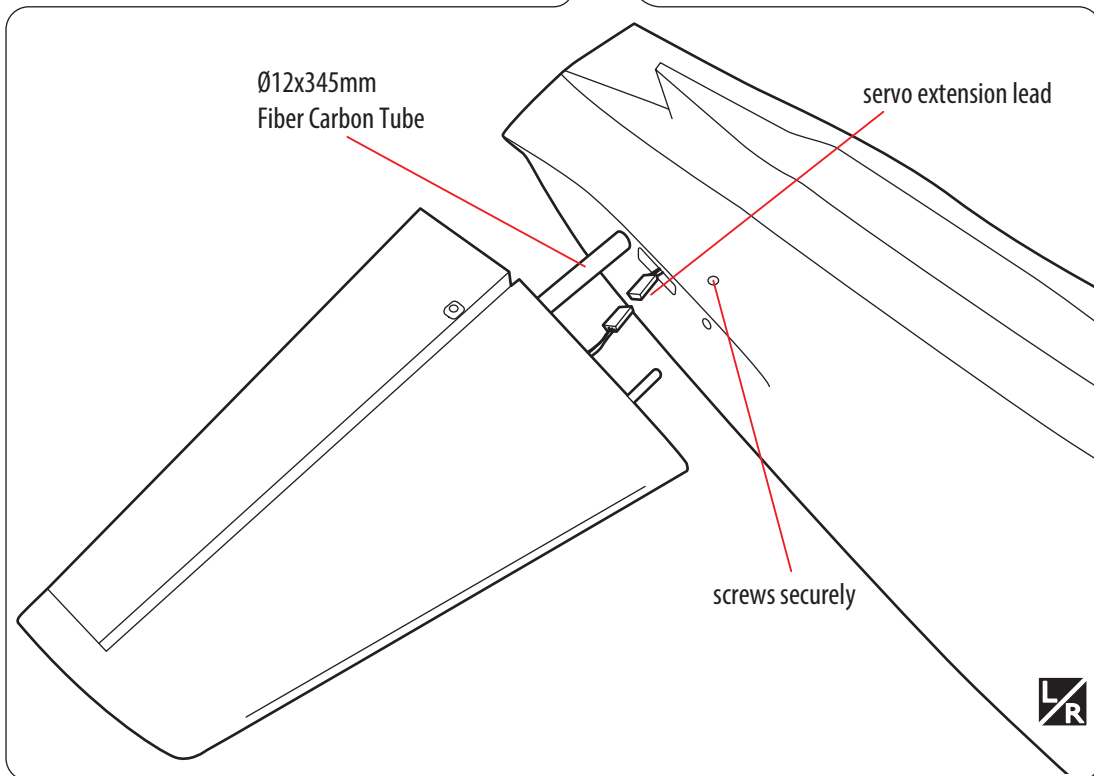
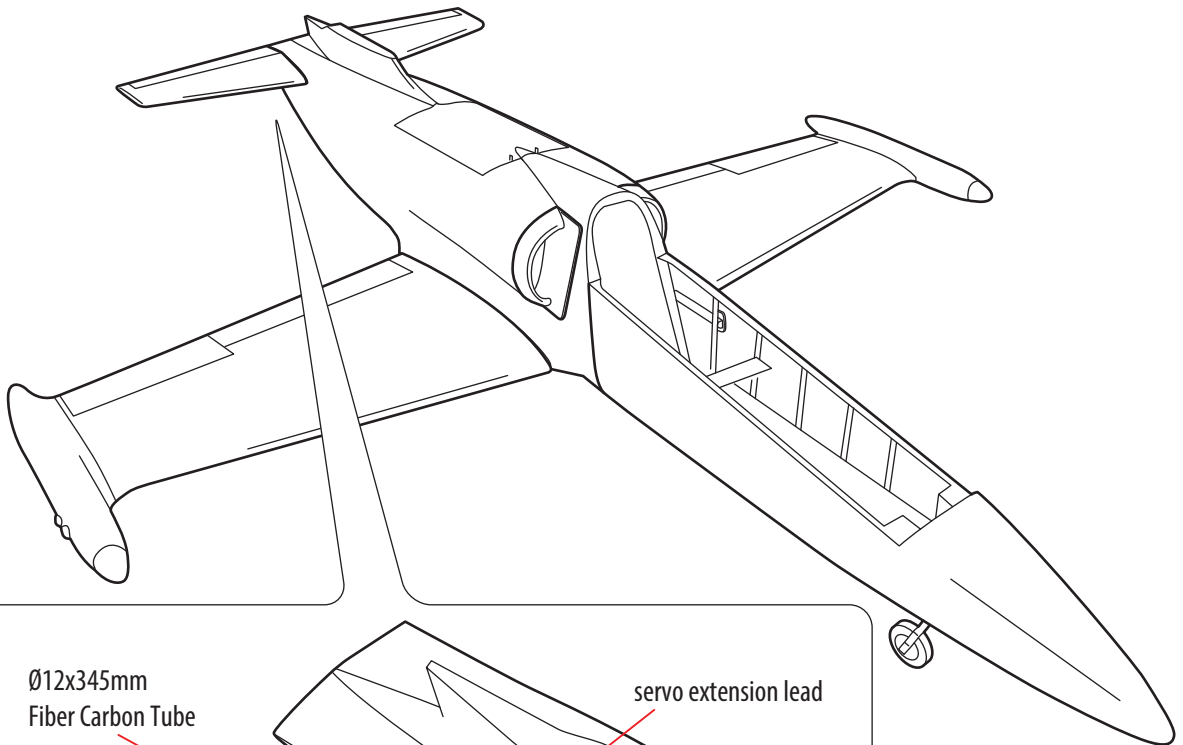
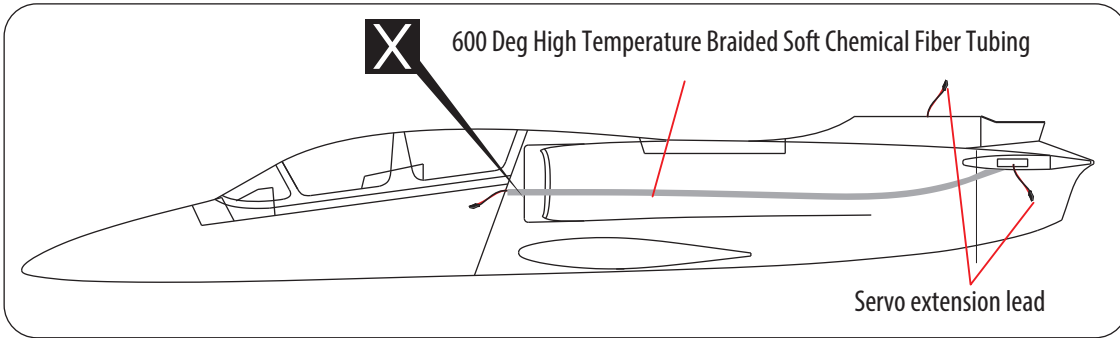
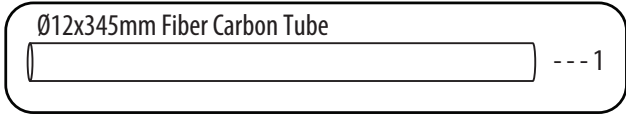

INSTALLING THE VERTICAL STABILIZER TO FUSELAGE

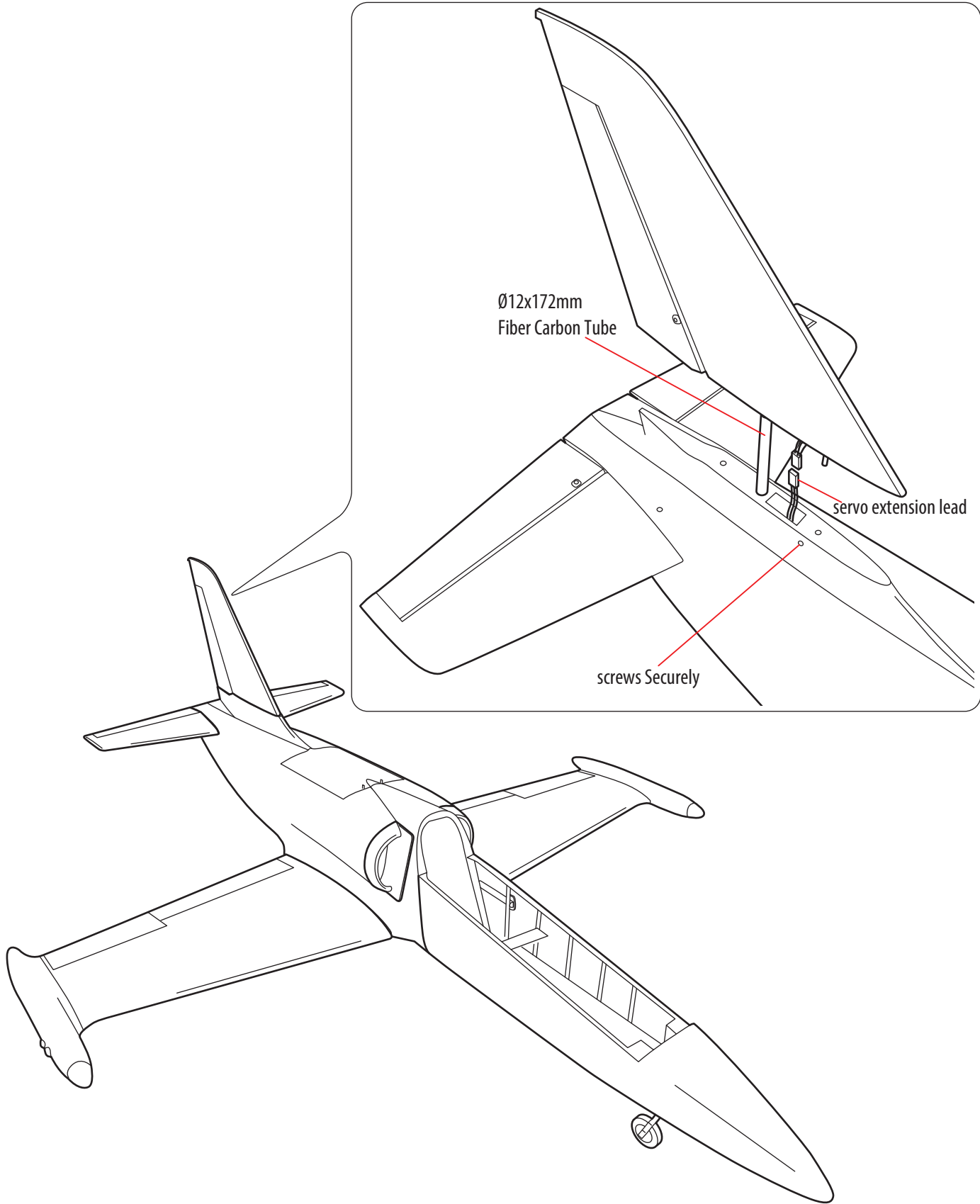
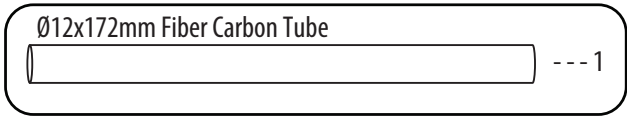



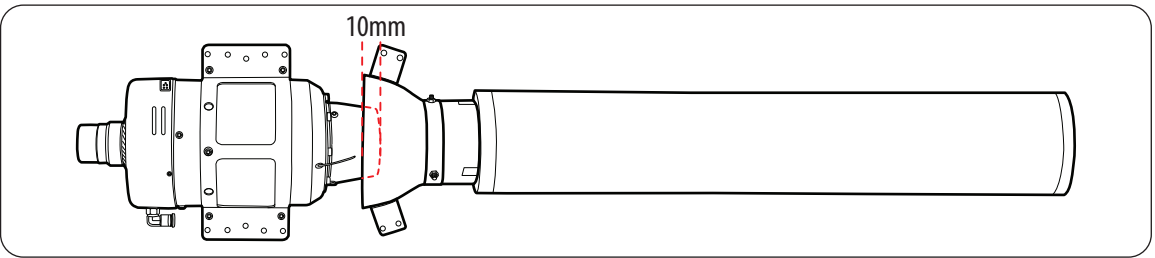
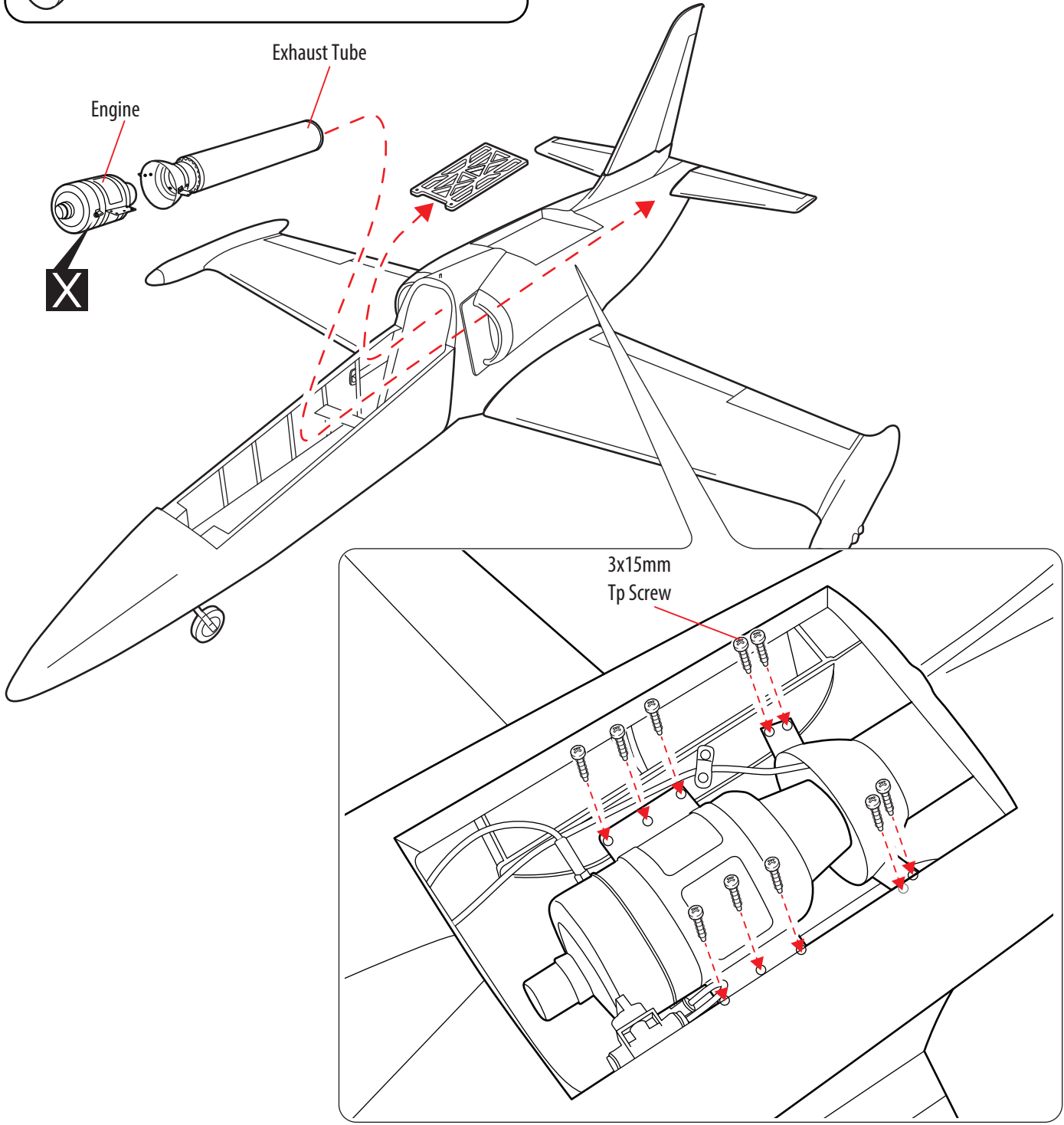
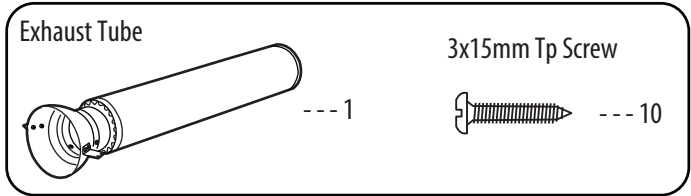



INSTALLING THE ENGINE

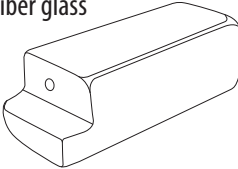

X Must be purchased separately!

INSTALLING THE FUEL TANK

<p>Clunks ---1</p> 	<p>3x25mm Screw ---1</p> 	<p>87mm Copper tube ---1</p> 	<p>Fiber glass ---1</p> 
<p>Rubber ---1</p> 	<p>Aluminium ---1</p> 	<p>55mm Copper tube ---2</p> 	
	<p>Aluminium ---1</p> 		

INSTALLING THE STOPPER

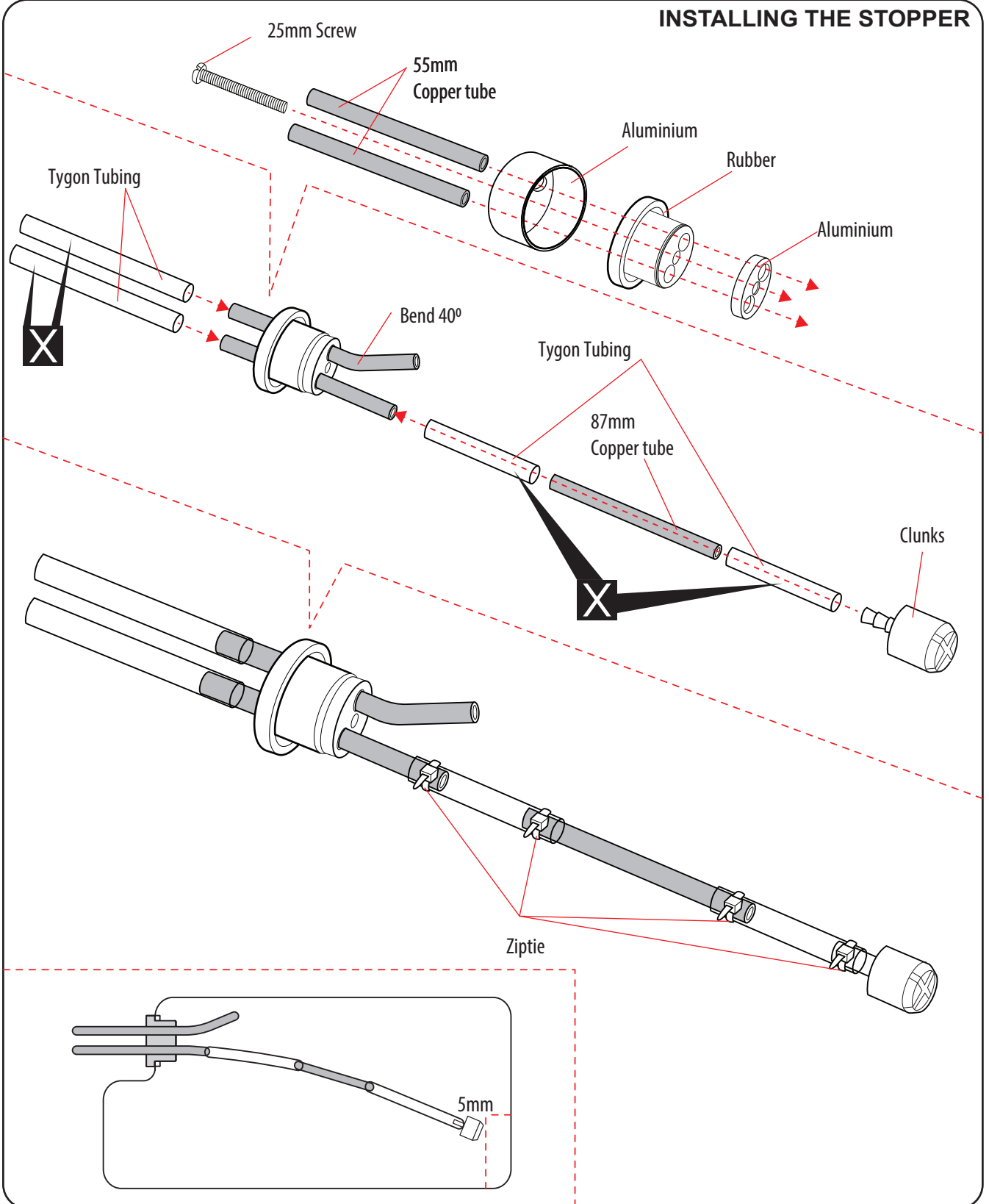

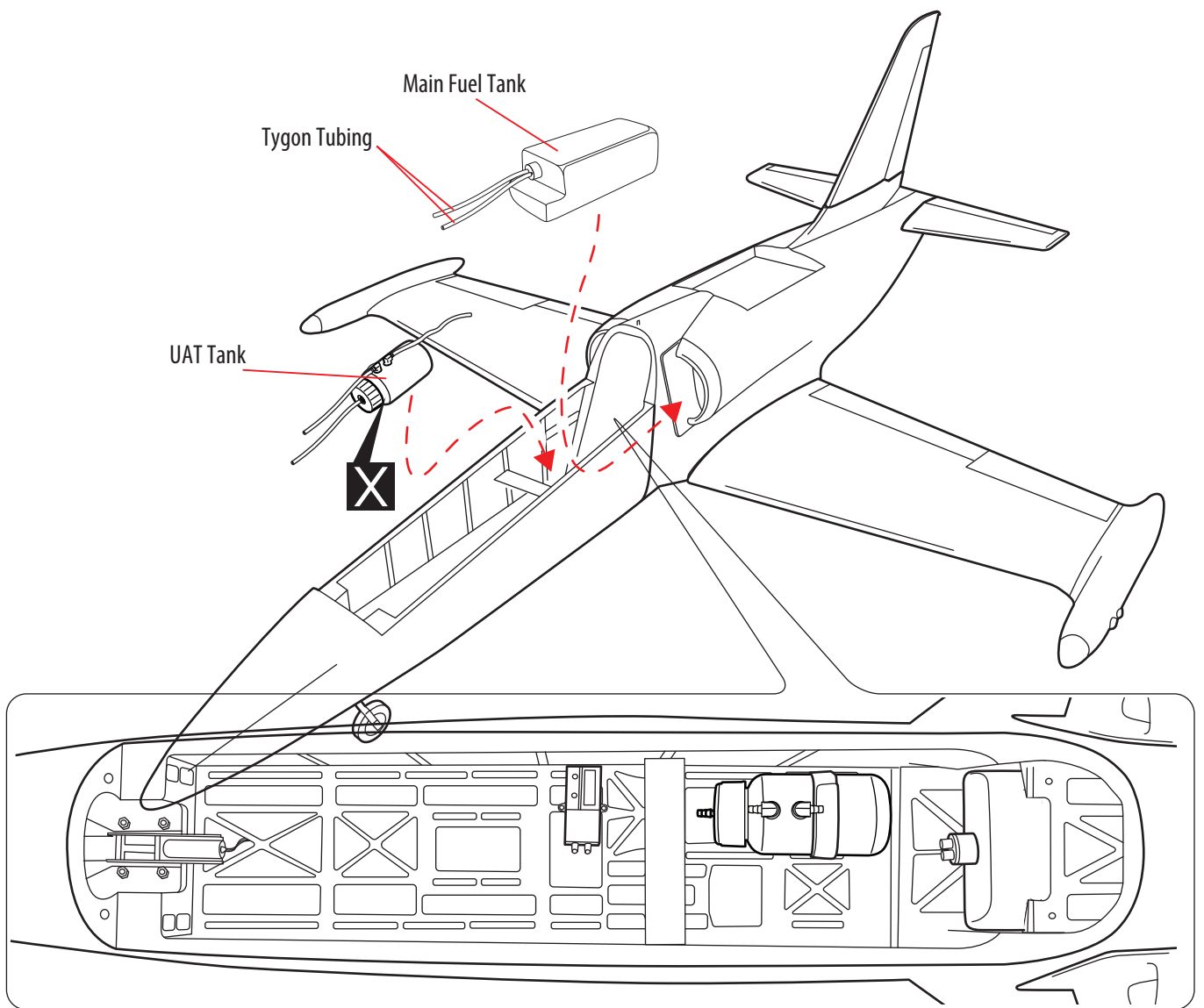

FUEL SYSTEM

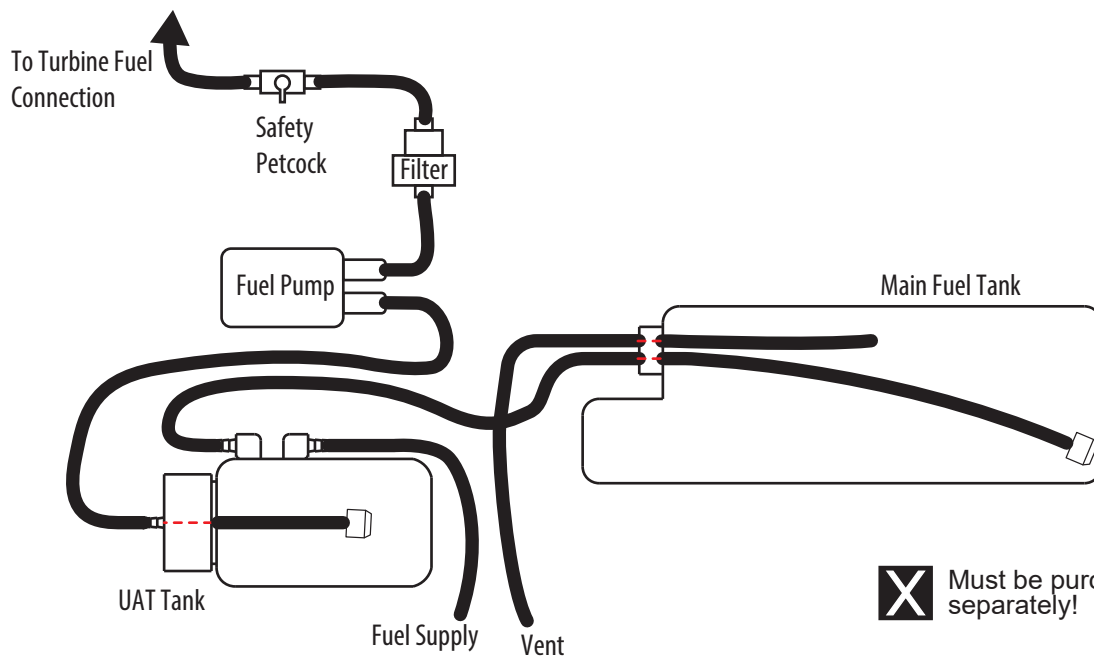

X Must be purchased separately!

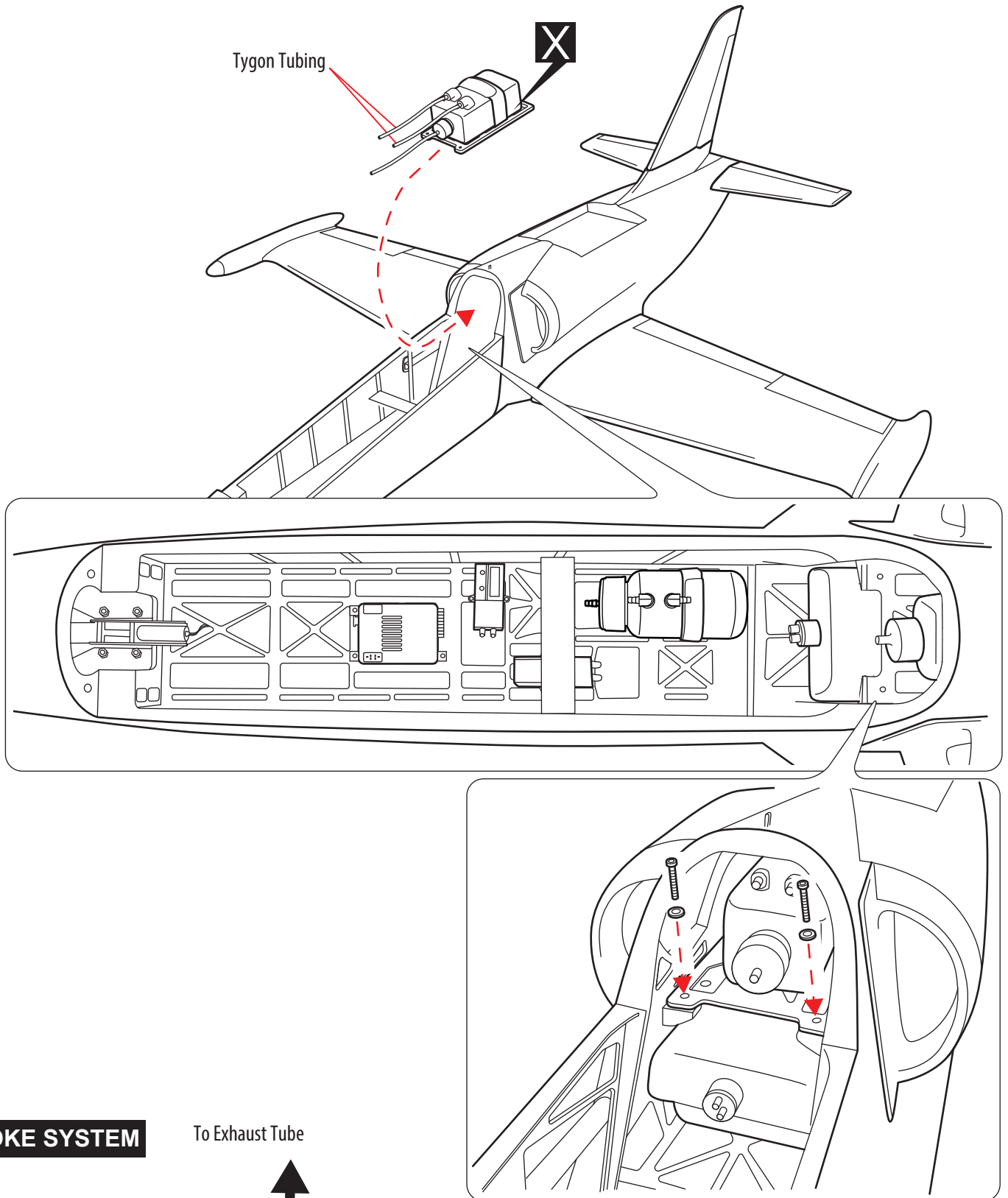

SMOKE SYSTEM

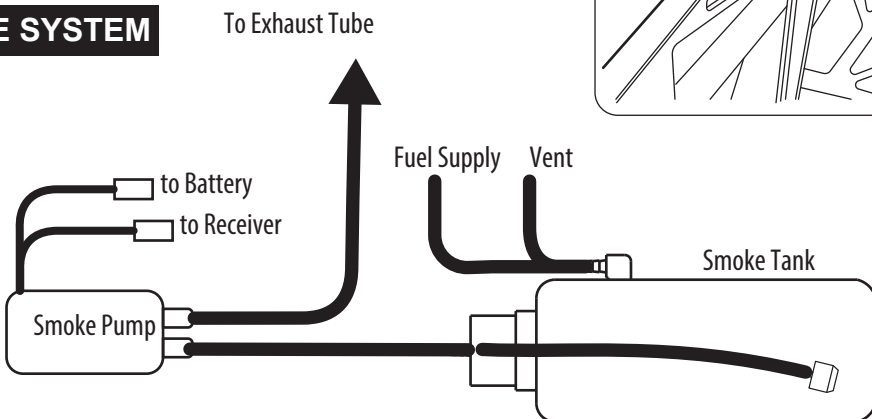

INSTALLING THE RECEIVER, BATTERY, CONTROLLER BOX AND SWITCH

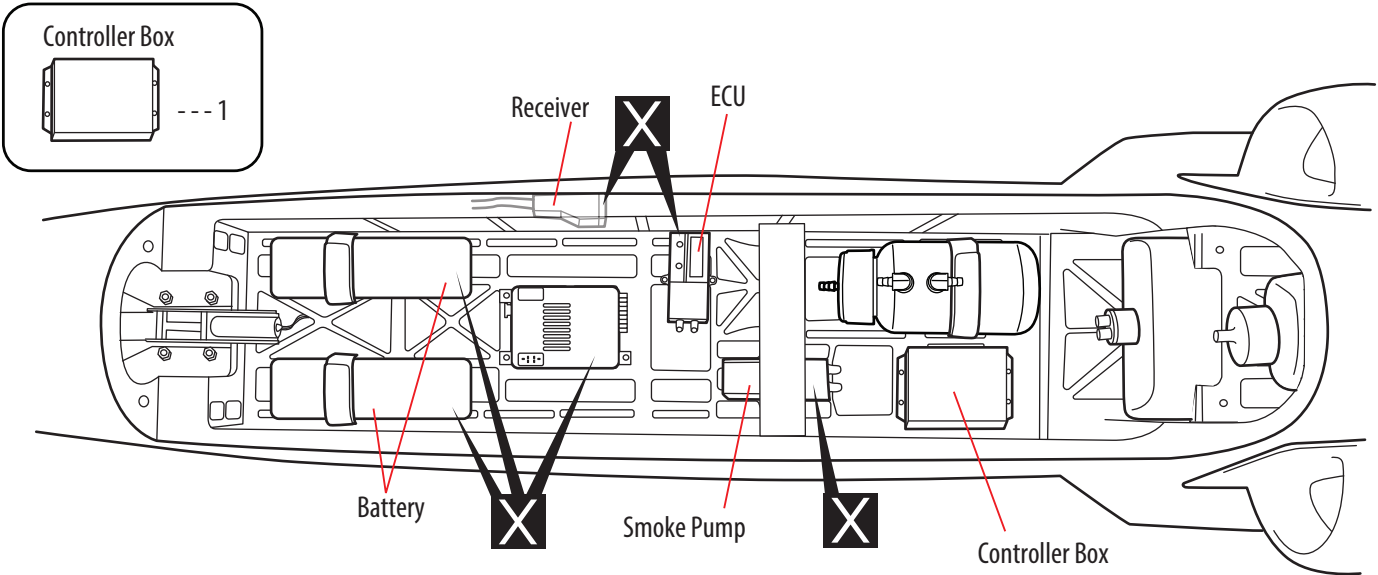

INSTALLING THE COCKPIT FUSELAGE

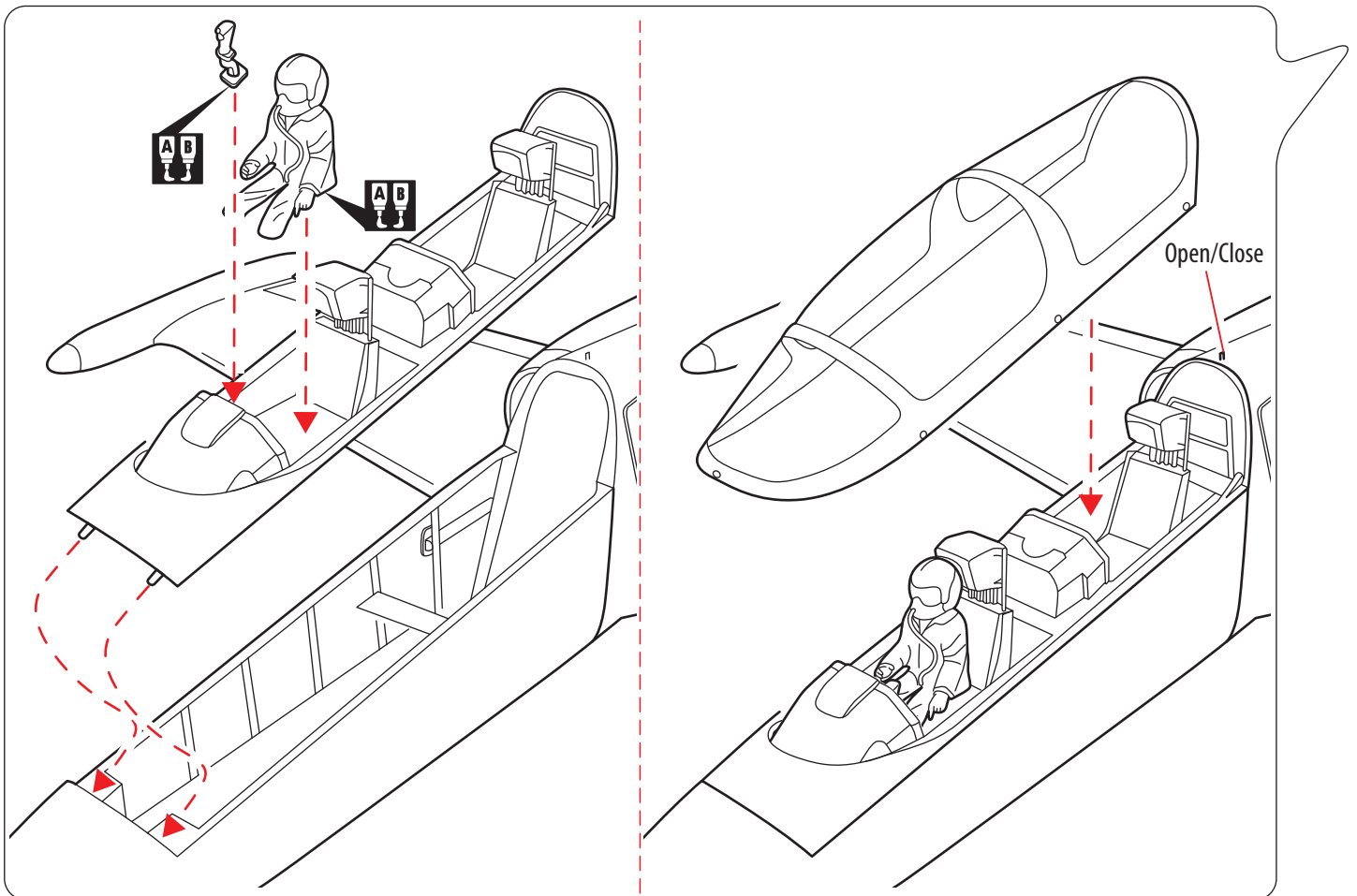
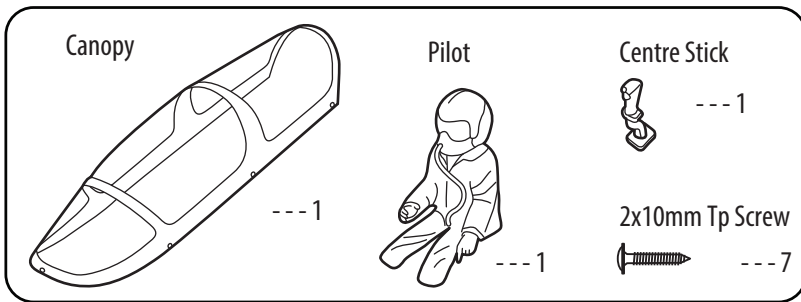

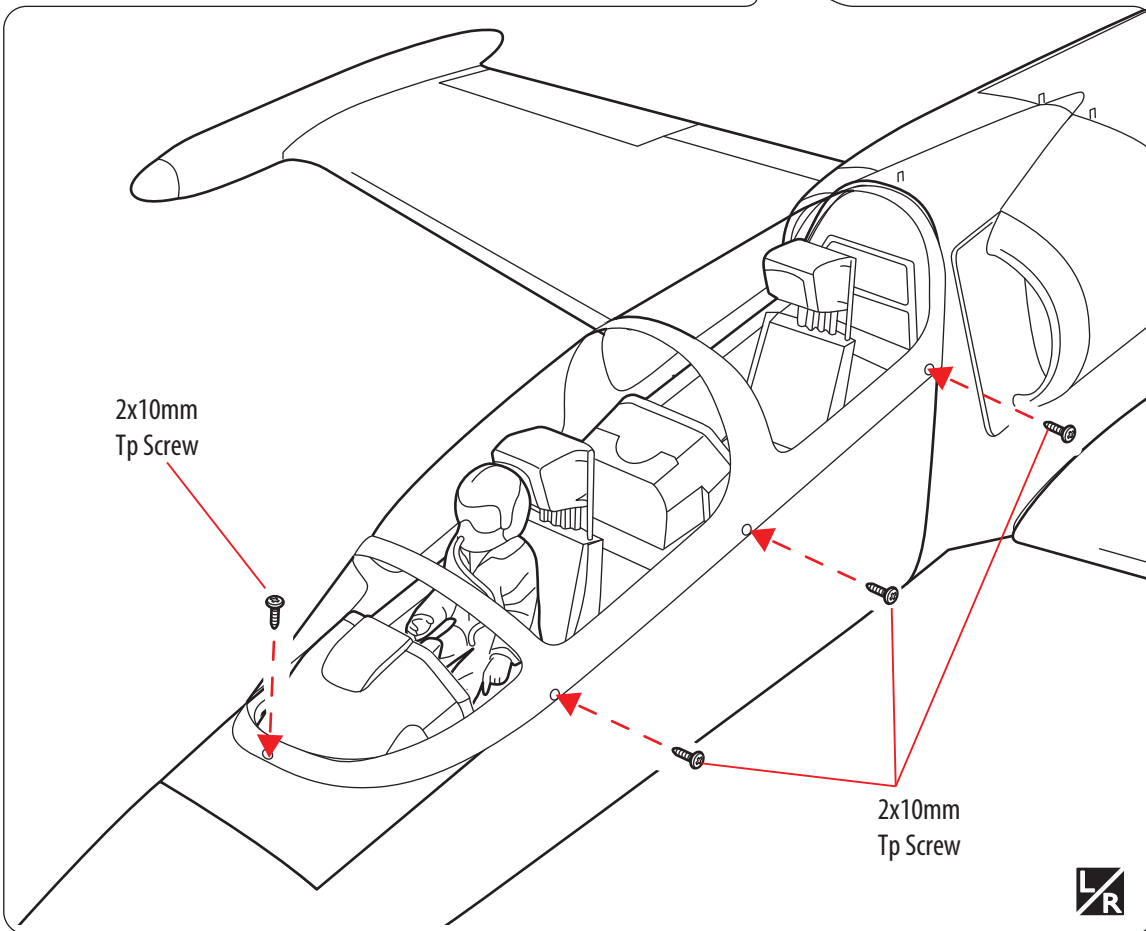
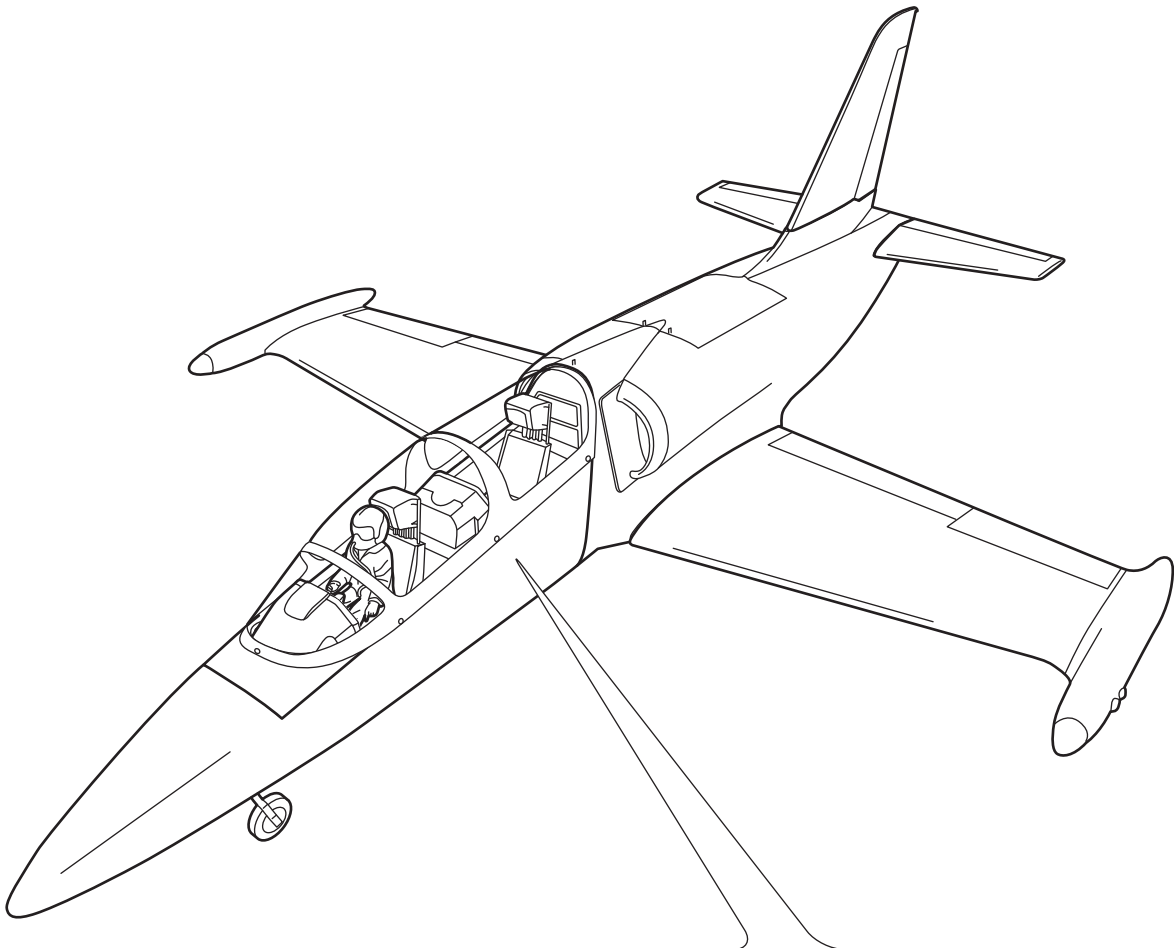

BALANCING

1. It is critical that your airplane be balanced correctly. Improper balance will cause your plane to lose control and crash.

THE CENTER OF GRAVITY IS LOCATED 124mm (4.88in) BACK FROM THE LEADING EDGE OF THE WING, AT THE FUSELAGE. BALANCE A PLANE UPSIDE DOWN WITH THE FUEL TANK EMPTY.

2. If the nose of the plane falls, the plane is nose heavy. To correct this first move the battery pack further back in the fuselage. If this is not possible or does not correct it, stick small amounts of lead weight on the fuselage under the horizontal stabilizer. If the tail of the plane falls, the plane is tail heavy. To correct this, move the battery and receiver forward or if this is not possible, stick weight into the firewall. When balanced correctly, the airplane should sit level or slightly nose down when you lift it up with your fingers.

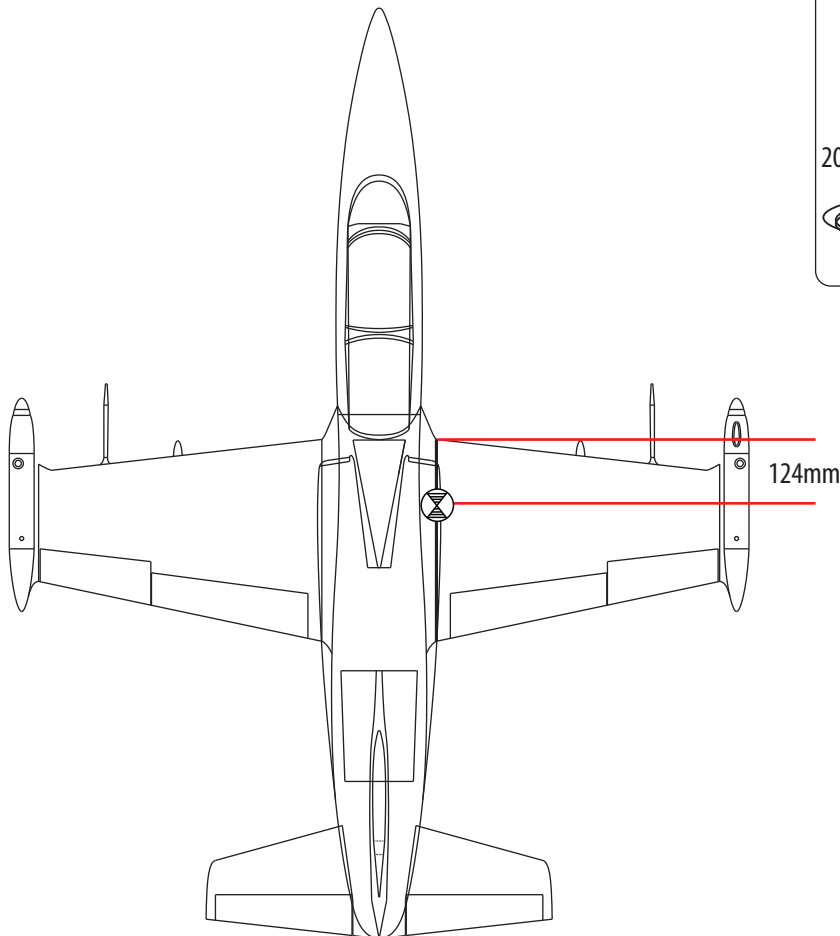

LATERAL BALANCE



After you have balanced a plane on the C.G. You should laterally balance it. Doing this will help the airplane track straighter.

1. Turn the airplane upside down. Attach one loop of heavy string to the engine crankshaft and one to the tail wheel wire. With the wings level, carefully lift the airplane by the string. This may require two people to make it easier.
2. If one side of the wing fall, that side is heavier than the opposite. Add small amounts of lead weight to the bottom side of the lighter wing half's wing tip. Follow this procedure until the wing stays level when you lift the airplane.

6 x 25mm Plastic Screw

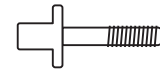

--- 2

Plate of plywood CG

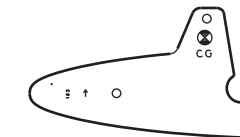

--- 2

2000mm Wire



--- 1

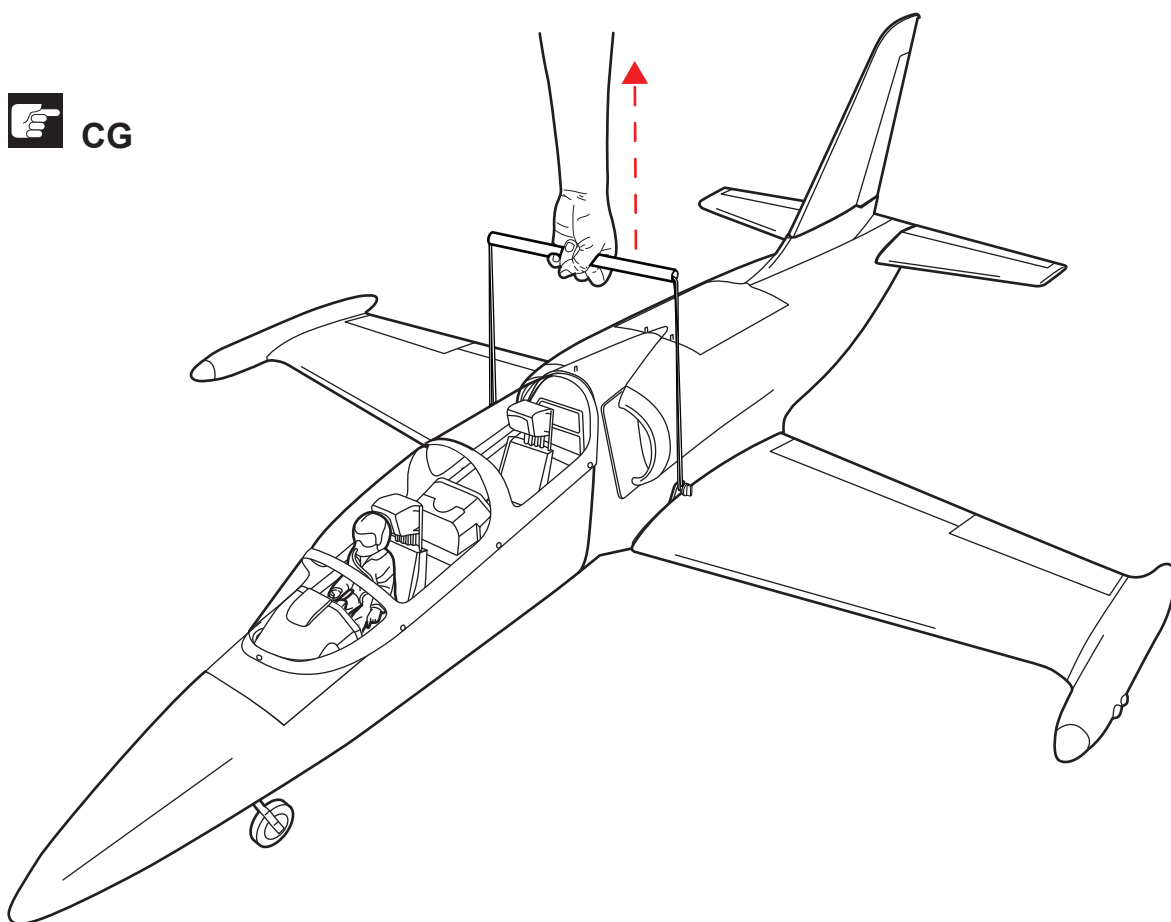
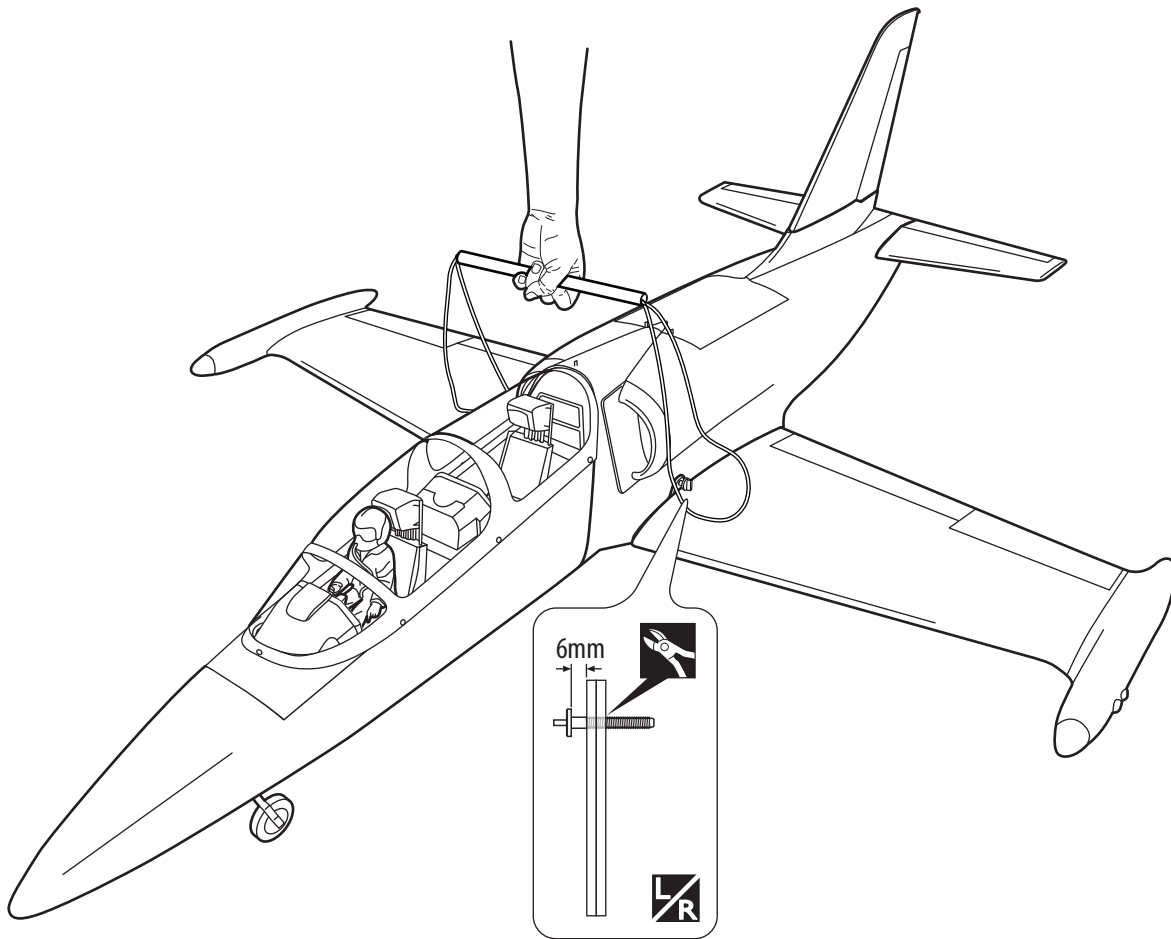

Cut off excess.



Assemble left and right sides the same way.

CONTROL THROWS

1. We highly recommend setting up a plane using the control throws listed.
2. The control throws should be measured at the widest point of each control surface.
3. Check to be sure the control surfaces move in the correct directions.

- **LOW RATE**

Ailerons :	12mm up	12 mm down
Elevator :	10 mm up	10 mm down
Rudder :	35 mm right	35 mm left
Flap :	Mid: 25mm down	

- **HIGH RATE**

Ailerons :	15 mm up	15 mm down
Elevator :	14 mm up	14 mm down
Rudder :	50 mm right	50 mm left
Flap :	Landing: 40mm down	

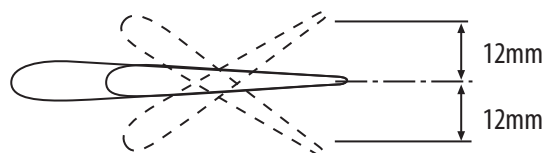

Aileron Control

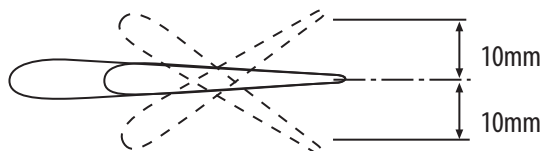

Elevator Control

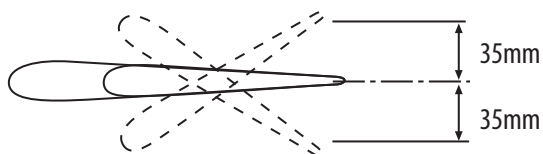

Rudder Control

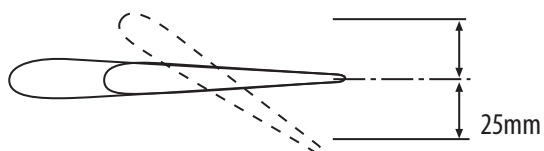

Flap Control

FLIGHT PREPARATION PRE FLIGHT CHECK

1. Completely charge your transmitter and receiver batteries before your first day of flying.
2. Check every bolt and every glue joint in your plane to ensure that everything is tight and well bonded.
3. Double check the balance of the airplane
4. Check the control surface
5. Check the receiver antenna . It should be fully extended and not coiled up inside the fuselage.
6. Properly balance the propeller.

ELECTRIC RETRACT SYSTEM

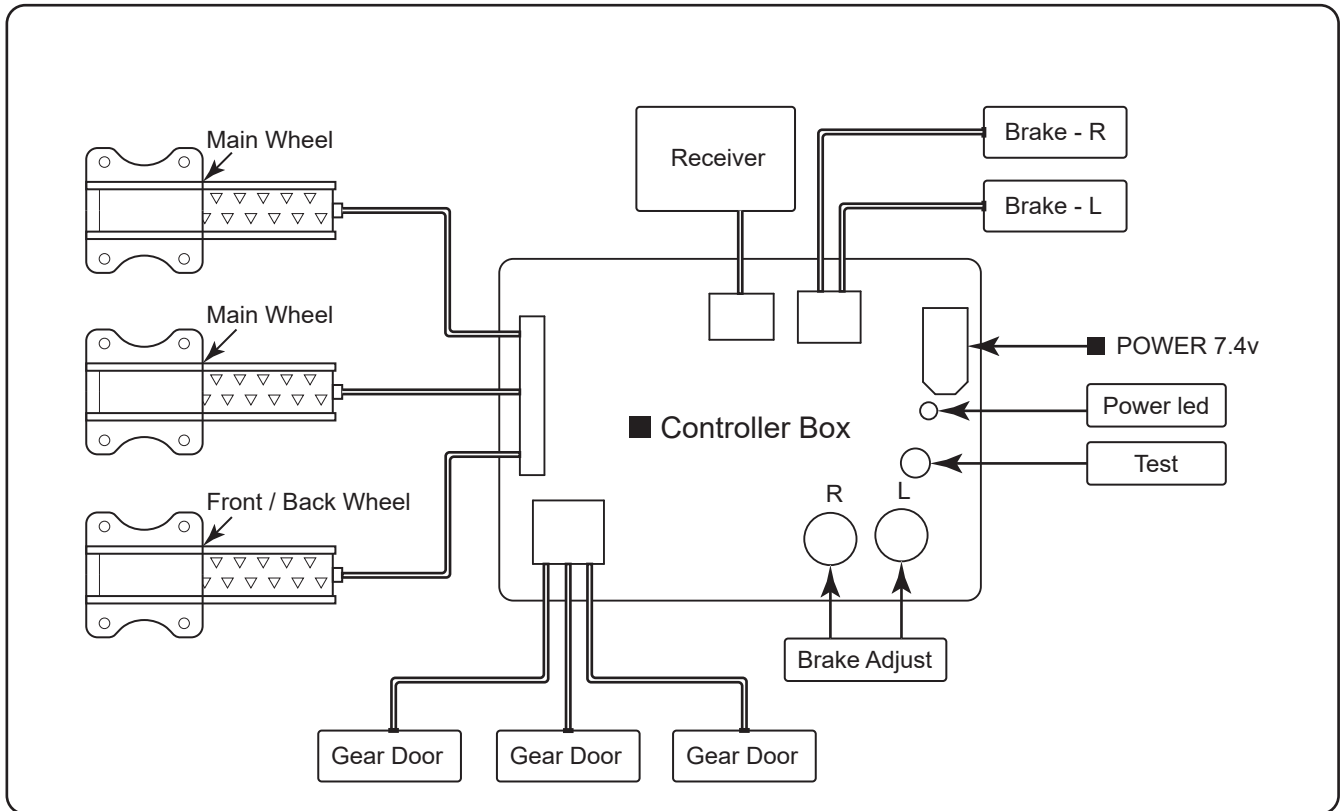

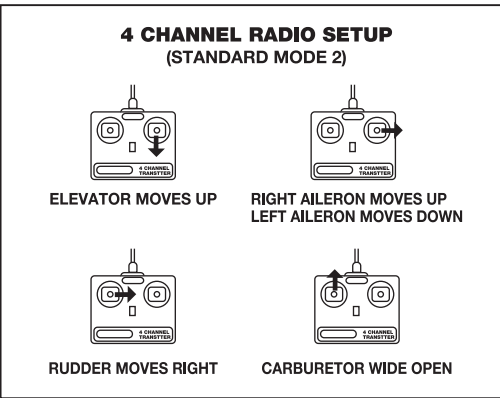

FLIGHT PREPARATION PRE FLIGHT CHECK

1. Completely charge your transmitter and receiver batteries before your first day of flying.
2. Check every bolt and every glue joint in your plane to ensure that everything is tight and well bonded.
3. Double check the balance of the airplane
4. Check the control surface
5. Check the receiver antenna . It should be fully extended and not coiled up inside the fuselage.
6. Properly balance the propeller.

**FOR YOUR RADIO INSTALLATION
BASIC CONNECTION FOR AIRPLANE AND ADJUSTMENT OF SERVOS**

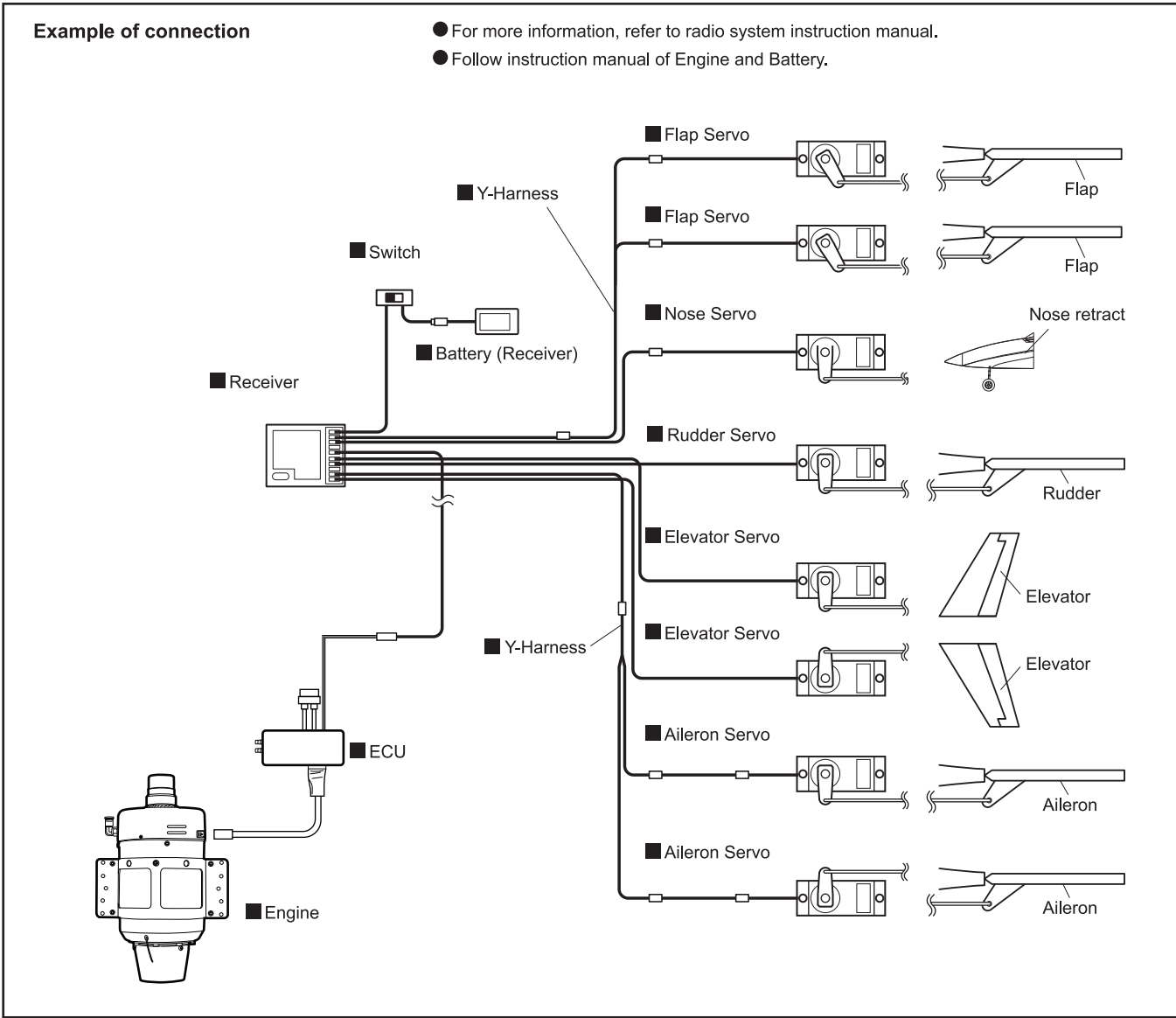

MAIN GEAR DIMENSIONAL DETAIL

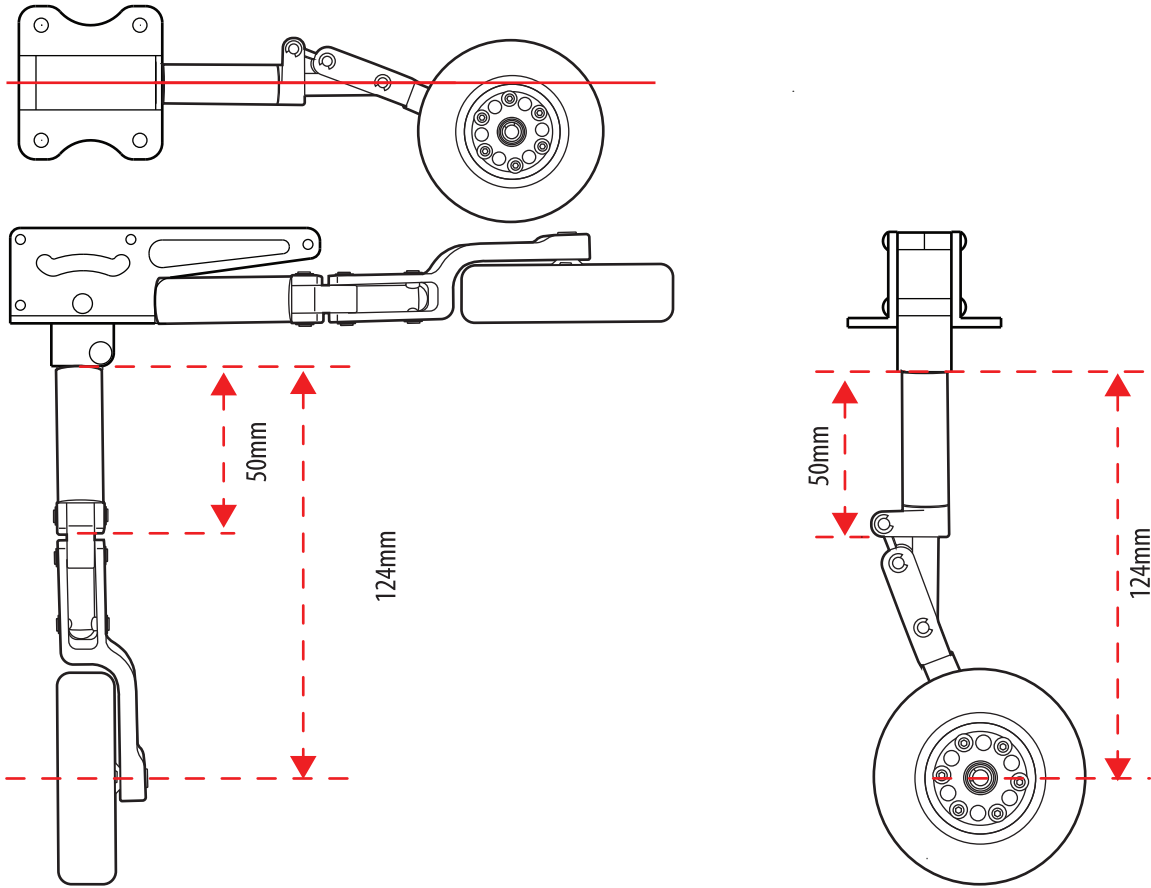

NOSE GEAR DIMENSIONAL DETAIL

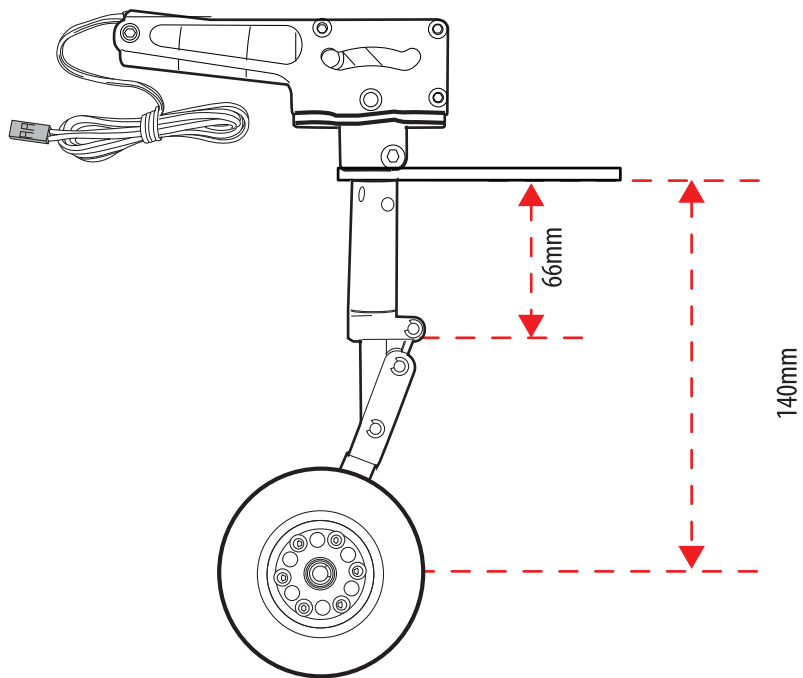

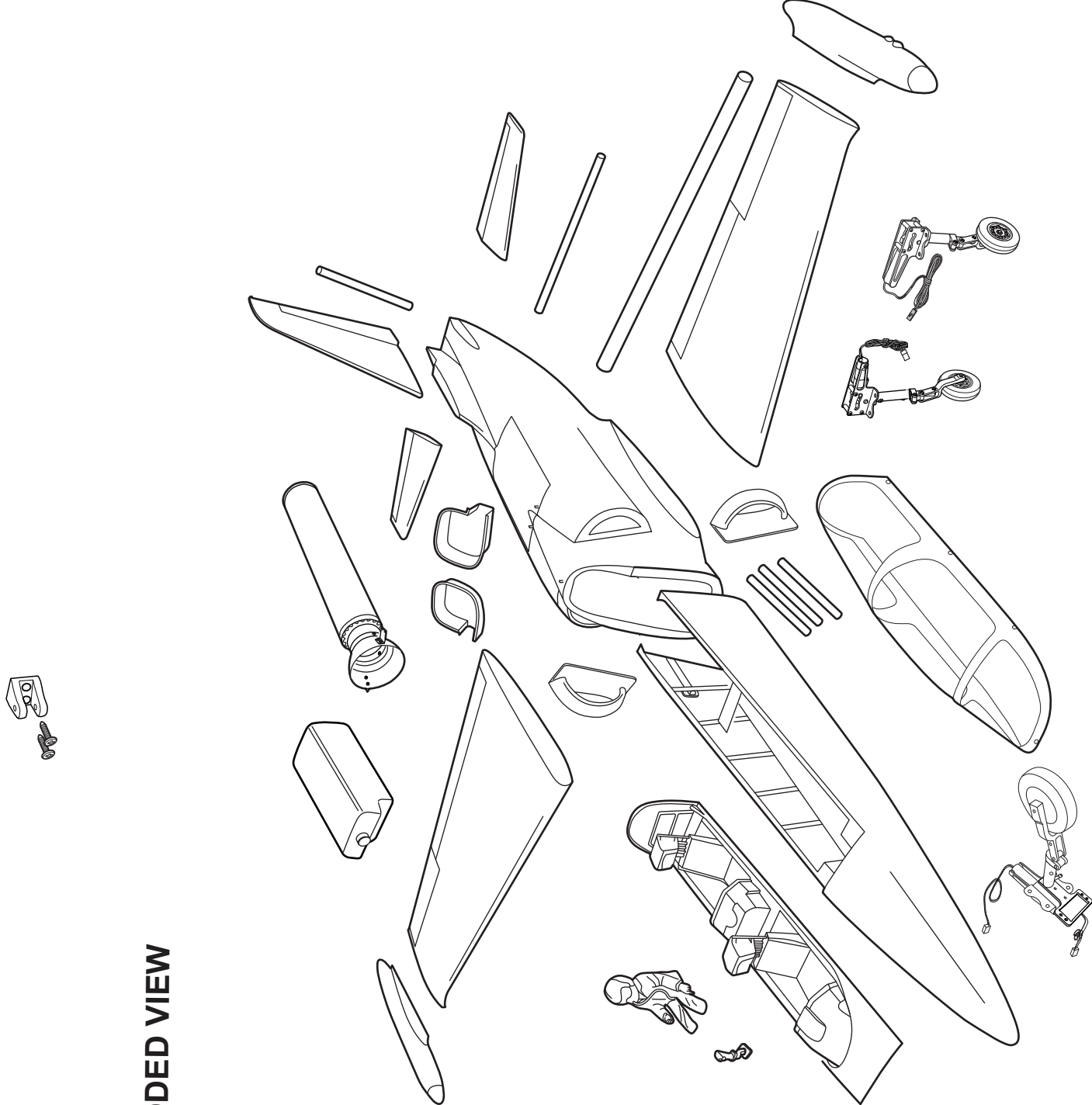

EXPLODED VIEW

DECORATION

Top view

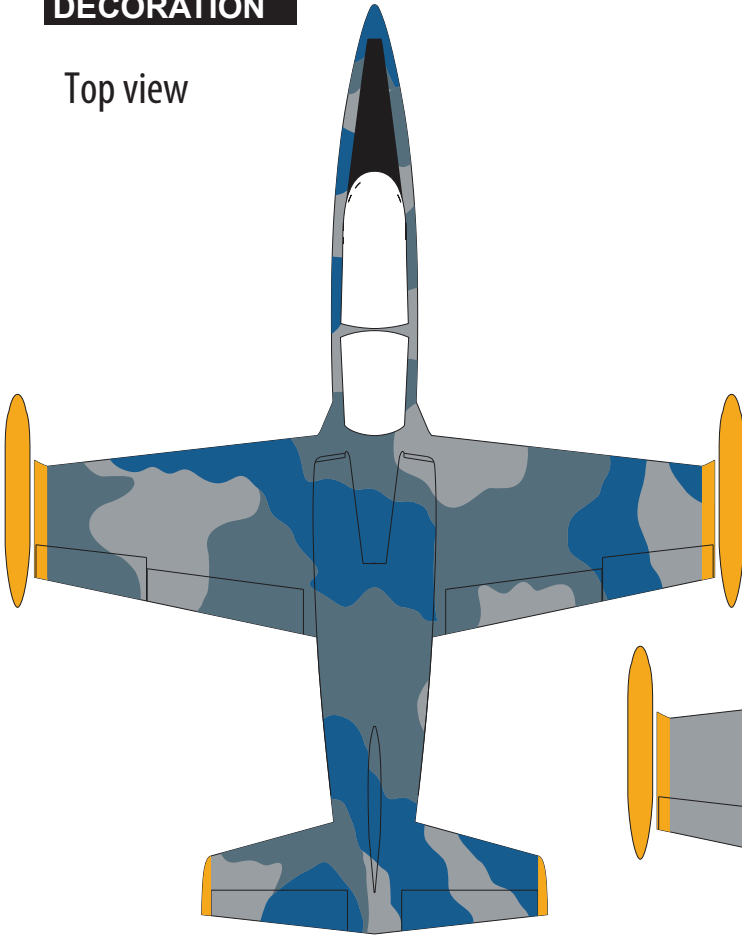

Top view

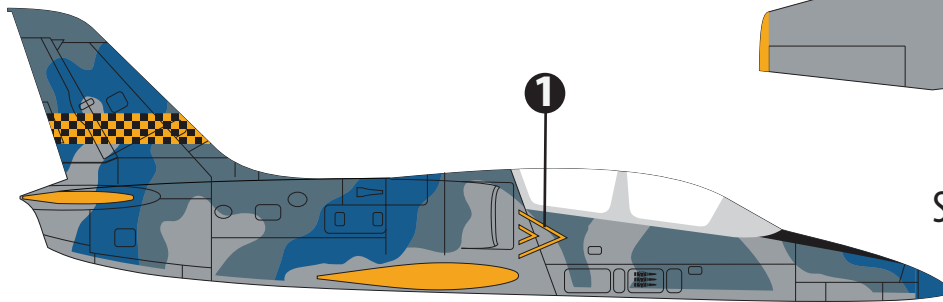
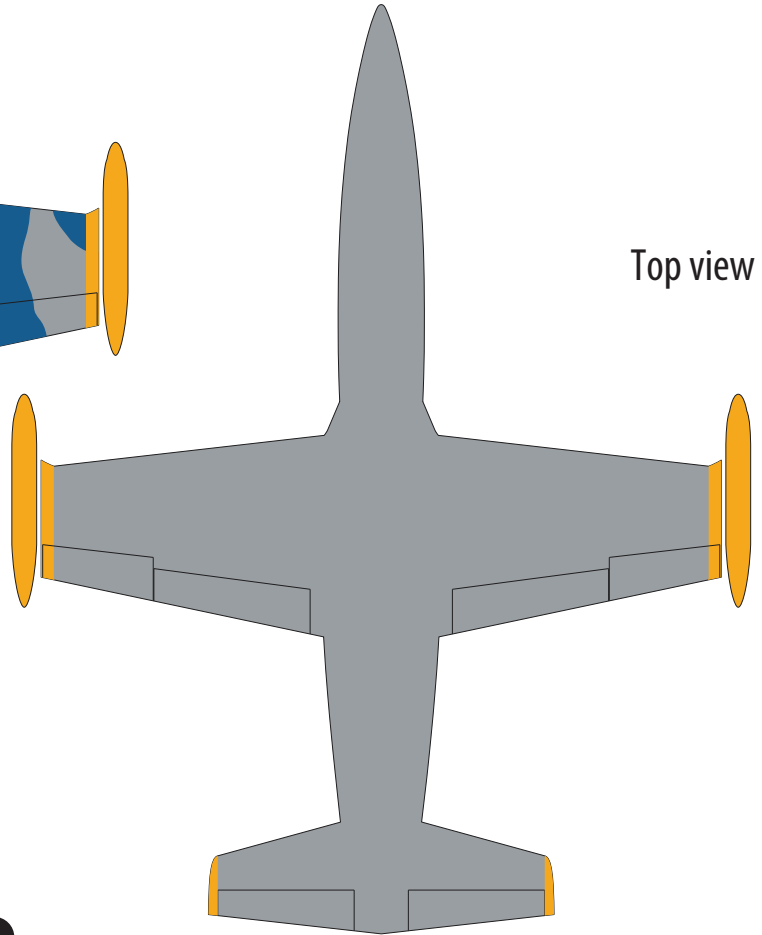

Side view <Right>

Side view <Left>

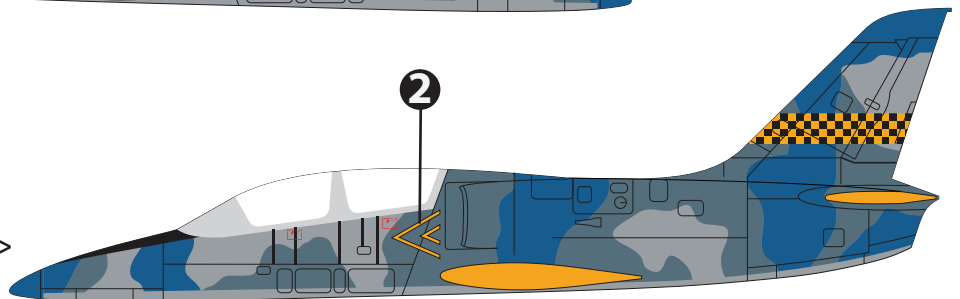

Decal



I/C FLIGHT WARNINGS



Always operate in open areas, away from factories, hospitals, schools, buildings and houses etc. **NEVER** fly your aircraft close to people or built up areas.

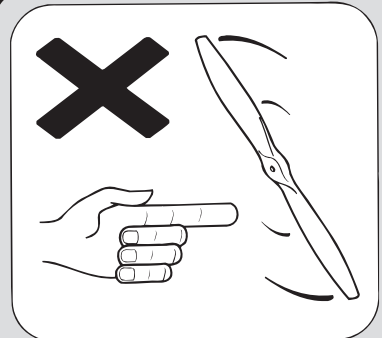

THE PROPELLER IS DANGEROUS
Keep fingers, clothing (ties, shirt sleeves, scarves) or any other loose objects that could be caught or drawn in, away from the propeller. Take care at **ALL** times.

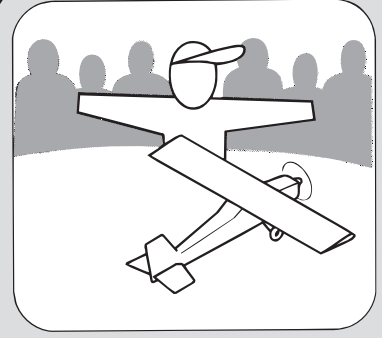

Keep all onlookers (especially small children and animals) well back from the area of operation. This is a flying aircraft, which will cause serious injury in case of impact with a person or animal.



NEVER fly near power lines, aerials or other dangerous areas including airports, motorways etc.



NEVER use damaged or deformed propellers or spinners.

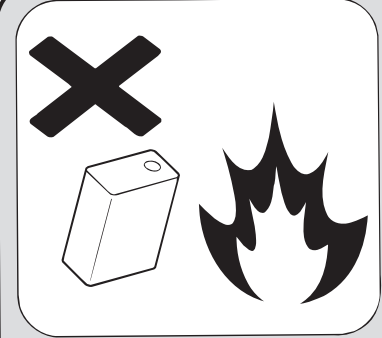

DO NOT dispose of empty fuel containers on a fire, this can lead to an explosion.

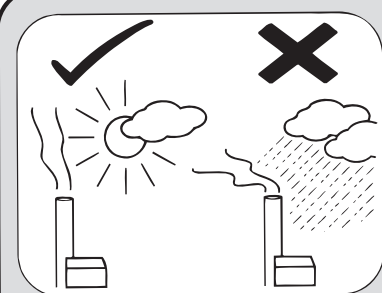

NEVER fly in wet conditions or on windy or stormy days.

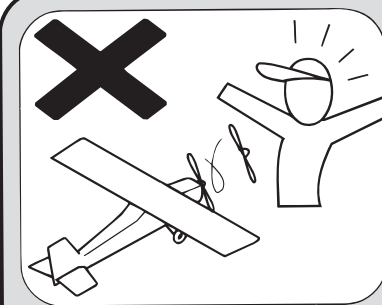

ALWAYS adjust the engine from behind the propeller, and do not allow any part of your body to be in line with the propeller.

I/C FLIGHT GUIDELINES

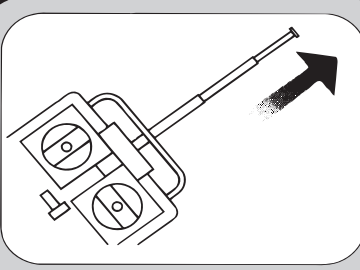

When ready to fly, first extend the transmitter aerial.

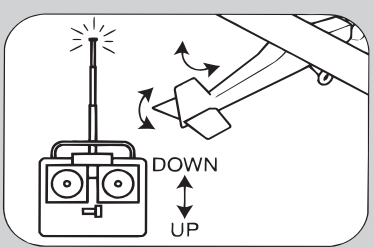

Operate the control sticks on the transmitter and check that the control surfaces move freely and in the CORRECT directions.

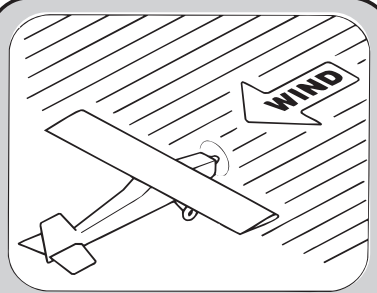

ALWAYS land the model INTO the wind, this ensures that the model lands at the slowest possible speed.

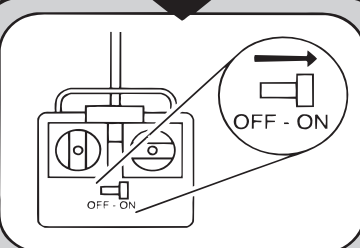

Switch on the transmitter.

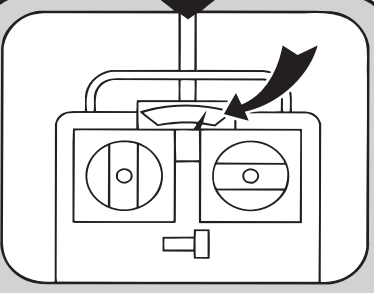

Check that the transmitter batteries have adequate power.

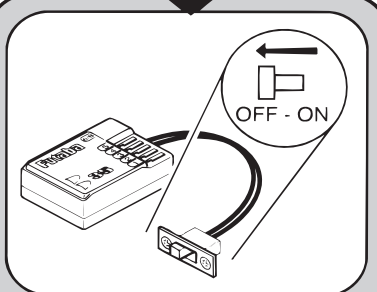

Switch off the receiver.

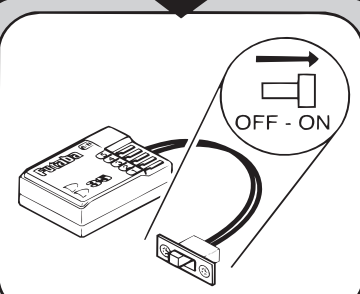

Switch on the receiver.



ALWAYS take off into the wind.

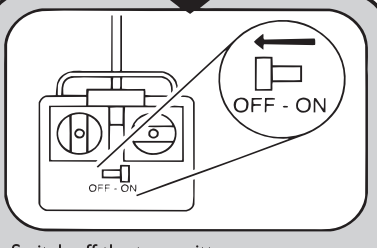

Switch off the transmitter.

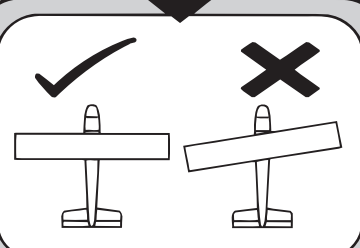

Check that the wings are correctly fitted to the fuselage.

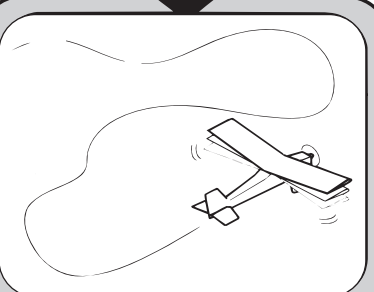

If the model does not respond correctly to the controls, land it as soon as possible and correct the fault.

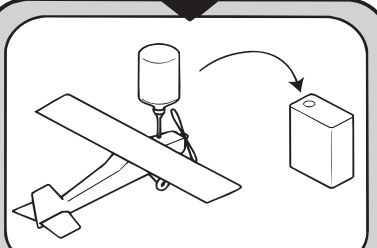

Empty the fuel tank after flying, fuel left in the tank can cause corrosion and lead to engine problems.